

Filter elements, two-stage for installation in wind turbines with Hydac filter housings

Type 65. Filter elements

RE 51461

Edition: 2021-04

Replaces: -



- ▶ Exchangeable with filter element 1300 R ... BN...HC/-B4-KE50
- ▶ Exchangeable with filter element 2600 R ... BN...HC/-B4-KE50
- ▶ Collapse pressure rating up to 15 bar [218 psi]
- ▶ Filter rating 3 ... 10 µm
- ▶ Operating temperature -10 °C ... +100 °C [14 °F ... 212 °F]

Features

- ▶ Low initial pressure differential (ISO 3968)
- ▶ Functional filter element with two filtration stages for wind turbines
- ▶ With integrated bypass valve
- ▶ High dirt holding capacity and filtration performance due to multi-layer glass fiber technology and simultaneously a low initial pressure differential (ISO 3968)
- ▶ Special highly efficient filter materials

Contents

| | |
|---|---------|
| Features | 1 |
| Ordering code | 2 |
| Preferred types | 2 |
| Filter design | 3 |
| Function, set-up | 4 |
| Filter variables | 5 |
| Filter media, technical data | 6 ... 8 |
| Compatibility with hydraulic fluids | 8 |
| Installation, commissioning and maintenance | 9 |
| Directives and standardization | 9 |

Ordering code

of the type 65 filter element.

| | | | | | | | | | |
|------------|----|----|----|----------|-----------|----|-----------|---|----------|
| 01 | 02 | 03 | 04 | 05 | 06 | 07 | | | |
| 65. | | | - | 0 | 00 | - | B4 | - | M |

Filter element

| | | |
|----|--------|------------|
| 01 | Design | 65. |
|----|--------|------------|

Size

| | | |
|----|------------------------------|-------------|
| 02 | according to Hengst standard | 1300 |
| | | 2600 |

Filter rating in µm

| | | | | |
|----|-----------------------|--|---|--------------|
| 03 | Filter element | 1st stage | = main filter, non-woven glass fiber media, absolute (ISO 16889), not cleanable | H3XL |
| | | | | H6XL |
| | | | | PWR10 |
| | 2nd stage | = protective filter, stainless steel wire mesh | G40 | |

Pressure differential

| | | |
|----|---|----------|
| 04 | Maximum admissible pressure differential of the filter element 15 bar [218 psi] | 0 |
|----|---|----------|

Element design

| | | |
|----|-------------------|--------------|
| 05 | Standard adhesive | 0... |
| | Standard material | ... 0 |

Bypass valve

| | | |
|----|----------------|-----------|
| 06 | 4 bar [58 psi] | B4 |
|----|----------------|-----------|

Seal

| | | |
|----|----------|----------|
| 07 | NBR seal | M |
|----|----------|----------|

Order example:**65.1300 PWR10/G40-000-B4-M****Material no.: R928053030****Preferred types****Filter elements**

| Type | Material no. of filter element, filter rating in µm | | |
|--------------------------|---|------------|------------|
| | H3XL | H6XL | PWR10 |
| 65.1300 .../G40-000-B4-M | R928053029 | R928053039 | R928053030 |
| 65.2600 .../G40-000-B4-M | R928053031 | R928053038 | R928053032 |

Filter design

Easy selection of the filter size is made possible by the FilterSelect online tool. The filter can be designed using the operating pressure, flow and fluid system parameters. The required filter rating is based on the application, the sensitivity to contamination of the components and the environmental conditions.

The program leads you through the menu on a step-by-step basis.





A documentation of the filter selection can finally be created in the form of a PDF file. This file contains the entered parameters, the designed filter with material number including spare parts, and the pressure loss curves.

Link FilterSelect:

<http://www.filterselect.de>

Other languages can be selected using the page navigation.

standard search

| | | | | | |
|---|---|--|--|--|--|
| application: | <input type="text" value="hydraulics for industrial use and applications with lubricating oil"/> | | | | |
| Product category: | <input type="text" value="please select"/> | | | | |
| type: | <input type="text" value="please select"/> | | | | |
| pressure range: | <input type="text" value="please select"/> | | | | |
| filter material: | <input type="text" value="please select"/>  | | | | |
| fineness: | <input type="text" value="please select"/> | | | | |
| volume flow rate: | <input type="text"/> [l/min] <input type="text"/> | | | | |
| viscosity: * = working point | <input checked="" type="radio"/> kin viscosity 1: <input type="text" value="32"/> [mm ² /s]  <input type="radio"/> search via type of medium <table border="0" style="margin-left: 20px;"> <tr> <td><input type="text" value="please select"/></td> <td><input type="text" value="full-text search medium"/></td> </tr> <tr> <td><input type="text" value="please select"/></td> <td></td> </tr> </table> temp 1: <input type="text"/> [°C] <input type="text"/> [°F] kin viscosity 1: <input type="text"/> [mm ² /s]  <input type="radio"/> dyn. Viscosity 1: <input type="text"/> [cP] density 1: <input type="text"/> [kg/dm ³] kin viscosity 1: <input type="text"/> [mm ² /s]  | <input type="text" value="please select"/> | <input type="text" value="full-text search medium"/> | <input type="text" value="please select"/> | |
| <input type="text" value="please select"/> | <input type="text" value="full-text search medium"/> | | | | |
| <input type="text" value="please select"/> | | | | | |
| collapse pressure resistance according to ISO 2941: | <input type="text" value="30 bar"/> <input type="text"/> | | | | |
| <input type="button" value="Start search"/>  | | | | | |

Function, set-up

The filter element is the central component of a filter. The actual filtration process takes part in the filter element. The main filter variables, such as retention capacity, dirt holding capacity and pressure loss are determined by the filter elements and the filter media used in them.

Hengst filter elements are used for the filtration of lubricants in wind turbines. The series 65. filter elements consist of two separate filter elements which are flown through one after the other and a bypass valve.

In order to achieve the cleanliness class, the outer filter element made of non-woven glass fiber media (1) serves as the main filter. The inner filter element (2) made of wire mesh serves as a protective filter in case of a cold start.

The outer filter element (1) consists of a multi-layer combination of star-like pleated filter media which are laid around a perforated support tube. The bypass valve (3) is located in the cover of the filter element. The bypass valve has a cracking pressure of 4 bar [58 psi]. The inner filter element (2) is set-up in the same way, except for the filter element mat.

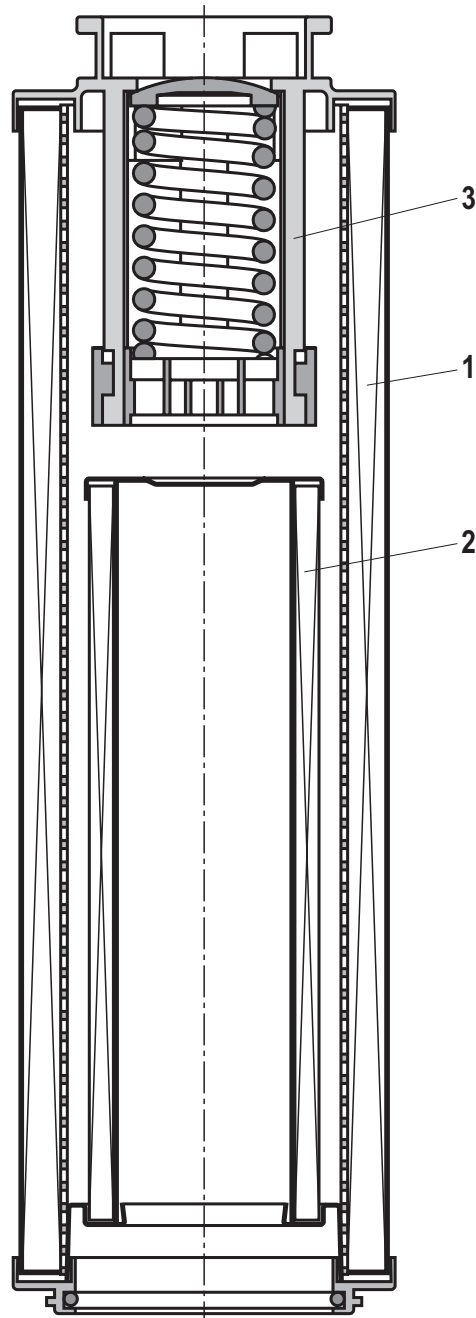

Possible operating conditions:

1. Normal operation with a clean filter element

The fluid flows through the outer filter element (1). The bypass valve is closed. When the fluid flows to the filter outlet, it passes the inner filter element (2).

2. Cold start or highly contaminated outer filter element

Only a very small portion of the fluid flows through the outer filter element (1). Almost the entire flow passes through the bypass valve, which is completely open. Through the open bypass valve, dirt particles get to the clean side of the outer filter element (1). But the inner filter element (2) still retains any coarse particles. Therefore, the downstream components are still protected, even under these conditions.

Filter variables

Filter rating and attainable oil cleanliness

The main goal when using industrial filters is not only the direct protection of machine components but to attain the required oil cleanliness.

Oil cleanliness is defined on the basis of oil cleanliness classes which classify how the amount of particles of the existing contamination is distributed in the operating liquid.

Filtration performance

Filtration ratio $\beta_{x(c)}$ (β value)

The retention capacity of hydraulic filters in a hydraulic system is characterized by the filtration ratio $\beta_{x(c)}$. This variable is therefore the most important performance characteristic of a hydraulic filter. It is measured in the multipass test, and is the average value of the specified

initial and final pressure differential according to ISO 16889 using ISOMTD test dust.

The filtration ratio $\beta_{x(c)}$ is defined as the ratio of the particle count of the respective particle size on both sides of the filter.

Dirt holding capacity

It is also measured using the multipass test and determines the amount of test dust ISOMTD which is fed to the filter medium until a specified pressure differential increase has been reached.

Pressure loss (also pressure differential or delta p)

The pressure loss of the filter element is the relevant characteristic value for the determination of the filter size. The pressure loss with a clean filter element is recommended by the filter manufacturer or defined by the system manufacturer. This characteristic value depends on many factors. Mainly: the rating of the filter medium, its geometry and arrangement in the filter element, the filter area, the operating viscosity of the fluid and the flow. The term "delta p" is often also expressed with the symbol " Δp ".

When dimensioning the filter, an initial pressure loss is determined which must not be exceeded by the new filter element based on the aforementioned conditions.

The following diagram shows the typical pressure loss behavior of filter elements with different filter media at different flows for a viscosity of 30 mm²/s [150 SUS].

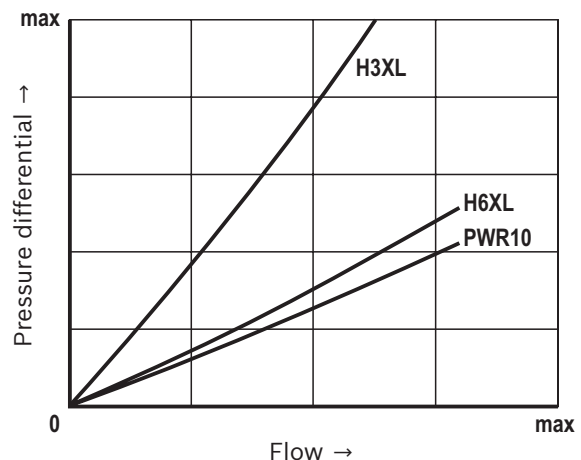

Filter media

Overview

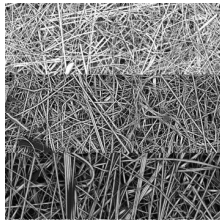
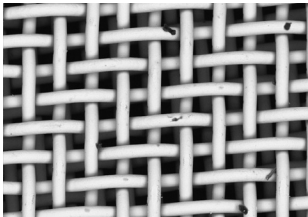
| Filter medium/set-up | Electron microscope image |
|--|---|
| <p>PWR..., non-woven glass fiber media</p> <p>Glass fiber material generation 5 Configuration with a total of 6 layers consisting of 3 filter-efficient glass fiber layers, with electrically conductive non-woven media by default</p> |  |
| <p>G..., stainless steel wire mesh material 1.4401 or 1.4571</p> <p>Surface filter made of stainless steel wire mesh with supporting mesh.</p> |  |

Technical data

(For applications outside these parameters, please consult us!)

| general | | | |
|------------------------------------|-------------------|--|-------------|
| Ambient temperature range | °C [°F] | -40 ... +50 [-40 ... +122] | |
| Weight | NG | 1300 | 2600 |
| | kg [lbs] | 4.2 [9.2] | 9.2 [20.2] |
| Material | ▶ Cover | Polyamide / tin-coated steel | |
| | ▶ Base | Polyamide / tin-coated steel | |
| | ▶ Support tube | Tin-coated steel | |
| | ▶ Filter material | Non-woven glass fiber media / stainless steel wire mesh | |
| | ▶ Bypass valve | Polyamide / steel | |
| | ▶ Seal | NBR | |
| hydraulic | | | |
| Fluid temperature range | °C [°F] | -10 ... +100 [+14 ... +212] (for short periods down to -20 [-4]) | |
| Minimum conductivity of the medium | pS/m | 300 | |
| Filtration direction | | From the outside to the inside | |

Filter media

Technical data

Non-woven glass fiber media, PWR...

If the Hengst PWR... filter medium is professionally designed and applied, it achieves a high degree of cleanliness for lubricants. Due to its defined retention capacity (ISO 16889), it offers highly effective protection for machine and system components which are sensitive to contamination.

- ▶ PWR... depth filter made of inorganic glass fiber material
- ▶ Absolute filtration/defined retention capacity according to ISO 16889
- ▶ High dirt holding capacity due to multi-layer set-up
- ▶ Non-reusable filter (not cleanable due to the depth filtration effect)
- ▶ Attainable oil cleanliness classes according to ISO 4406 up to ISO code 12/8/3 and better

Filter rating and attainable oil cleanliness

| Recommended oil cleanliness according to ISO 4406 (SAE-AS 4059) | Recommended filter medium |
|---|---------------------------|
| ≤ 18/13/10 (5) | H3XL |
| ≤ 19/14/11 (6) | H6XL |
| ≤ 20/16/13 (8) | PWR10 |

Filtration ratio $\beta_{x(c)}$ (β value)

Typical β values of up to 2.2 bar [31.9 psi] Δp pressure increase at the filter element ¹⁾

| Filter medium | Particle size "x" for different β values, measurement according to ISO 16889 | | |
|---------------|--|-------------------------|--------------------------|
| | $\beta_{x(c)} \geq 75$ | $\beta_{x(c)} \geq 200$ | $\beta_{x(c)} \geq 1000$ |
| H3XL | 4.0 $\mu\text{m}(c)$ | < 4.5 $\mu\text{m}(c)$ | 5.0 $\mu\text{m}(c)$ |
| H6XL | 4.8 $\mu\text{m}(c)$ | 5.5 $\mu\text{m}(c)$ | 7.5 $\mu\text{m}(c)$ |
| PWR10 | 7.5 $\mu\text{m}(c)$ | 8.5 $\mu\text{m}(c)$ | 10.5 $\mu\text{m}(c)$ |

¹⁾ Filtration ratio $\beta_{x(c)}$ for other filter media upon request

Filtration ratio $\beta_{x(c)}$ depending on particle size $\mu\text{m}(c)$

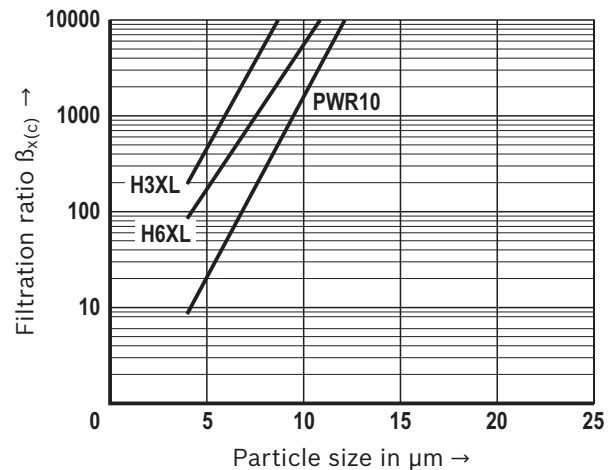

Filter media

Dirt holding capacity according to ISO 16889

Compared to conventional filter media with single layer technology, the PWR... filter material features a high dirt holding capacity because it is made of three separate filter layers connected in series.

Conventional filter element

(single-layer glass fiber material)



Two-layer filter element

(former H...XL material combination)



Hengst PWR... filter element

(three-layer glass fiber material with electrically conductive non-woven media)



Comparison of typical dirt holding capacities of glass fiber filter elements

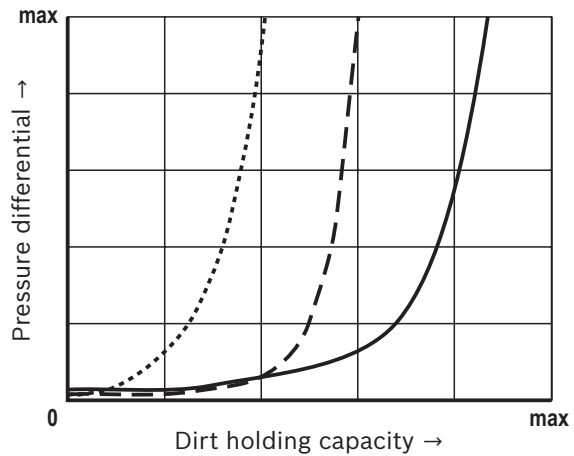

Stainless steel wire mesh, G...

Wire mesh G40

As surface filters, these materials are generally cleanable. Due to their fine mesh, however, cleaning is more difficult than with coarser filter mesh.

Therefore, we recommend cleaning the filters in an ultrasonic bath.

| Filter medium | Design | Mesh size | Attainable oil cleanliness ¹⁾ |
|---------------|------------|------------|--|
| G40 | Woven mesh | 40 µm nom. | no specification possible |

¹⁾ according to ISO 4406 for particles $\geq 4 \mu\text{m}(c)$, $\geq 6 \mu\text{m}(c)$ and $\geq 14 \mu\text{m}(c)$

Compatibility with hydraulic fluids

| Hydraulic fluid | Classification | Suitable sealing materials | Standards |
|-----------------|---|----------------------------|-------------------------|
| Mineral oil | HLP | NBR | DIN 51524 |
| Bio-degradable | ▶ Insoluble in water HETG | NBR | VDMA 24568 |
| Flame-resistant | ▶ Containing water HFAS, HFAE HFC | NBR NBR | DIN 24320 VDMA 24317 |

Important information on hydraulic fluids:

- ▶ For further information and data on the use of other hydraulic fluids refer to data sheet 90220 or contact us!
- ▶ **Flame-resistant - containing water:** due to possible chemical reactions with materials or surface coatings of machine or system components, the service life with these hydraulic fluids may be

less than expected. Filter materials made of filter paper P... (cellulose) may not be used, filter elements with glass fiber filter material (PWR... or wire mesh G) have to be used instead.

- ▶ **Bio-degradable:** If filter materials made of filter paper P... are used instead of PWR..., the filter life may be shorter than expected due to material incompatibility and swelling.

Installation, commissioning and maintenance

When has the filter element to be replaced or cleaned?

As soon as the dynamic pressure or the pressure differential set at the maintenance indicator is reached, the red pushbutton of the mechanical/visual maintenance indicator pops out. If an electronic switching element is provided, an electric signal will moreover sound. In this case, the filter element has to be replaced. Filter elements should be replaced after 6 months at the latest.

Notice:

Depending on the design of the filter size, the maintenance indicator may reach the set dynamic pressure or pressure differential during start-up of the hydraulic system. The electrical signal will go out after the operating temperature has been reached. If the maintenance indicator signal is ignored, the increasing pressure differential may damage the filter element causing it to collapse.

Filter element exchange

- Switch off the system and discharge the filter on the pressure side.
- Also refer to the relevant system maintenance instructions.

WARNING!

Filters are containers under pressure. Before opening the filter housing, check whether the system pressure in the filter has been decreased to ambient pressure. Only then may the filter housing be opened for maintenance. Detailed instructions with regard to the filter element exchange can be found on the relevant data sheet of the filter series manufacturer.

Directives and standardization

Product validation

Hengst filter elements are tested and quality-monitored according to different ISO test standards:

| | |
|---|---------------------|
| Filtration performance test (multipass test) | ISO 16889:2008-06 |
| Δp (pressure loss) characteristic curves | ISO 3968:2001-12 |
| Compatibility with hydraulic fluid | ISO 2943:1998-11 |
| Collapse pressure test | ISO 2941:2009-04 |
| Fluid Technology; Hydraulic Filter – Part 2; Assessment Criteria and Requirements | DIN 24550-2:2006-09 |

The development, manufacture and assembly of Hengst industrial filters and Hengst filter elements is carried out within the framework of a certified quality management system in accordance with ISO 9001:2015.

Notes

Hengst Filtration GmbH
Hardtwaldstr. 43
68775 Ketsch, Germany
Phone +49 (0) 62 02 / 6 03-0
hydraulicfilter@hengst.de
www.hengst.com

© This document, as well as the data, specifications and other information set forth in it, are the exclusive property of Hengst Filtration GmbH. It may not be reproduced or given to third parties without consent of Hengst Filtration GmbH. The data specified above only serve to describe the product. No statements concerning a certain condition or suitability for a certain application can be derived from our information. The information given does not release the user from the obligation of own judgment and verification. It must be remembered that our products are subject to a natural process of wear and aging.