

Axial Piston Variable Pump A10VO

RE 92705/01.12
Replaces: 06.09

1/44

Data sheet

Series 32
Sizes 71 to 180
Nominal pressure 280 bar
Maximum pressure 350 bar
Open circuit



Contents

Type code for standard program	2
Technical data	4
DG – Two-point control, directly operated	8
DR – Pressure control	9
DRG – Pressure control, remotely operated	10
DRF/DRS – Pressure and flow control	11
LA... – Pressure, flow and power control	12
ED – Electro-hydraulic pressure control	13
ER – Electro-hydraulic pressure control	14
Dimensions size 71 to 180	15
Overview of attachments	38
Combination pumps A10VO + A10VO	39
Connector for solenoids	40
Installation instructions	42
General instructions	44

Features

- Variable pump in axial piston swashplate design for hydrostatic drives in an open circuit
- Flow is proportional to the drive speed and displacement.
- The flow can be steplessly varied by adjustment of the swashplate angle.
- Hydrostatic unloading of the cradle bearings
- Port for measurement sensor on high pressure port for size 180 or port plate 22
- Approved for high speeds
- Low noise level
- Increased functional reliability
- Favorable power/weight ratio
- Universal through drive for size 180

Type code for standard program

A10V	O			/	32		-	V					
01	02	03	04		05	06		07	08	09	10	11	12

Axial piston unit

01	Swashplate design, variable, nominal pressure 280 bar, maximum pressure 350 bar	A10V
----	---	-------------

Operation mode

02	Pump, open circuit	O
----	--------------------	----------

Size (NG)

03	Geometric displacement, see table of values on page 6	071	100	140	180
----	---	------------	------------	------------	------------

Control device

		071	100	140	180			
04	Two-point control, directly operated	●	●	●	●	DG		
	Pressure control	●	●	●	●	DR		
		with flow control, hydraulic						
		X-T open	●	●	●	●	DRF	
		X-T closed	●	●	●	●	DRS	
	remotely operated	hydraulic	●	●	●	●	DRG	
	electrical	negative characteristic	U = 12 V	●	●	●	●	ED71
			U = 24 V	●	●	●	●	ED72
		positive characteristic	U = 12 V	●	●	●	●	ER71 ¹⁾
			U = 24 V	●	●	●	●	ER72 ¹⁾
	with flow control, differential pressure control	electrically variable	●	●	●	○	EF ²⁾	
	Power control	with pressure cut-off						
		beginning of control	to 50 bar	●	●	●	●	LA5D
			51 to 90 bar	●	●	●	●	LA6D
91 to 160 bar			●	●	●	●	LA7D	
160 to 240 bar			●	●	●	●	LA8D	
over 240 bar			●	●	●	●	LA9D	
with pressure cut-off, remotely operated								
beginning of control		see above	●	●	●	●	LA.DG	
with pressure cut-off, flow control, X-T closed								
beginning of control		see above	●	●	●	●	LA.DS	
with separate flow control, X-T closed								
beginning of control	see above	●	●	●	●	LA.S		

Series

05	Series 3, Index 2	32
----	-------------------	-----------

Direction of rotation

06	Viewed on drive shaft	clockwise	R
		counter clockwise	L

● = available ○ = on request - = not available

1) The following must be taken into account during project planning:

Excessive current levels ($I > 1200$ mA with 12 V or $I > 600$ mA with 24 V) to the ER solenoid can result in undesired increase of pressure which can lead to pump or system damage:

- Use I_{max} current limiter solenoids.

- A sandwich plate pressure reducing valve can be used to protect the pump in the event of overflow.

An accessory kit with sandwich plate pressure reducing valve can be ordered from Bosch Rexroth under part number R902490825.

2) See RE 92709

Type code for standard program

A10V	O			/	32		-	V					
01	02	03	04		05	06		07	08	09	10	11	12

Seals

07	FKM (fluor-caoutchouc)							●	●	●	●		V
----	------------------------	--	--	--	--	--	--	---	---	---	---	--	---

Drive shaft

		071	100	140	180	
08	Splined shaft ANSI B92.1a	standard shaft	●	●	●	S
		similar to shaft "S" however for higher input torque	●	-	-	R
		reduced diameter, not for through drive	-	●	-	U
		same as shaft "U", but for higher torque; not for through drive	-	●	-	W

Mounting flange

		071	100	140	180	
09	ISO 3019-1 (SAE)	2-hole	●	●	●	C
		4-hole	●	●	●	D

Service line port

		071	100	140	180	
10	SAE flange port at rear, metric fastening thread (not for through drive, N00 only)	●	●	●	●	11
	SAE flange ports on opposite side, metric fastening thread	●	●	●	-	12
	SAE flange ports on opposite side, metric fastening thread with universal through drive	-	-	-	●	22 ¹⁾

Through drive²⁾

		071	100	140	180		
11	Without through drive (only for port plates 11 and 12)	●	●	●	●	N00	
	Universal through drive with through-drive shaft but without coupling, without intermediate flange, plugged with cover in functionally secure manner (with port plate 22 only)	-	-	-	●	U00 ¹⁾	
	Flange ISO 3019-1 Diameter	coupling for splined shaft ²⁾ diameter					
	82-2 (A)	5/8 in 9T 16/32DP	●	●	●	-	K01
		3/4 in 11T 16/32DP	●	●	●	-	K52
	101-2 (B)	7/8 in 13T 16/32DP	●	●	●	-	K68
		1 in 15T 16/32DP	●	●	●	-	K04
	127-2 (C)	1 1/4 in 14T 12/24DP	●	●	●	-	K07
		1 1/2 in 17T 12/24DP	-	●	●	-	K24
	127-4 (C)	1 1/4 in 14T 12/24DP	○	●	●	-	K15
	152-4 (D)	1 3/4 in 13T 8/16DP	-	-	●	-	K17
	82-2 (A)	5/8 in 9T 16/32DP	-	-	-	●	U01
		3/4 in 11T 16/32DP	-	-	-	●	U52
	101-2 (B)	7/8 in 13T 16/32DP	-	-	-	●	U68
		1 in 15T 16/32DP	-	-	-	●	U04
	127-2 (C)	1 1/4 in 14T 12/24DP	-	-	-	○	U07
		1 1/2 in 17T 12/24DP	-	-	-	●	U24
	127-4 (C)	1 1/4 in 14T 12/24DP	-	-	-	●	U15
	152-4 (D)	1 3/4 in 13T 8/16DP	-	-	-	●	U17

Connectors for solenoids³⁾

		071	100	140	180	
12	Without	●	●	●	●	0
	DEUTSCH - molded connector, 2-pin – without suppressor diode	●	●	●	●	P

● = available ○ = on request - = not available

1) See RE 95581 universal through drive

2) Coupling for splined shaft according to ANSI B92.1a-1976 (drive shaft allocation according to SAE J744)

3) Connectors for other electric components may deviate.

Technical data

Hydraulic fluid

Before starting project planning, please refer to our data sheets RE 90220 (mineral oil) and RE 90221 (environmentally acceptable hydraulic fluids) and RE 90222 (HFD hydraulic fluids) for detailed information regarding the choice of hydraulic fluid and application conditions.

When using environmentally acceptable hydraulic fluids, the limitations regarding technical data and seals must be observed; please contact us. When ordering, indicate the hydraulic fluid that is to be used.

Operating viscosity range

For optimum efficiency and service life we recommend that the operating viscosity (at operating temperature) be selected in the range

$$v_{\text{opt}} = \text{optimum operating viscosity } 16 \dots 36 \text{ mm}^2/\text{s}$$

referred to reservoir temperature (open circuit).

Limits of viscosity range

For critical operating conditions the following values apply:

$$v_{\text{min}} = 10 \text{ mm}^2/\text{s}$$

short-term ($t \leq 1 \text{ min}$)
at max. case drain temperature of 115 °C.

Please also ensure that the max. case drain temperature of 115 °C is not exceeded in localized areas (for instance, in the bearing area). The fluid temperature in the bearing area is approx. 5 K higher than the average case drain temperature.

$$v_{\text{max}} = 1600 \text{ mm}^2/\text{s}$$

short-term ($t \leq 1 \text{ min}$)
on cold start
($p \leq 30 \text{ bar}$, $n \leq 1000 \text{ rpm}$, $t_{\text{min}} -40 \text{ °C}$)

Depending on the installation situation, special measures are necessary at temperatures between -40 °C and -25 °C. Please contact us.

For detailed information on operation with low temperatures see data sheet RE 90300-03-B.

Selection diagram

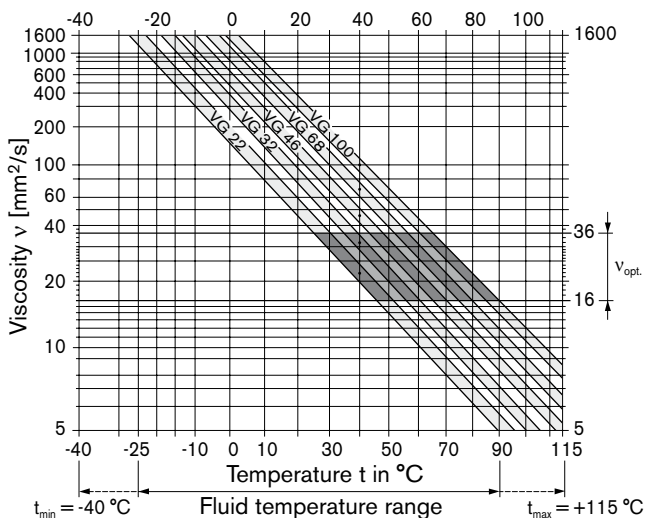

Notes on the choice of hydraulic fluid

In order to select the correct hydraulic fluid, it is necessary to know the operating temperature in the reservoir (open circuit) in relation to the ambient temperature.

The hydraulic fluid should be selected so that within the operating temperature range, the viscosity lies within the optimum range (v_{opt} , see shaded section of the selection diagram). We recommend to select the higher viscosity grade in each case.

Example: at an ambient temperature of X °C the operating temperature is 60 °C. In the optimum viscosity range (v_{opt} ; shaded area) this corresponds to viscosity grades VG 46 and VG 68; VG 68 should be selected.

Important:

The case drain temperature is influenced by pressure and speed and is always higher than the reservoir temperature. However, at no point in the component may the temperature exceed 115 °C.

If the above conditions cannot be met, due to extreme operating parameters please contact us.

Filtration of the hydraulic fluid

The finer the filtration the better the cleanliness level of the hydraulic fluid and the longer the service life of the axial piston unit.

In order to guarantee the functional reliability of the axial piston unit it is necessary to carry out a gravimetric evaluation of the hydraulic fluid to determine the particle contamination and the cleanliness level according to ISO 4406. A cleanliness level of at least is necessary 20/18/15.

At very high fluid temperatures (90 °C to max. 115 °C) a cleanliness level of at least 19/17/14 according to ISO 4406 is necessary.

If the above cleanliness levels cannot be maintained, please contact us.

Technical data

Operating pressure range

(when using mineral oil)

Pressure at service line port B

Nominal pressure p_{nom} _____ 280 bar absolute

Maximum pressure p_{max} _____ 350 bar absolute

Single operating period _____ 2.0 ms

Total operating period _____ 300 h

Minimum pressure (high-pressure side) _____ 10 bar absolute¹⁾

Rate of pressure change $R_{A\ max}$ _____ 16000 bar/s

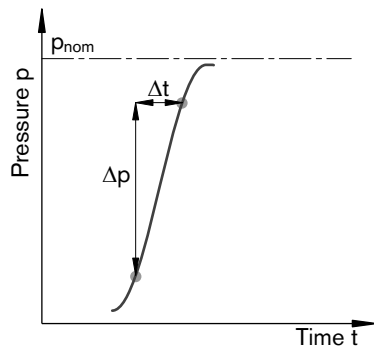

Pressure at suction port S (inlet)

Sizes 71 to 100 at 1800 rpm

Minimum pressure $p_{S\ min}$ _____ 0.8 bar absolute

Sizes 140 to 180 at 1800 rpm

Minimum pressure $p_{S\ min}$ _____ 1 bar absolute

Maximum pressure $p_{S\ max}$ _____ 10 bar¹⁾ absolute

Case drain pressure

Maximum permissible pressure of the case drain (at port L, L₁): maximum 0.5 bar higher than inlet pressure at port S, but not higher than 2 bar absolute.

$p_{L\ max\ abs}$ _____ 2 bar absolute¹⁾

Definition

Nominal pressure p_{nom}

The nominal pressure corresponds to the maximum design pressure.

Maximum pressure p_{max}

The maximum pressure corresponds to the maximum operating pressure within the single operating period. The total of the single operating periods must not exceed the total operating period.

Minimum pressure (high-pressure side)

Minimum pressure in the high-pressure side (port B) that is required in order to prevent damage to the axial piston unit.

Minimum pressure (inlet)

Minimum pressure at suction port S (inlet) that is required to prevent damage to the axial piston unit. The minimum pressure depends on the speed and displacement of the axial piston unit.

Rate of pressure change R_A

Maximum permissible pressure build-up and pressure reduction speed with a pressure change over the entire pressure range.

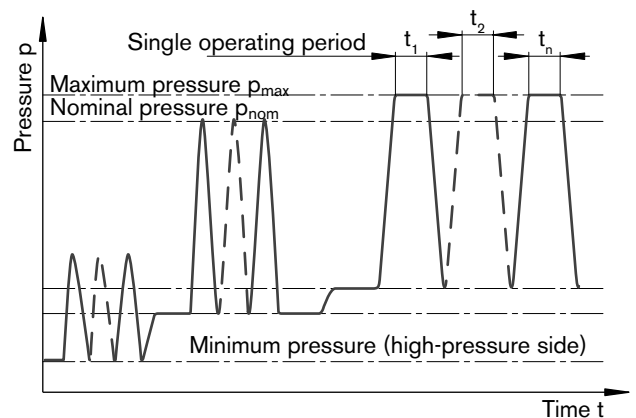

Total operating period = $t_1 + t_2 + \dots + t_n$

¹⁾ Other values on request

Technical data

Table of values (theoretical values, without efficiencies and tolerances: values rounded)

Size	NG		71	100	140	180	
Displacement, geometric (per revolution)	$V_{g \max}$	cm ³	71.1	100	140	180	
Maximum speed ¹⁾ at $V_{g \max}$	n_{nom}	rpm	2550	2300	2200	1800	
Flow at n_{nom} and $V_{g \max}$	$q_{v \max}$	l/min	181	230	308	324	
Power at $\Delta p = 280$ bar at n_{nom} and $V_{g \max}$	P_{\max}	kW	85	107	144	151	
Torque ¹⁾ at $V_{g \max}$ and	$\Delta p = 280$ bar	T_{\max}	Nm	317	446	624	802
	$\Delta p = 100$ bar	T	Nm	113	159	223	286
Rotary stiffness drive shaft	S	c	Nm/rad	71884	121142	169537	171107
	R	c	Nm/rad	76545	–	–	–
	U	c	Nm/rad	–	91093	–	–
	W	c	Nm/rad	–	101847	–	–
Moment of inertial rotary group	J_{TW}	kgm ²	0.0087	0.0167	0.0242	0.033	
Filling capacity	V	L	1.6	2.2	3.0	2.7	
Mass (12N00 without through drive) approx.	m	kg	36.5	55	70	–	
Mass (12Kxx) approx.	m	kg	47	69	73	–	
Mass (22Uxx) approx.	m	kg	–	–	–	78	

- 1) The values apply
- for an absolute pressure $p_{\text{abs}} = 1$ bar at suction port S
 - within the optimum viscosity range from $v_{\text{opt}} = 16$ to 36 mm²/s
 - for mineral-oil based hydraulic fluids.

Note

Exceeding the maximum or falling below the minimum permissible values can lead to a loss of function, a reduction in operational service life or total destruction of the axial piston unit. We recommend to check the loading through tests or calculation / simulation and comparison with the permissible values.

Calculation of characteristics

Flow	$q_v = \frac{V_g \cdot n \cdot \eta_v}{1000}$	[l/min]	V_g = Displacement per revolution in cm ³
			Δp = Differential pressure in bar
Torque	$T = \frac{V_g \cdot \Delta p}{20 \cdot p \cdot \eta_{mh}}$	[Nm]	n = Speed in rpm
			η_v = Volumetric efficiency
Power	$P = \frac{2\pi \cdot T \cdot n}{60000} = \frac{q_v \cdot \Delta p}{600 \cdot \eta_t}$	[kW]	η_{mh} = Mechanical-hydraulic efficiency
			η_t = Total efficiency ($\eta_t = \eta_v \cdot \eta_{mh}$)

Technical data

Permissible radial and axial loading on the drive shaft

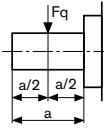
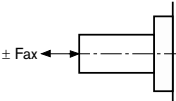
Size	NG	71	100	140	180
Radial force maximum at $a/2$	 $F_{q \max}$ N	960	2300	2800	2800
Axial force maximum	 $\pm F_{ax \max}$ N	400	1560	1600	1300

Permissible input and through-drive torques

Size	NG	71	100	140	180
Torque at $V_{g \max}$ and $\Delta p = 280 \text{ bar}^1$	T_{\max} Nm	317	446	624	
Input torque for drive shaft, maximum ²⁾					
S	$T_{E \max}$ Nm in	626 1 1/4	1104 1 1/2	1620 1 3/4	1620 1 3/4
R	$T_{E \max}$ Nm in	644 1 1/4	–	–	–
U	$T_{E \max}$ Nm in	–	595 1 1/4	–	–
W	$T_{E \max}$ Nm in	–	636 1 1/4	–	–
Through-drive torque for drive shaft, maximum					
S	$T_{D \max}$ Nm	492	778	1266	1266
R	$T_{D \max}$ Nm	548	–	–	–

1) Without considering efficiency

2) For drive shafts free of radial force

Distribution of torques

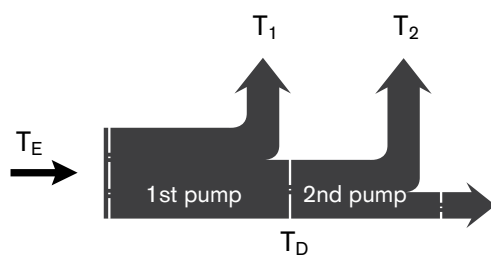

DG – Two-point control, directly operated

The variable pump can be set to a minimum swivel angle by connecting an external control pressure to port X.

This will supply control fluid directly to the stroke piston; a minimum control pressure of $p_{st} \geq 50$ bar is required.

The variable pump can only be switched between $V_{g \max}$ and $V_{g \min}$.

Please note, that the required control pressure at port X is directly dependent on the actual operating pressure p_B in port B. (See control pressure characteristic).

Control pressure p_{st} in X = 0 bar $\cong V_{g \max}$

Control pressure p_{st} in X ≥ 50 bar $\cong V_{g \min}$

Control pressure characteristic

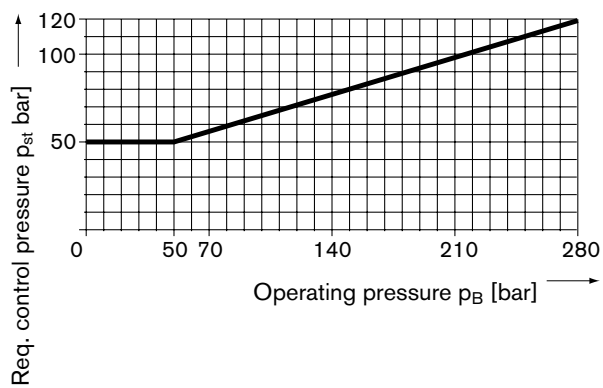

Circuit diagram

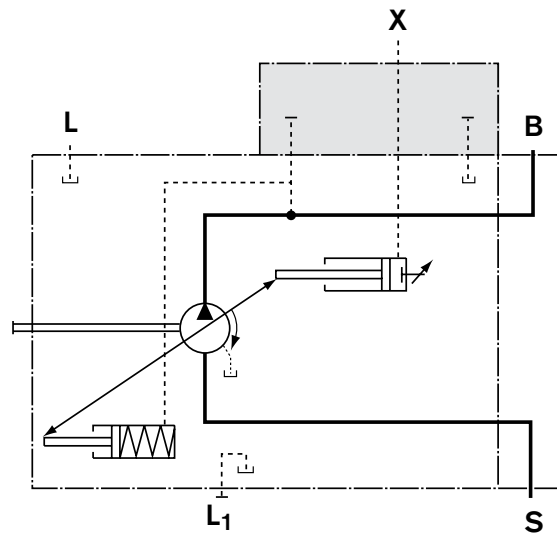

	Port for
B	Service line
S	Suction line
L, L ₁	Case drain (L ₁ plugged)
X	Pilot pressure
M _B	Measuring operating pressure

DR – Pressure control

The pressure control limits the maximum pressure at the pump output within the pump control range. The variable pump only supplies as much hydraulic fluid as is required by the consumers. If the operating pressure exceeds the target pressure set at the pressure valve, the pump will regulate towards a smaller displacement. The pressure can be set steplessly at the control valve.

Static characteristic

(at $n_1 = 1500 \text{ rpm}$; $t_{\text{fluid}} = 50 \text{ }^\circ\text{C}$)

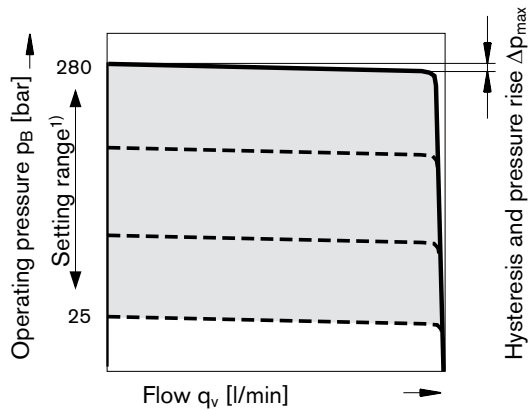

- 1) In order to prevent damage to the pump and the system, this setting range is the permissible setting range and must not be exceeded. The range of possible settings at the valve are greater.

Circuit diagram

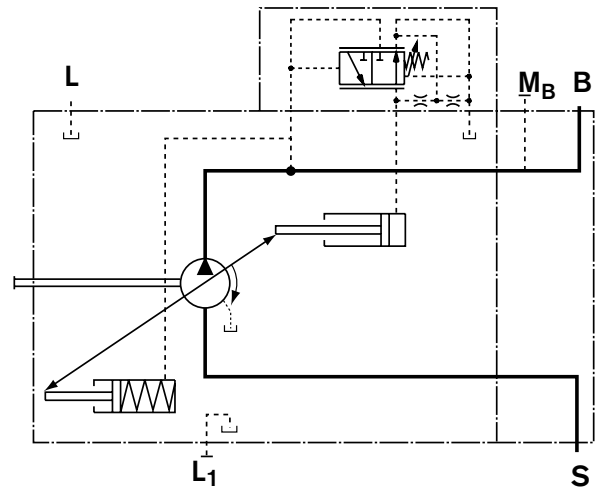

	Port for
B	Service line
S	Suction line
L, L ₁	Case drain (L ₁ plugged)
M _B	Measuring operating pressure

Control data

Hysteresis and repeatability Δp _____ maximum 3 bar

Pressure rise, maximum

NG	71	100	140	180
Δp bar	8	10	12	14

Control fluid consumption _____ maximum approx. 3 l/min

DRG – Pressure control, remotely operated

The DR-control valve (see page 9) is overriding this DRG-remote setting of max. outlet pressure.

A pressure relief valve can be externally piped to port X for remote setting of pressure below the setting of the DR control valve spool. This relief valve is not included in the delivery contents of the DRG control.

The differential pressure at the DRG control valve is set as standard to 20 bar. This results in a pilot oil flow to the relief valve of approx. 1.5 l/min at port X. If another setting is required (range from 10-22 bar) please state in clear text.

As a separate pressure relief valve we can recommend:

DBDH 6 (hydraulic) to RE 25402 or

DBETR-SO 381 with orifice \varnothing 0.8 mm in P (electric) to RE 29166.

The max. length of piping should not exceed 2 m.

Static characteristic

(at $n_1 = 1500$ rpm; $t_{fluid} = 50$ °C)

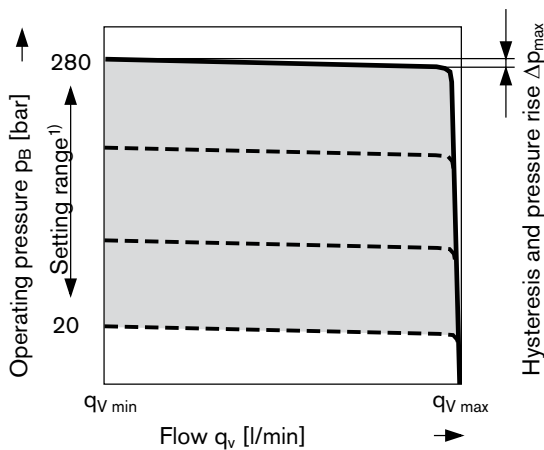

- 1) In order to prevent damage to the pump and the system, this setting range is the permissible setting range and must not be exceeded. The range of possible settings at the valve are greater.

Circuit diagram

Not included in the delivery contents

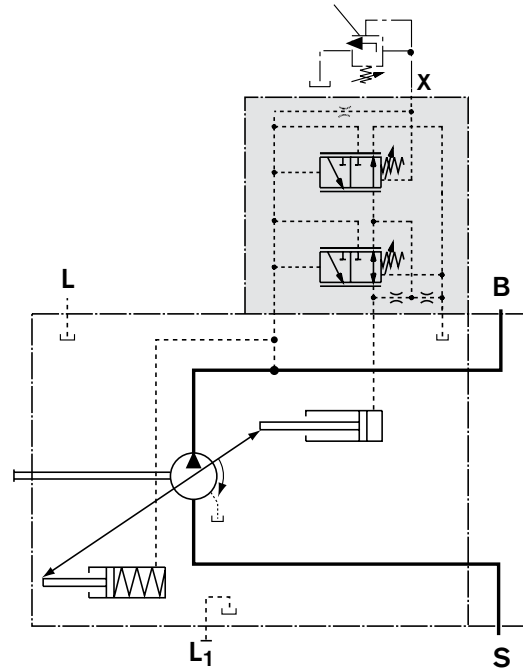

	Port for
B	Service line
S	Suction line
L, L₁	Case drain (L ₁ plugged)
X	Pilot pressure
M_B	Measuring operating pressure

Control data

Hysteresis and repeatability Δp _____ maximum 3 bar

Pressure rise, maximum

NG	71	100	140	180
Δp bar	8	10	12	14

Control fluid consumption _____ maximum approx. 4.5 l/min

DRF/DRS – Pressure and flow control

In addition to the pressure control function (see page 9), the pump flow may be varied by means of a differential pressure over an adjustable orifice (e.g. directional valve) installed in the service line to the actuator. The pump flow is equal to the actual required flow by the actuator, regardless of changing pressure levels.

The pressure control overrides the flow control.

Note

The DRS-valve version has no connection between X and the reservoir (pump housing).
 Unloading the LS-pilot line must be possible in the valve system.
 Because of the flushing function sufficient unloading of the X-line must also be provided.

Static characteristic

Flow control at $n_1 = 1500 \text{ rpm}$; $t_{\text{fluid}} = 50 \text{ }^\circ\text{C}$

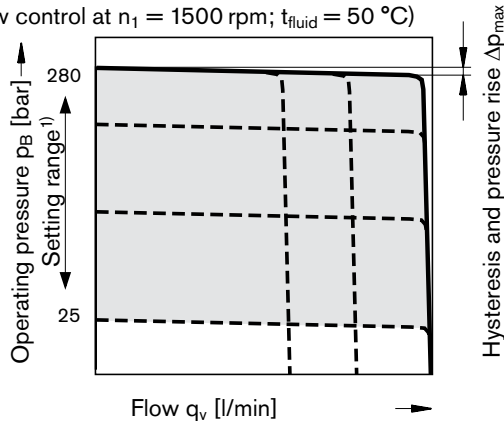

- 1) In order to prevent damage to the pump and the system, this setting range is the permissible setting range and must not be exceeded.
 The range of possible settings at the valve are greater.

Static characteristic at variable speed

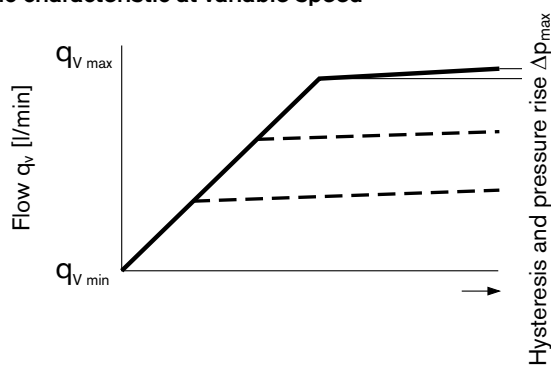

Circuit diagram

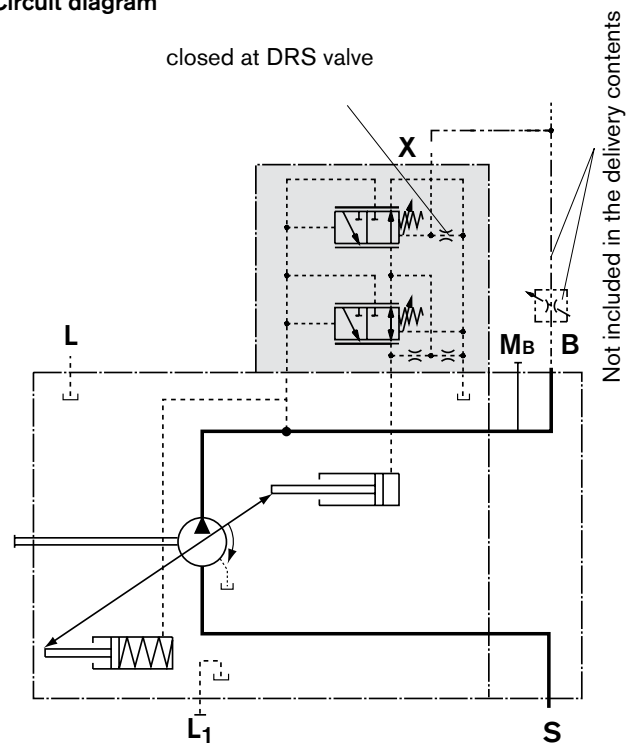

	Port for
B	Service line
S	Suction line
L, L ₁	Case drain (L ₁ plugged)
X	Pilot pressure
M _B	Measuring operating pressure

Differential pressure Δp :

Standard setting: 14 to 22 bar.
 If another setting is required, please state in clear text.
 Unloading port X to reservoir results in a zero stroke (standby) pressure which lies about 1 to 2 bar higher than the defined differential pressure Δp . System influences are not taken into account.

Control data

Data for pressure control DR, see page 9.
 Maximum flow deviation measured with drive speed $n = 1500 \text{ rpm}$.

NG	71	100	140	180
$\Delta q_{v \text{ max}}$ l/min	2.8	4.0	6.0	8.0

Control fluid consumption DRF maximum approx. 3 to 4.5 l/min
 Control fluid consumption DRS maximum ____ approx. 3 l/min

LA... – Pressure, flow and power control

Execution of the pressure control like DR(G), see pages 9/10.
Execution of the pressure and flow control like DRS, see pages 11.

In order to achieve a constant drive torque with varying operating pressures, the swivel angle and with it the output flow from the axial piston pump is varied so that the product of flow and pressure remains constant.

Flow control is possible below the power control curve.

The power characteristic is set in the factory; when ordering, please state in clear text, e.g. 20 kW at 1500 rpm.

Control data

For technical data of pressure control DR see page 9.

For technical data of flow control FR see page 11.

Beginning of control:

Control fluid consumption max. approx. 5.5 l/min

Beginning of control	Torque T [Nm] for size				Order code
	71	100	140	180	
to 50 bar	to 67.0	to 94.0	to 132.0	to 167.0	LA5
51 to 90 bar	67.1 - 121.0	94.1 - 169.0	132.1 - 237.0	167.1 - 302.0	LA6
91 to 160 bar	121.1 - 213.0	169.1 - 299.0	237.1 - 418.0	302.1 - 540.0	LA7
161 to 240 bar	213.1 - 319.0	299.1 - 449.0	418.1 - 629.0	540.1 - 810.0	LA8
over 240 bar	over 319.1	over 449.1	over 629.1	over 810.1	LA9

Conversion of the torque values in power [kW] :

$$P = \frac{T}{6.4} \text{ [kW] (at 1500 rpm)}$$

or

$$P = \frac{2\pi \cdot T \cdot n}{60000} \text{ [kW] (for speeds, see table on page 6)}$$

Static curves and torque characteristic

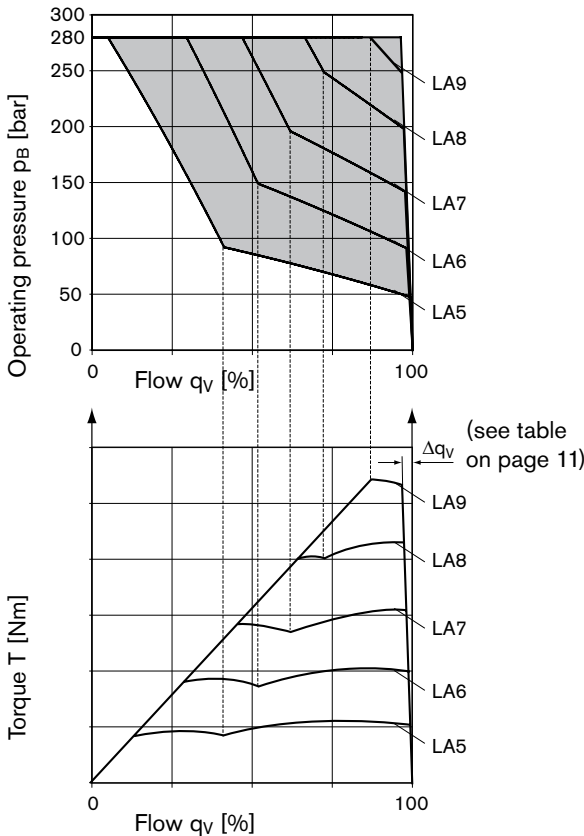

Circuit diagram (LAXD) with pressure cut-off

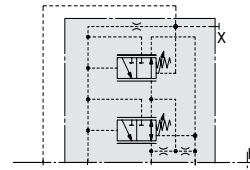

Circuit diagram (LAXDG) with pressure cut-off, remotely operated

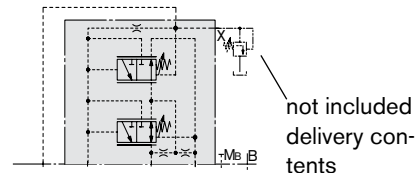

Circuit diagram (LAXS) with separate flow control

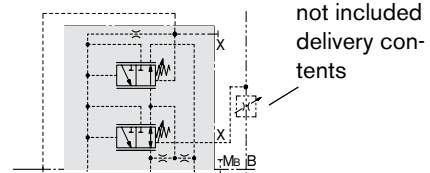

Circuit diagram (LAXDS) with pressure and flow control

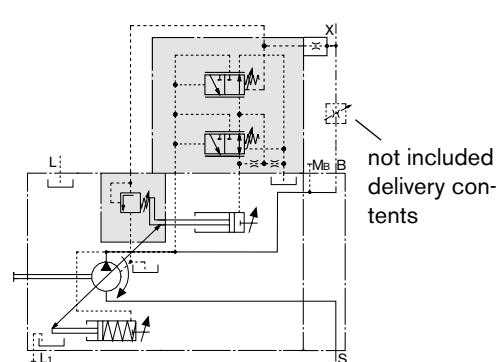

	Port for
B	Service line
S	Suction line
L, L₁	Case drain (L ₁ plugged)
X	Pilot pressure

ED – Electro-hydraulic pressure control

The ED valve is set to a certain pressure by a specified, variable solenoid current.

If there is a change at the consumer (load pressure), the position of the control piston changes.

This causes an increase or decrease in the pump swivel angle (flow) in order to maintain the electrically set pressure level.

The pump thus only delivers as much hydraulic fluid as the consumers can take. The desired pressure level can be set steplessly by varying the solenoid current.

When the solenoid current signal drops towards a zero value, the maximum output pressure is limited to p_{max} by an adjustable hydraulic pressure cut-off (secure fail safe function in case of a loss of power e.g. for use as fan drives).

The response time characteristic of the ED-control was optimized for the use as a fan drive system.

When ordering, state the type of application in clear text.

Circuit diagram ED..

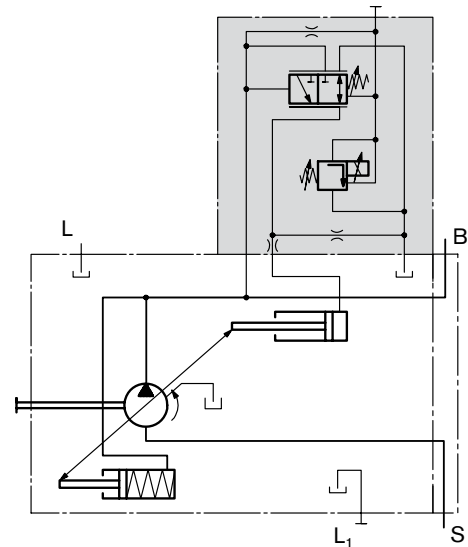

Static current-pressure characteristic ED

(measured at pump in zero stroke – negative characteristic)

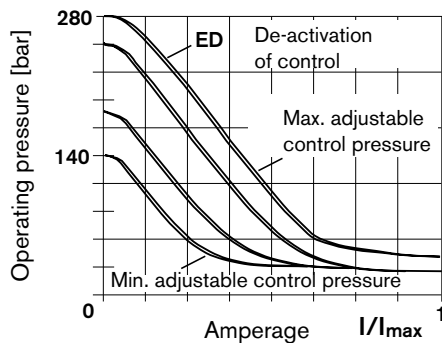

Hysteresis static current-pressure characteristic < 3 bar

Static flow-pressure characteristic

(at $n = 1500$ rpm; $t_{fluid} = 50$ °C)

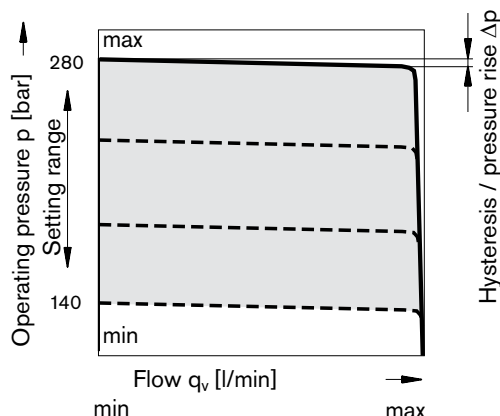

Control data

Standby standard setting 20 bar, other values on request.

Hysteresis and pressure rise _____ $\Delta p < 4$ bar.

Control flow consumption _____ 3 to 4.5 l/min.

	Port for
B	Service line
S	Suction line
L, L ₁	Case drain (L ₁ plugged)

Technical data, solenoid	ED71	ED72
Voltage	12 V (± 20 %)	24 V (± 20 %)
Control current		
Start of control at $V_{g\ min}$	100 mA	50 mA
End of control at $V_{g\ max}$	1200 mA	600 mA
Limiting current	1.54 A	0.77 A
Nominal resistance (at 20 °C)	5.5 Ω	22.7 Ω
Dither frequency	100 to 200 Hz	100 to 200 Hz
Actuated time	100 %	100 %

For type of protection, see plug design on page 40

Operating temperature range at valve -20 °C to +115 °C

ER – Electro-hydraulic pressure control

The ER valve is set to a specific pressure by a specified, variable solenoid current.

If there is a change at the consumer (load pressure), the position of the control piston changes.

This causes an increase or decrease in the pump swivel angle (flow) in order to maintain the electrically set pressure level.

The pump thus only delivers as much hydraulic fluid as the consumers can take. The desired pressure level can be set steplessly by varying the solenoid current.

When the solenoid current signal drops towards a zero value, the pump's output pressure is limited to p_{min} (standby level).

Observe the project planning note on page 2.

Static current-pressure characteristic ER

(measured with pump in zero stroke – positive characteristic)

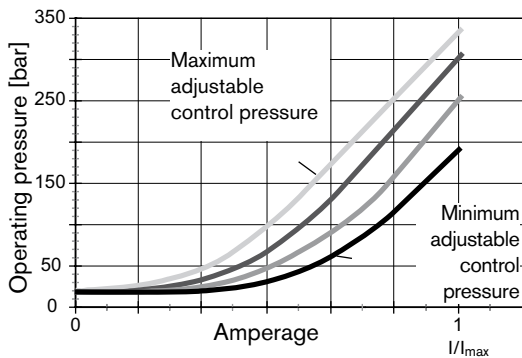

Hysteresis static current-pressure characteristic < 3 bar

Influence of pressure setting on standby by ± 2 bar

Static flow-pressure characteristic

(at $n = 1500$ rpm; $t_{fluid} = 50$ °C)

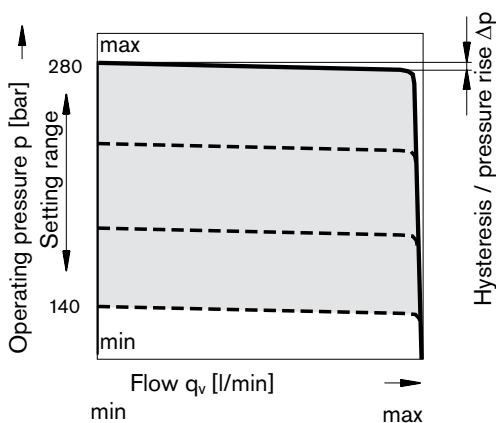

Control data

Standby standard setting 14 bar, other values on request.

Hysteresis and pressure rise _____ $\Delta p < 4$ bar.

Control flow consumption _____ 3 to 4.5 l/min.

Circuit diagram ER..

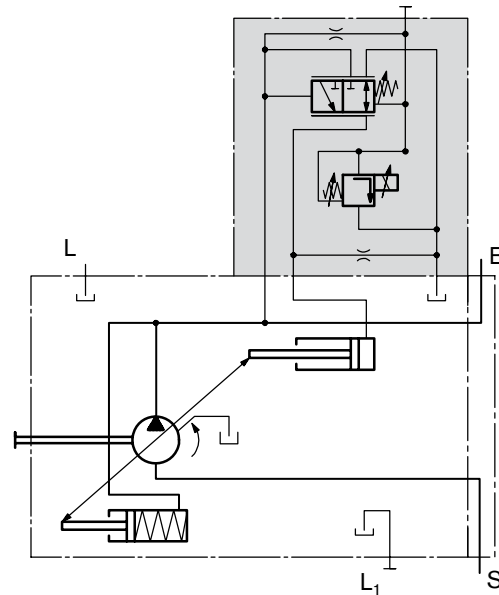

	Port for
B	Service line
S	Suction line
L, L ₁	Case drain (L ₁ plugged)

Technical data, solenoid	ED71	ED72
Voltage	12 V (± 20 %)	24 V (± 20 %)
Control current		
Start of control at $V_{g\ min}$	100 mA	50 mA
End of control at $V_{g\ max}$	1200 mA	600 mA
Limiting current	1.54 A	0.77 A
Nominal resistance (at 20 °C)	5.5 Ω	22.7 Ω
Dither frequency	100 to 200 Hz	100 to 200 Hz
Actuated time	100 %	100 %
For type of protection, see plug design on page 40		
Operating temperature range at valve -20 °C to +115 °C		

Dimensions size 71

Before finalizing your design request a certified installation drawing. Dimensions in mm.

DRF/DRS – Pressure and flow control

port plate 11; mounting flange D; clockwise rotation

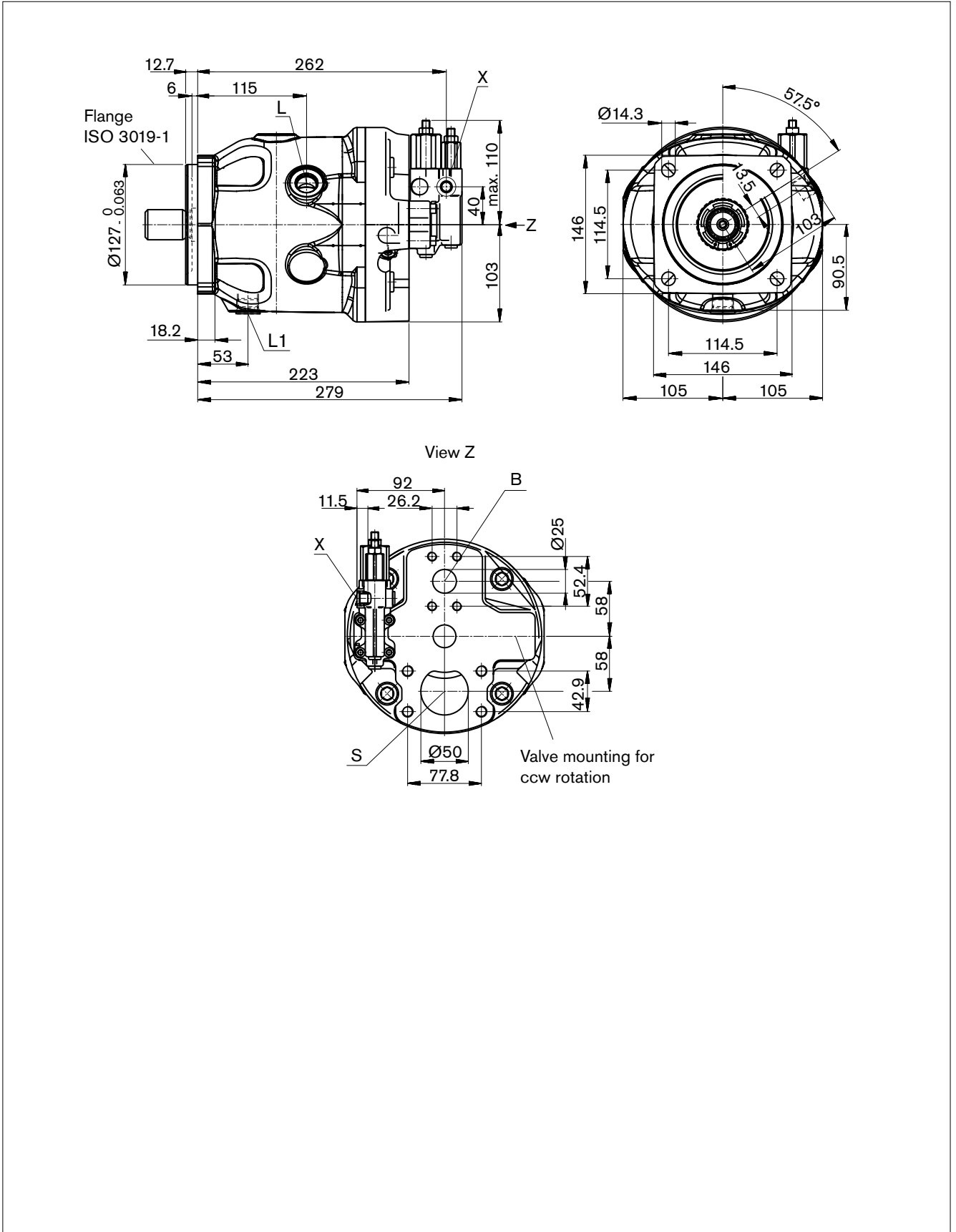

For other details on ports and shaft end, see page 17

Dimensions size 71

Before finalizing your design request a certified installation drawing. Dimensions in mm.

DRF/DRS – Pressure and flow control

Port plate 12; mounting flange C; clockwise rotation

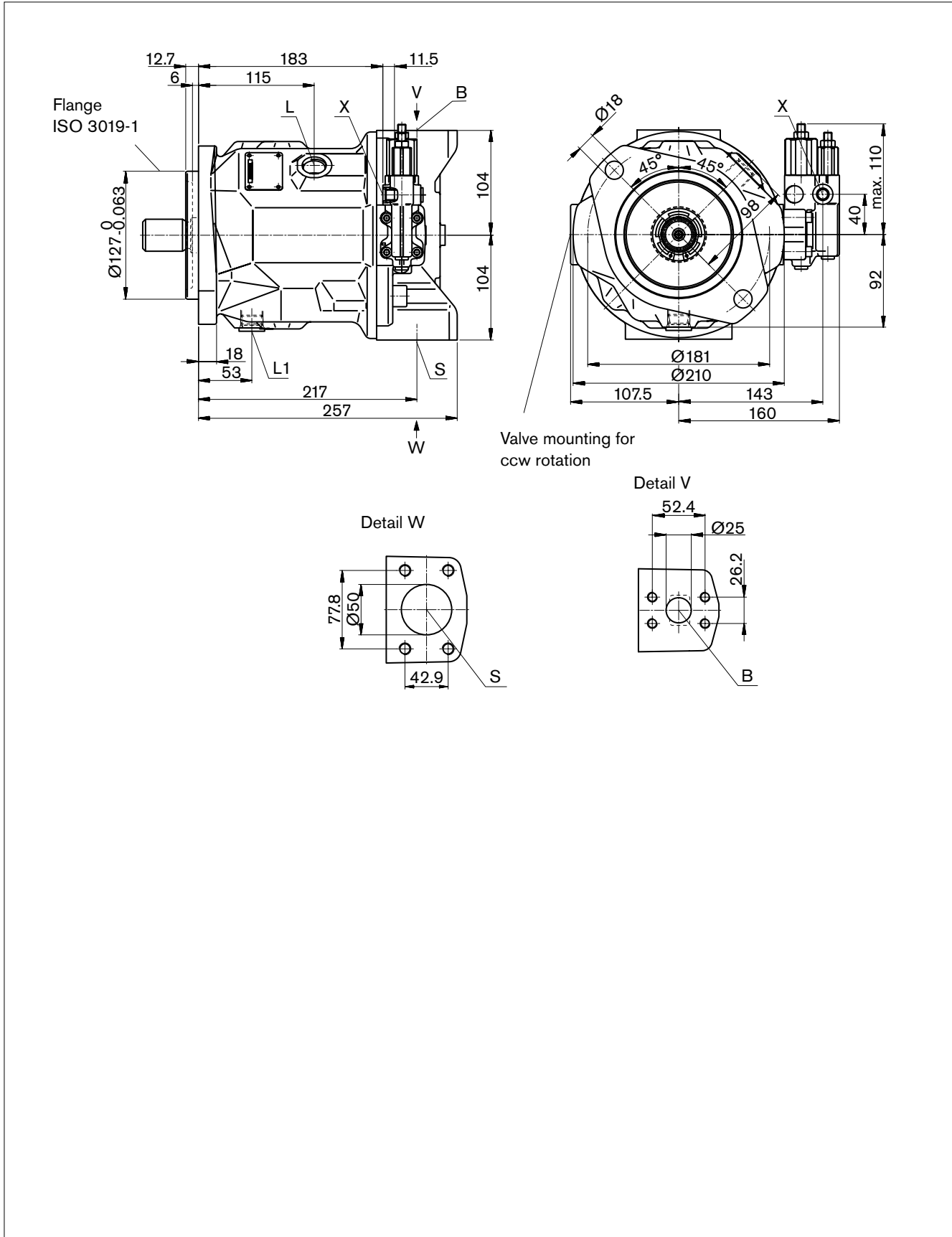

For other details on ports and shaft end, see page 17

Dimensions size 71

Before finalizing your design request a certified installation drawing. Dimensions in mm.

Drive shaft

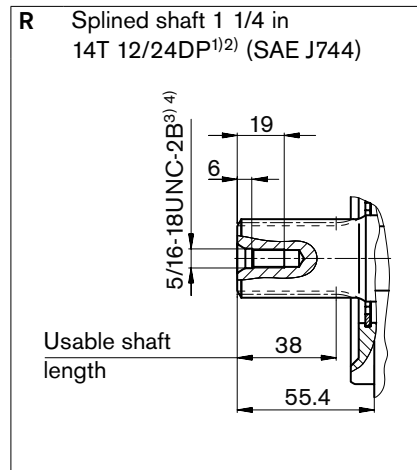
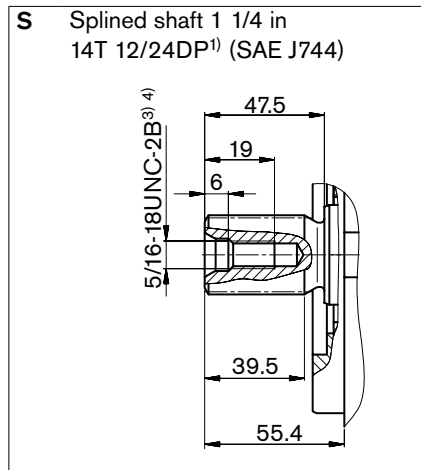

Ports

Designation	Port for	Standard	Size ⁴⁾	Maximum pressure [bar] ⁵⁾	State
B	Service line	SAE J518 ⁶⁾	1 in	350	O
	Fastening thread	DIN 13	M10 x 1.5; 17 deep		
S	Suction	SAE J518 ⁶⁾	2 in	10	O
	Fastening thread	DIN 13	M12 x 1.75; 20 deep		
L	Case drain fluid	ISO 11926 ⁷⁾	7/8-14 UNF-2B; 12 deep	2	O ⁸⁾
L ₁	Case drain fluid	ISO 11926 ⁷⁾	7/8-14 UNF-2B; 12 deep	2	X ⁸⁾
X	Pilot pressure	ISO 11926	7/16-20 UNF-2B; 12 deep	350	O
X	Pilot pressure DG-control	DIN ISO 228	G 1/4 in ; 12 deep	350	O

1) ANSI B92.1a-1976, 30° pressure angle, flat root, side fit, tolerance class 5

2) Splines according to ANSI B92.1a, run out of spline is a deviation from standard

3) Thread according to ASME B1.1

4) For the maximum tightening torques the general instructions on page 44 must be observed.

5) Depending on the application, short-term pressure spikes can occur. Consider this when selecting measuring equipment and fittings. Pressure values in bar absolute

6) Only dimensions according to SAE J518, metric fastening thread deviating from the standard

7) The spot face can be deeper than as specified in the standard

8) Depending on the installation position, L or L₁ must be connected (see also pages 42 and 43)

O = Must be connected (plugged on delivery)

X = Plugged (in normal operation)

Dimensions size 71, port plate 11

Before finalizing your design request a certified installation drawing. Dimensions in mm.

DG

Two-point control, direct controlled

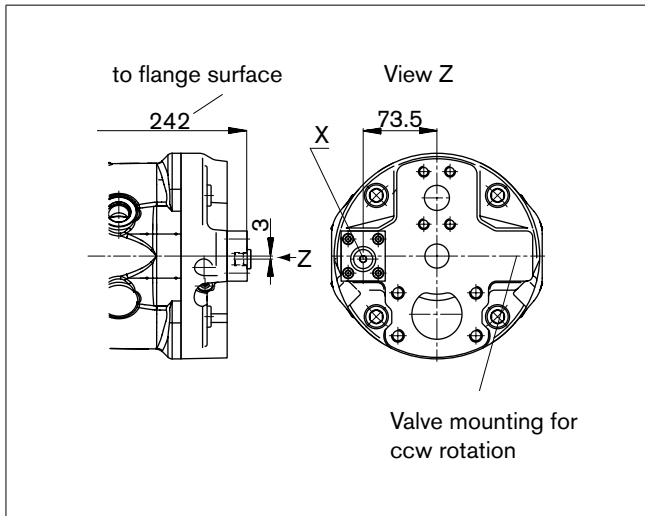

L.A.D;

Pressure, flow and power control

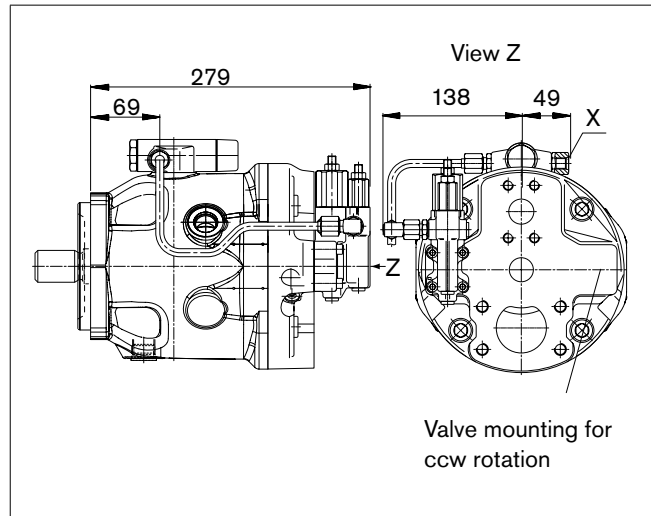

DR

Pressure control

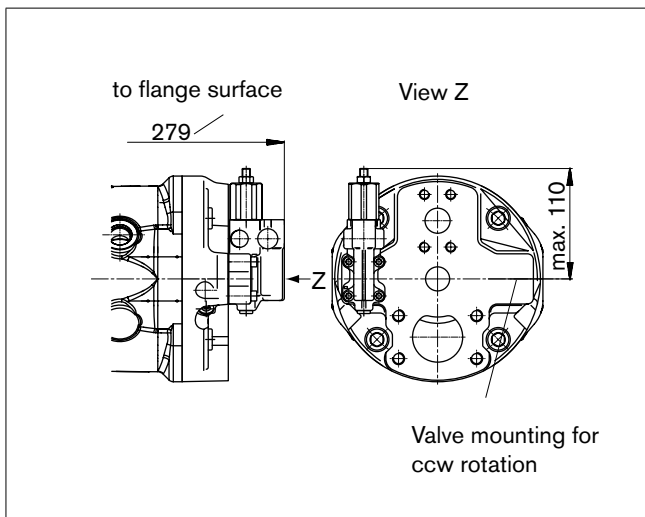

ED7. / ER7.

Electro-hydraulic pressure control

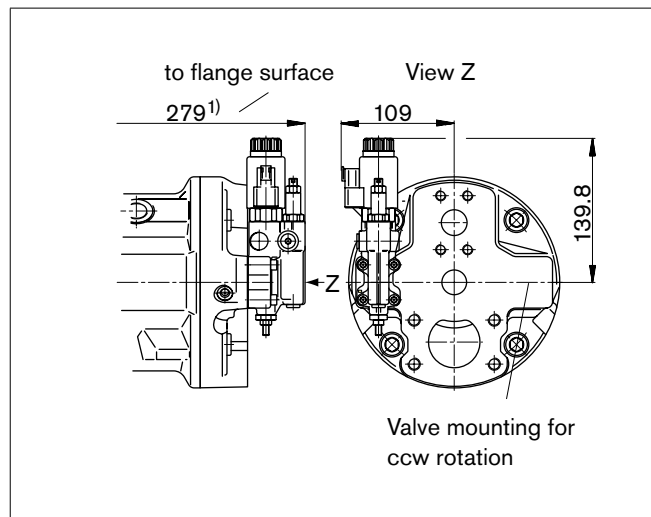

DRG

Pressure control, remotely operated

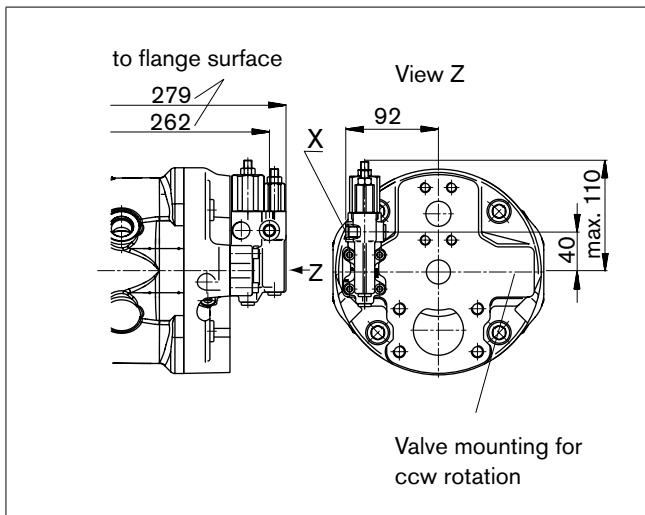

1) ER7.: 314 mm when using a sandwich plate pressure reducing valve.

Dimensions size 71, port plate 12

Before finalizing your design request a certified installation drawing. Dimensions in mm.

DG

Two-point control, directly operated

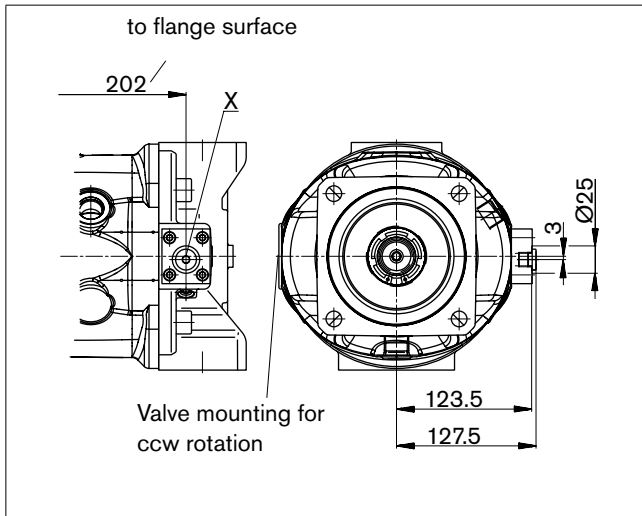

LA.D

Pressure, flow and power control

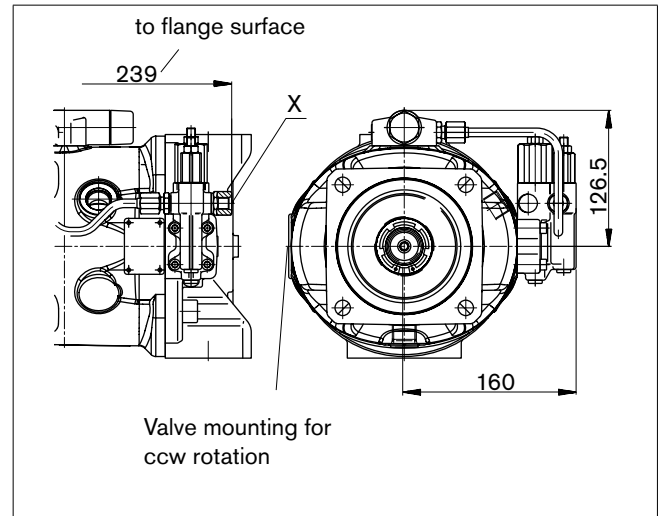

DR

Pressure control

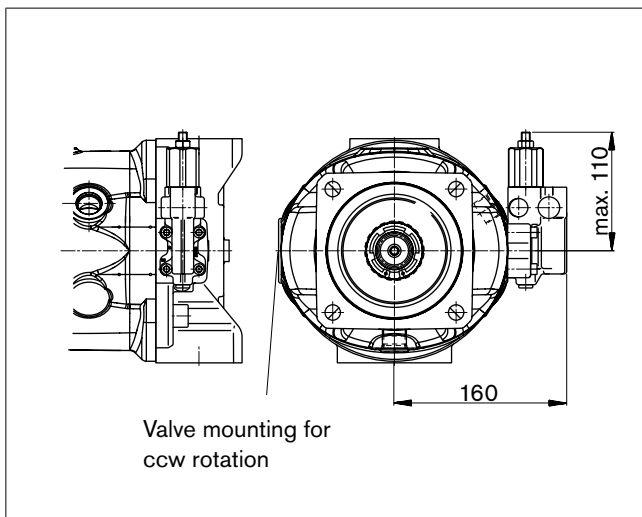

ED7. / ER7.

Electro-hydraulic pressure control

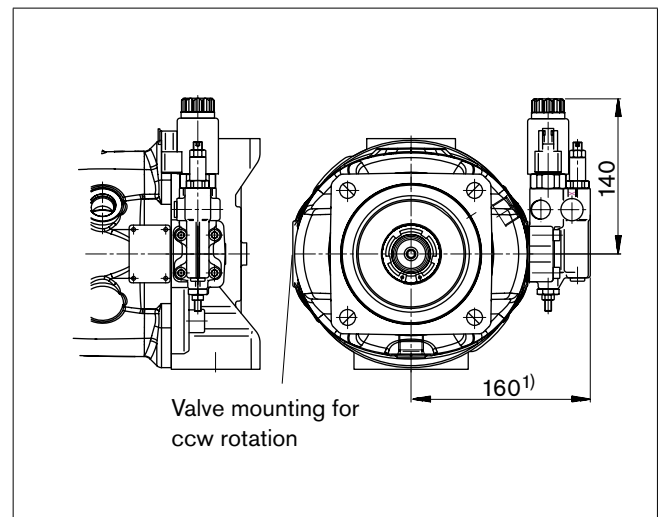

DRG

Pressure control, remotely operated

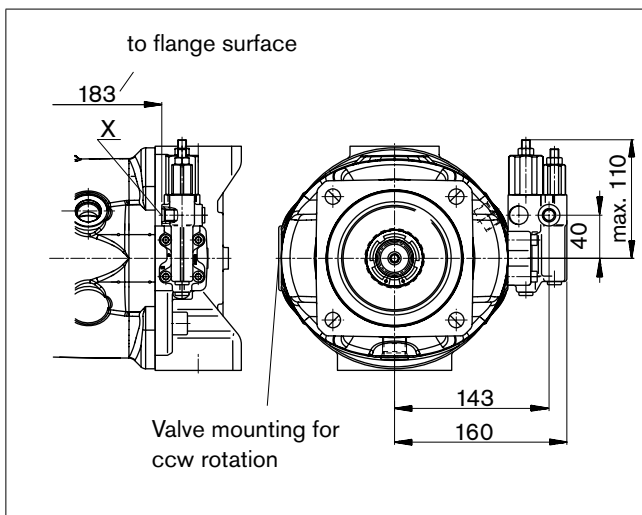

1) ER7.: 195 mm if using a sandwich plate pressure reducing valve.

Dimensions size 100

Before finalizing your design request a certified installation drawing. Dimensions in mm.

DRF/DRS – Pressure and flow control

Port plate 11; mounting flange D; clockwise rotation

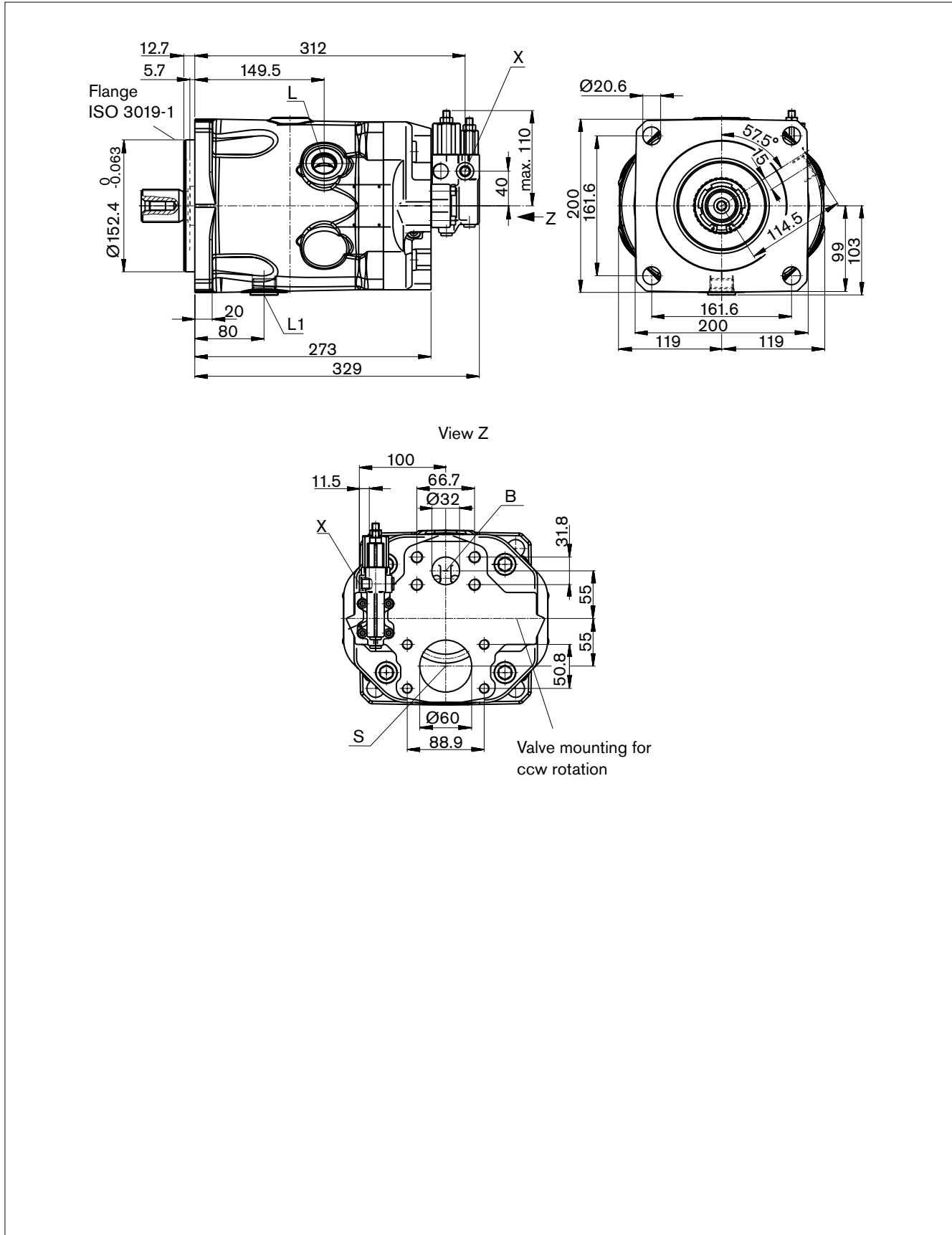

For other details on ports and shaft end, see page 22

Dimensions size 100

Before finalizing your design request a certified installation drawing. Dimensions in mm.

DRF/DRS – Pressure and flow control

Port plate 12; mounting flange C; clockwise rotation

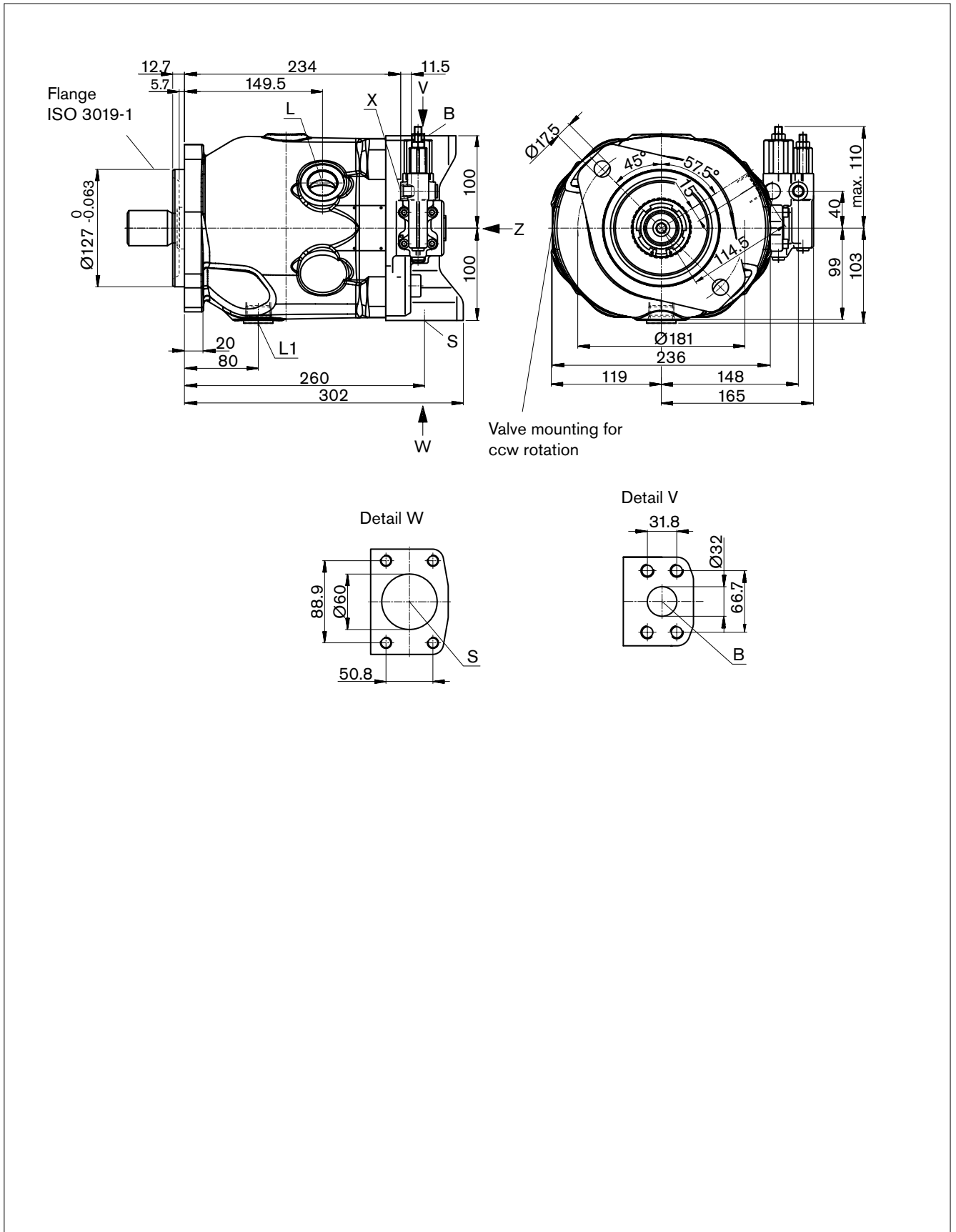

For other details on ports and shaft end, see page 22

Dimensions size 100

Before finalizing your design request a certified installation drawing. Dimensions in mm.

Drive shaft

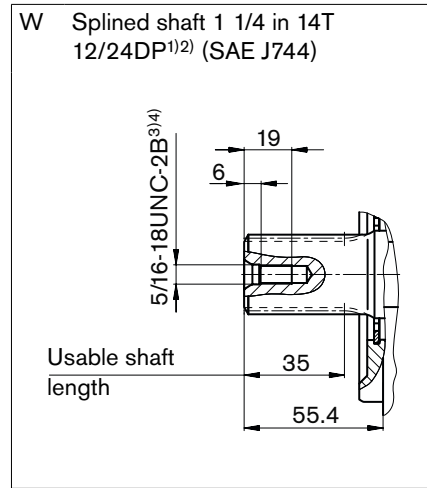
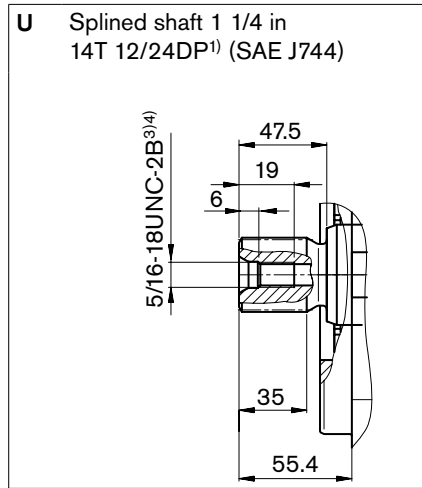
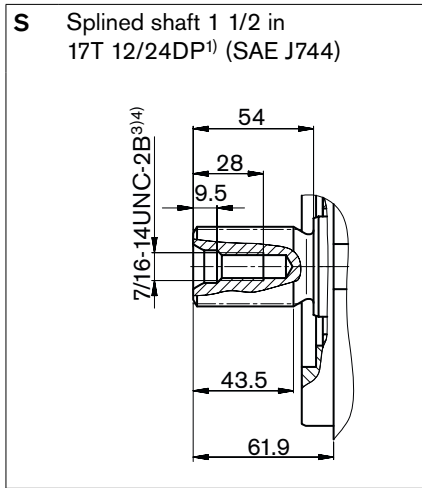

Ports

Designation	Port for	Standard	Size ⁴⁾	Maximum pressure [bar] ⁵⁾	State
B	Service line	SAE J518 ⁶⁾	1 1/4 in	350	O
	Fastening thread	DIN 13	M14 x 2; 19 deep		
S	Suction	SAE J518 ⁶⁾	2 1/2 in	10	O
	Fastening thread	DIN 13	M12 x 1.75; 17 deep		
L	Case drain fluid	ISO 11926 ⁷⁾	1 1/16-12 UNF-2B; 15 deep	2	O ⁸⁾
L ₁	Case drain fluid	ISO 11926 ⁷⁾	1 1/16-12 UNF-2B; 15 deep	2	X ⁸⁾
X	Pilot pressure	ISO 11926	7/16-20 UNF-2B; 12 deep	350	O
X	Pilot pressure DG-control	DIN ISO 228	G 1/4 in ; 12 deep	350	O

- 1) ANSI B92.1a-1976, 30° pressure angle, flat root, side fit, tolerance class 5
 - 2) Splines according to ANSI B92.1a, run out of spline is a deviation from standard
 - 3) Thread according to ASME B1.1
 - 4) For the maximum tightening torques the general instructions on page 44 must be observed.
 - 5) Depending on the application, short-term pressure spikes can occur. Consider this when selecting measuring equipment and fittings. Pressure values in bar absolute
 - 6) Only dimensions according to SAE J518, metric fastening thread deviating from the standard
 - 7) The spot face can be deeper than as specified in the standard
 - 8) Depending on the installation position, L or L₁ must be connected (see also pages 42 and 43)
- O = Must be connected (plugged on delivery)
X = Plugged (in normal operation)

Dimensions size 100, port plate 11

Before finalizing your design request a certified installation drawing. Dimensions in mm.

DG

Two-point control, directly operated

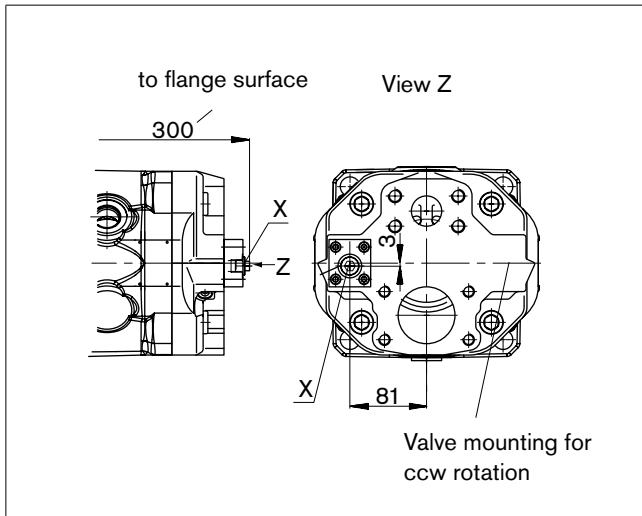

L.A.D.

Pressure, flow and power control

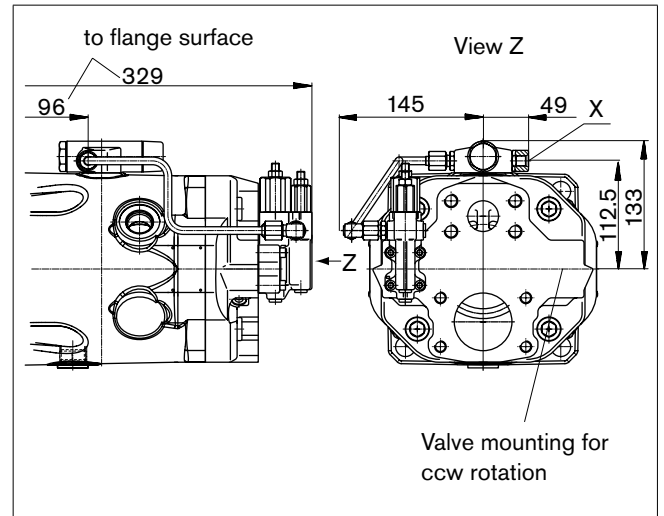

DR

Pressure control

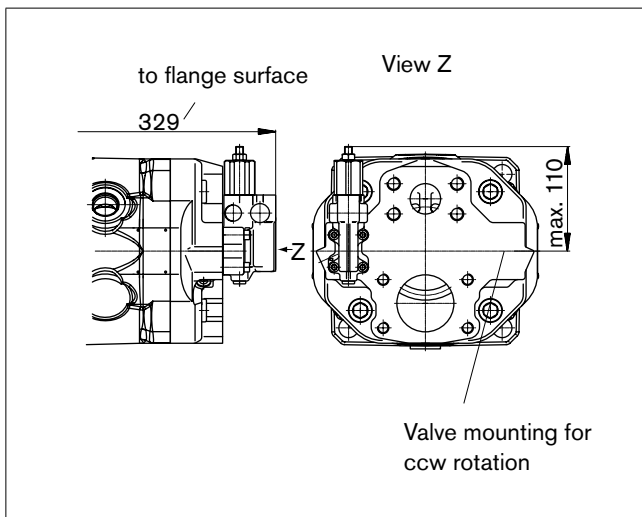

ED7. / ER7.

Electro-hydraulic pressure control

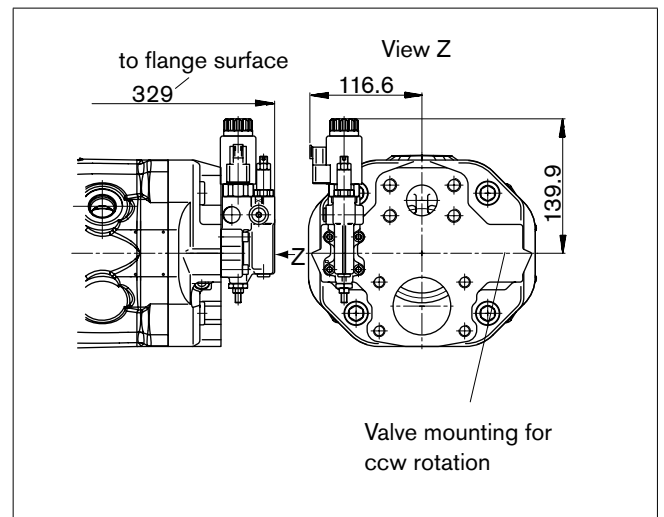

DRG

Pressure control, remotely operated

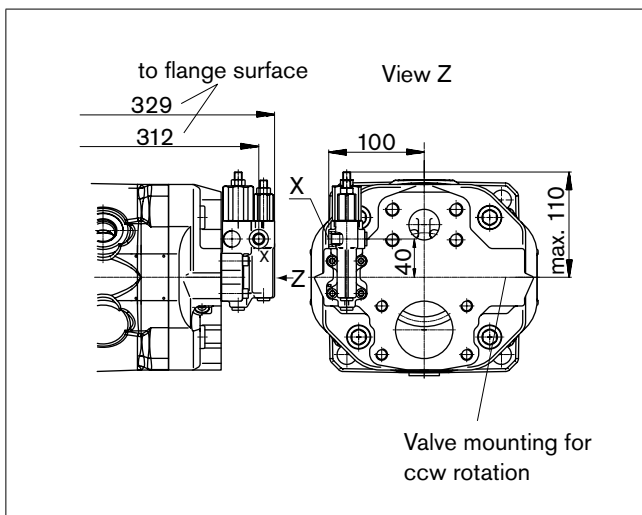

1) ER7.: 364 mm if using a sandwich plate pressure reducing valve.

Dimensions size 100, port plate 12

Before finalizing your design request a certified installation drawing. Dimensions in mm.

DG

Two-point control, directly operated

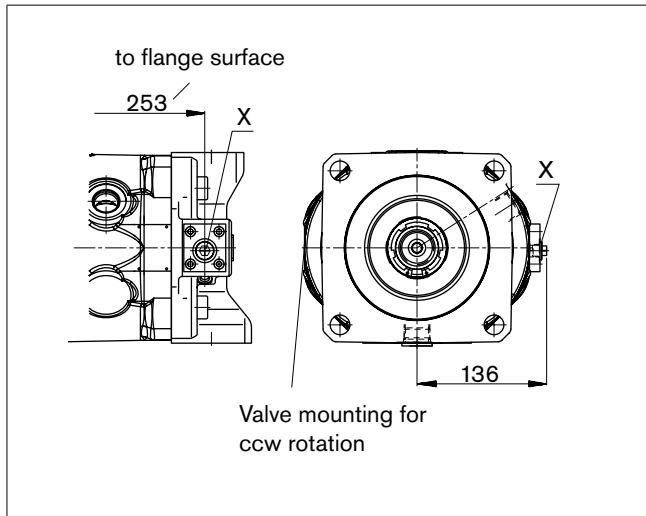

L.A.D.

Pressure, flow and power control

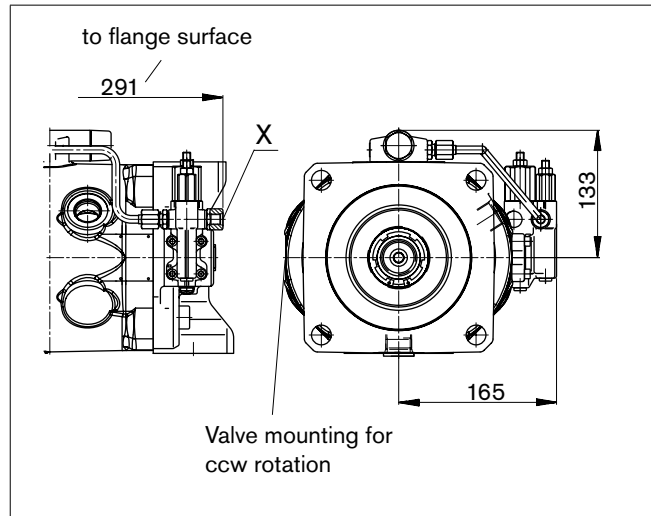

DR

Pressure control

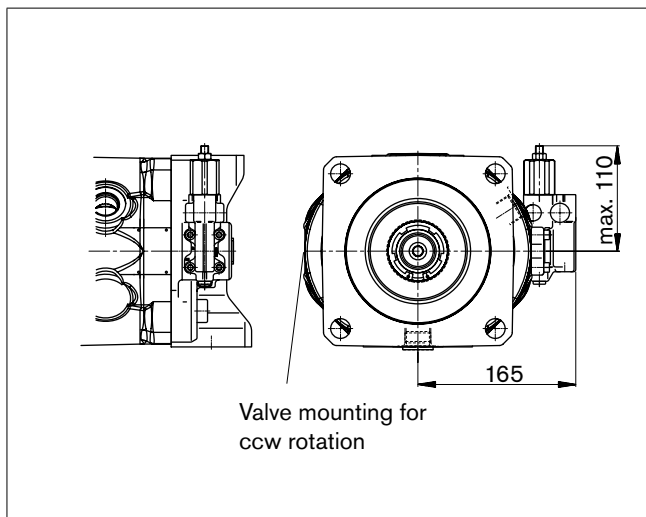

ED7. / ER7.

Electro-hydraulic pressure control

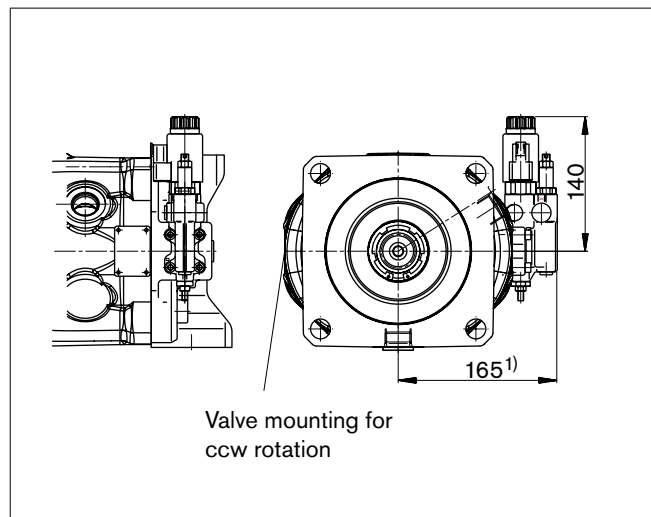

DRG

Pressure control, remotely operated

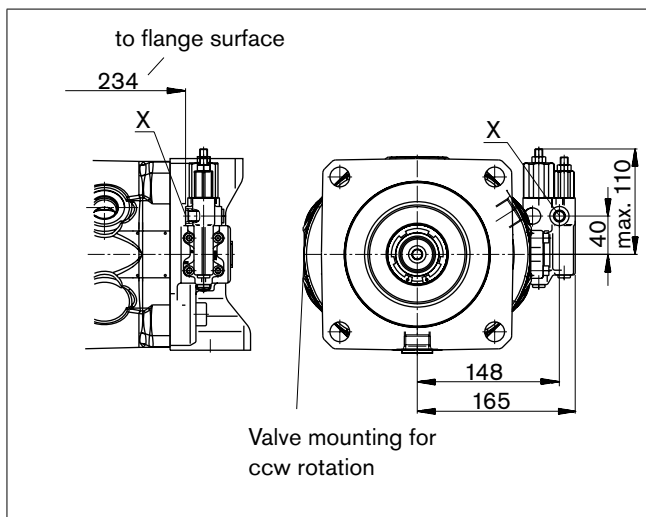

1) ER7.: 200 mm when using a sandwich plate pressure reducing valve.

Dimensions size 140

Before finalizing your design request a certified installation drawing. Dimensions in mm.

DRF/DRS – Pressure and flow control

Port plate 11/12; mounting flange D; clockwise rotation

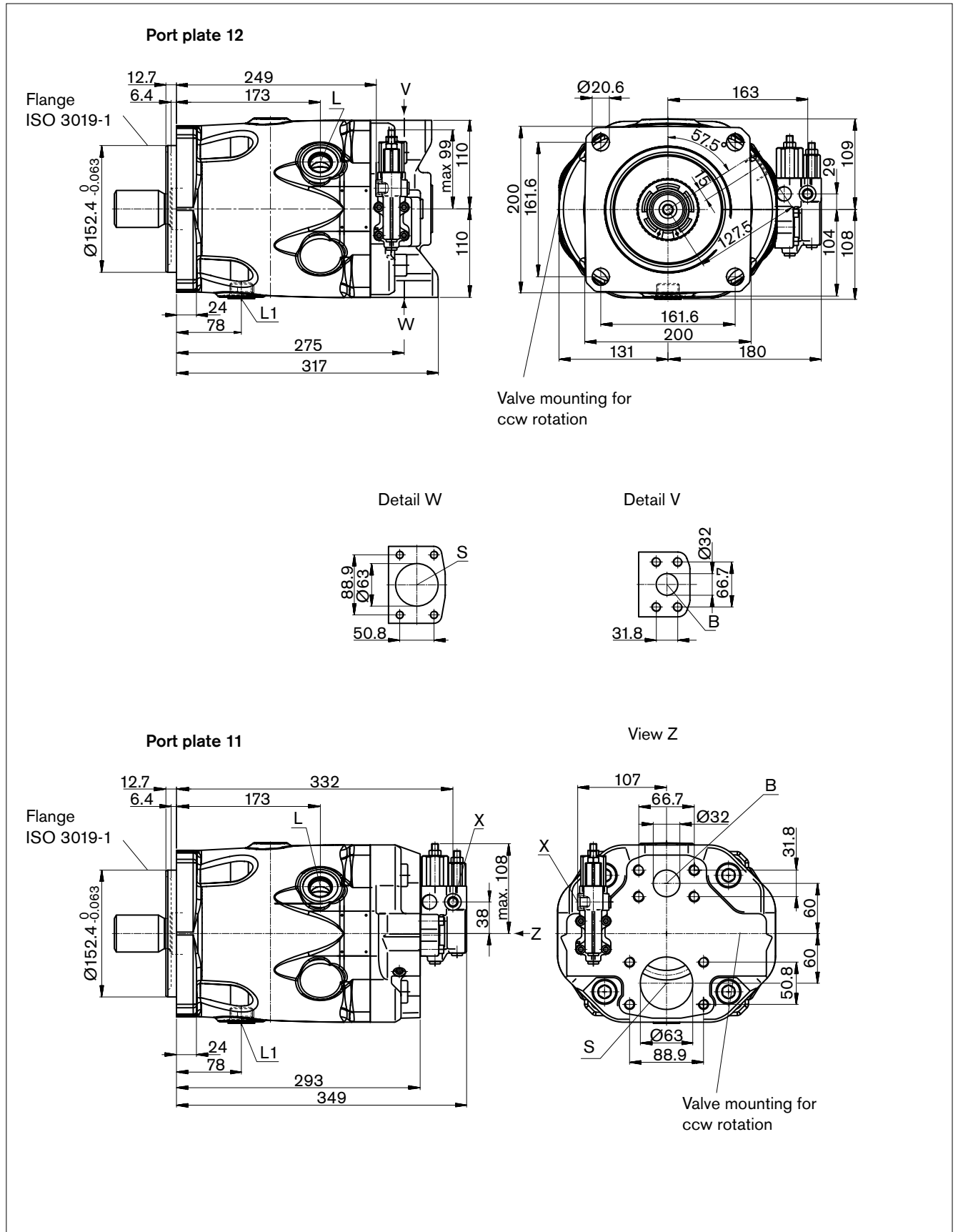

For other details on ports and shaft end, see page 27

Dimensions size 140

Before finalizing your design request a certified installation drawing. Dimensions in mm.

DRF/DRS – Pressure and flow control

Port plate 11/12; mounting flange C; clockwise rotation

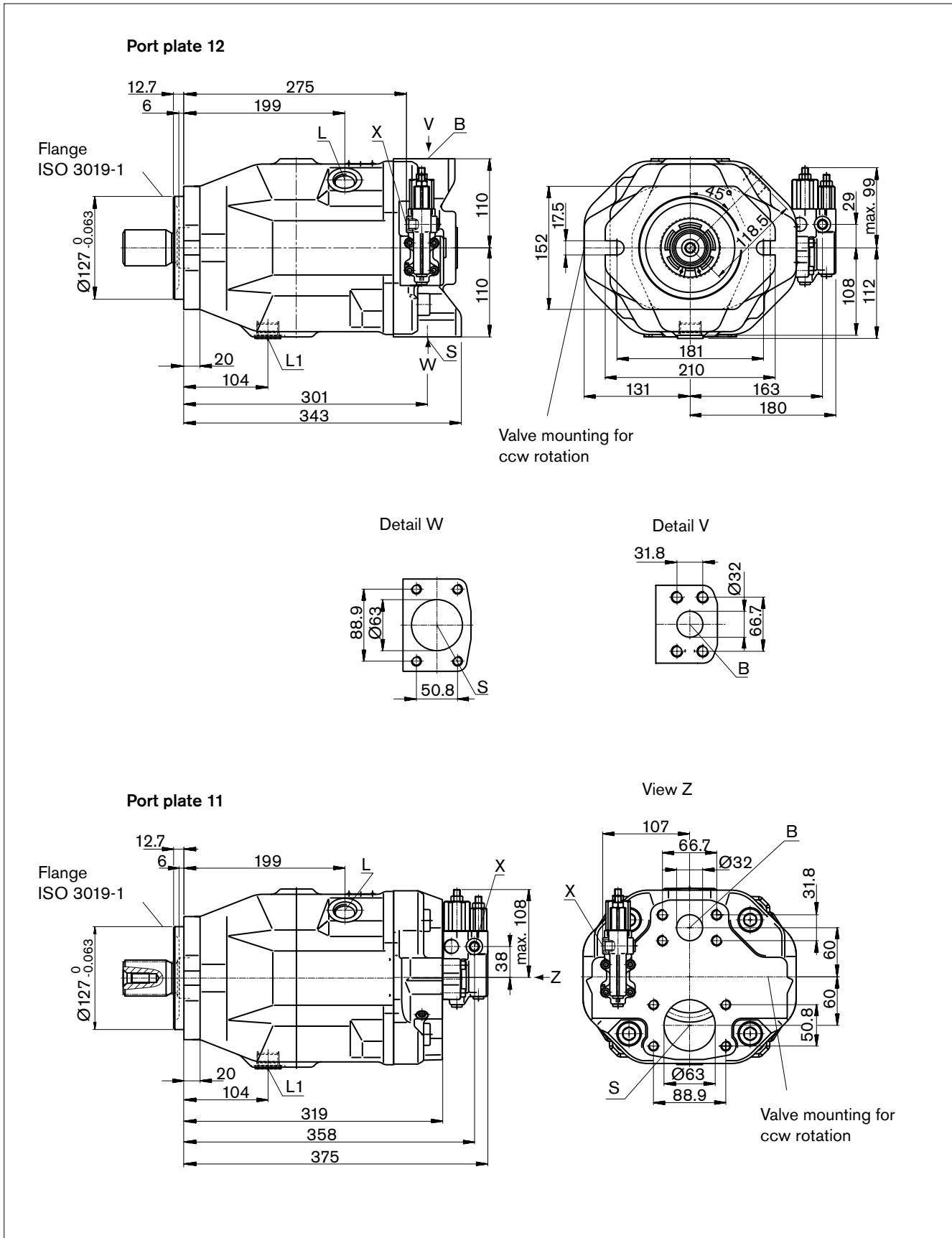

For other details on ports and shaft end, see page 27

Dimensions size 140

Before finalizing your design request a certified installation drawing. Dimensions in mm.

Drive shaft

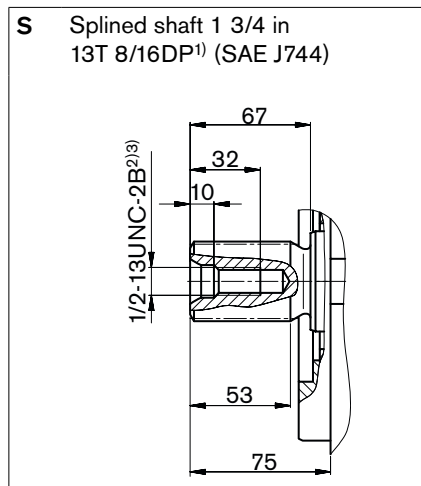

Ports

Designation	Port for	Standard	Size ³⁾	Maximum pressure [bar] ⁴⁾	State
B	Service line	SAE J518 ⁵⁾	1 1/4 in	350	O
	Fastening thread	DIN 13	M14 x 2; 19 deep		
S	Suction	SAE J518 ⁵⁾	2 1/2 in	10	O
	Fastening thread	DIN 13	M12 x 1.75; 17 deep		
L	Case drain fluid	ISO 11926 ⁶⁾	1 1/16-12 UNF-2B; 15 deep	2	O ⁷⁾
L ₁	Case drain fluid	ISO 11926 ⁶⁾	1 1/16-12 UNF-2B; 15 deep	2	X ⁷⁾
X	Pilot pressure	ISO 11926	7/16-20 UNF-2B; 12 deep	350	O
X	Pilot pressure DG-control	DIN ISO 228	G 1/4 in; 12 deep	350	O

1) ANSI B92.1a-1976, 30° pressure angle, flat root, side fit, tolerance class 5

2) Thread according to ASME B1.1

3) For the maximum tightening torques the general instructions on page 44 must be observed

4) Depending on the application, short-term pressure spikes can occur. Consider this when selecting measuring equipment and fittings. Pressure values in bar absolute.

5) Only dimensions according to SAE J518, metric fastening thread deviating from the standard

6) The spot face can be deeper than as specified in the standard

7) Depending on the installation position, L or L₁ must be connected (see also pages 42 and 43)

O = Must be connected (plugged on delivery)

X = Plugged (in normal operation)

Dimensions size 140, port plate 11

Before finalizing your design request a certified installation drawing. Dimensions in mm.

DG

Two-point control, direct controlled; flange D

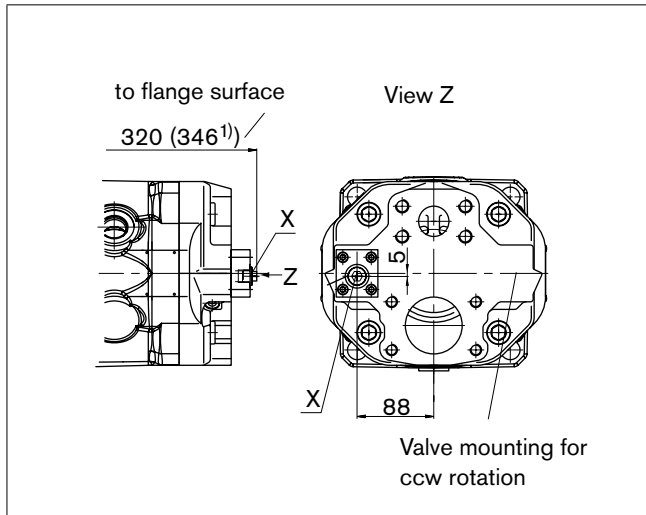

L.A.D.

Pressure, flow and power control; flange D

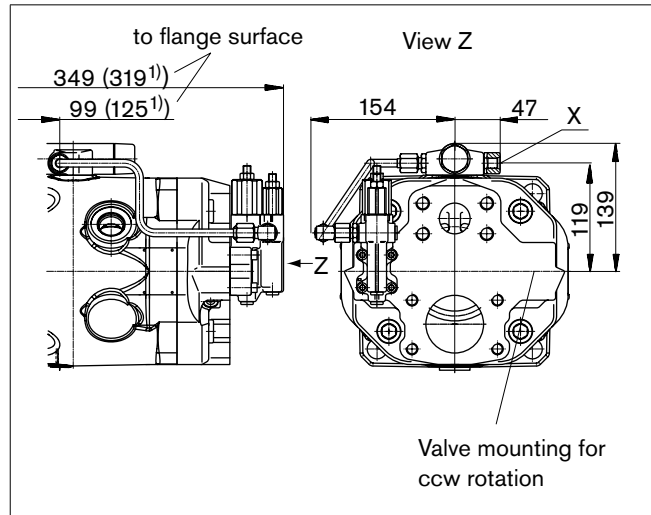

DR

Pressure control; flange D

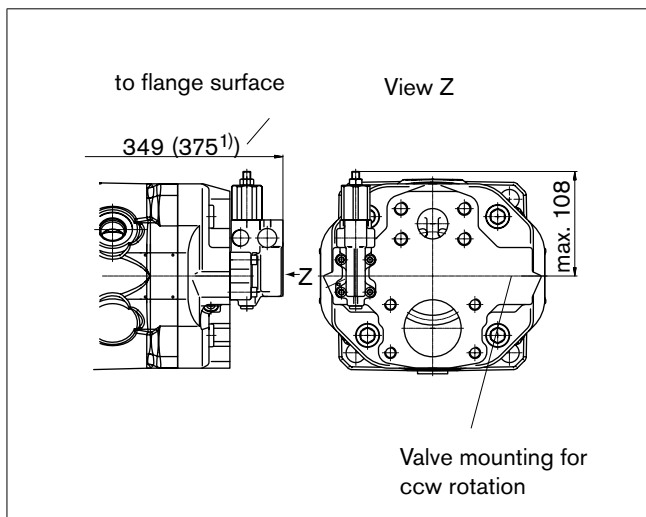

ED7. / ER7.

Electro-hydraulic pressure control; flange D

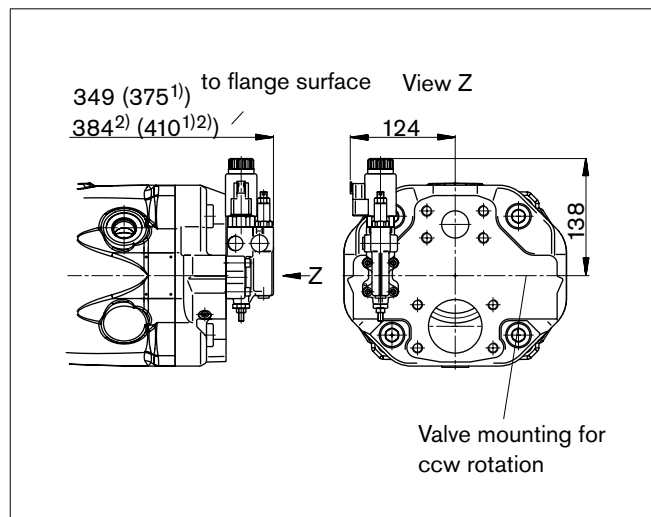

DRG

Pressure control, remotely operated; flange D

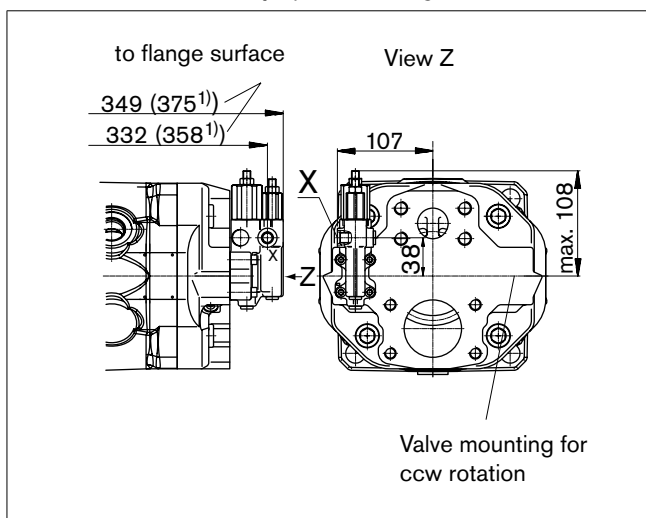

1) Dimensions of mounting flange C

2) Dimensions of control ER7 when using a sandwich plate pressure reducing valve.

Dimensions size 140, port plate 12

Before finalizing your design request a certified installation drawing. Dimensions in mm.

DG

Two-point control, direct controlled; flange D

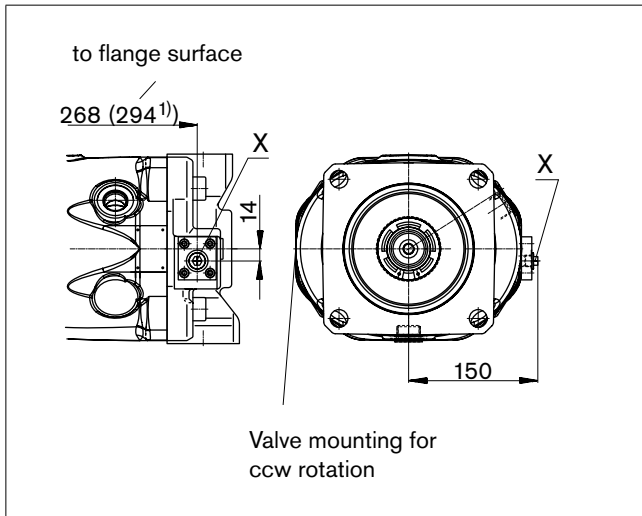

LA.D.

Pressure, flow and power control; flange D

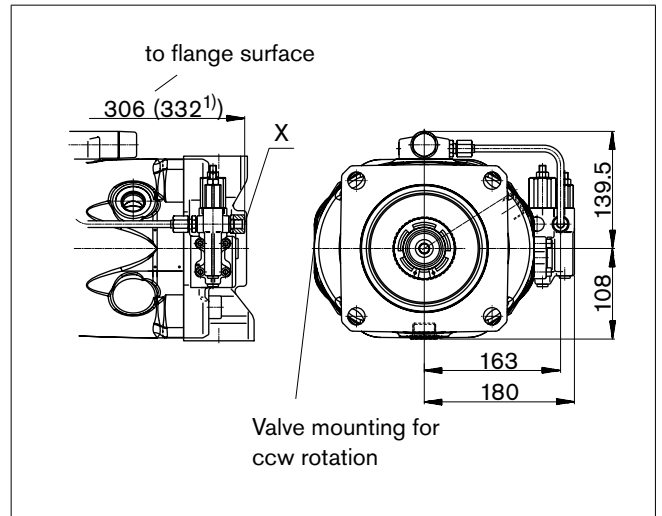

DR

Pressure control; flange D

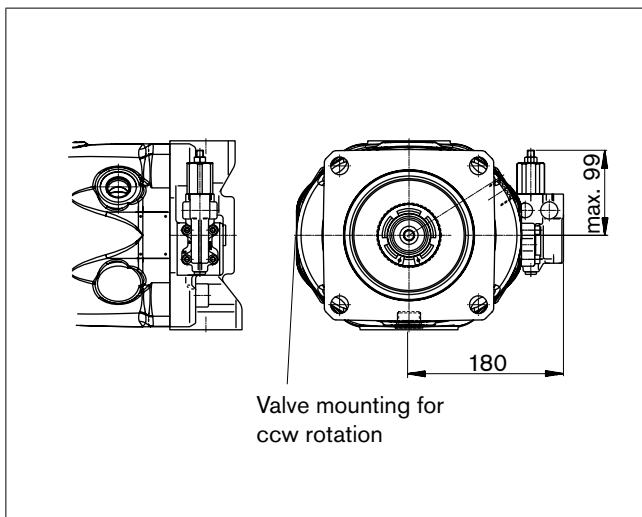

ED7. / ER7.

Electro-hydraulic pressure control; flange D

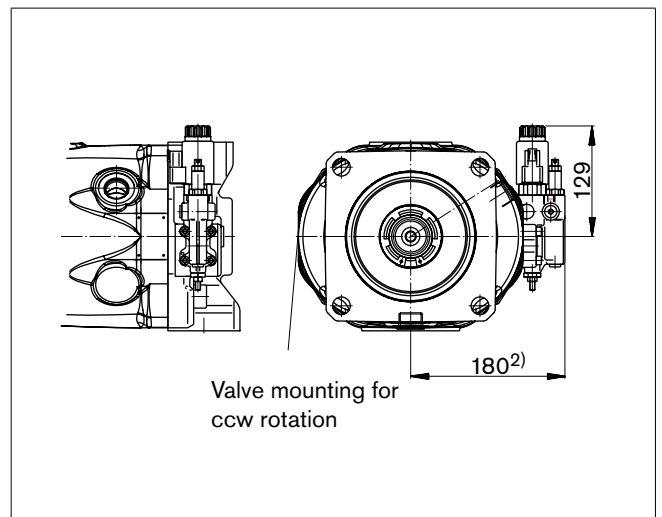

DRG

Pressure control, remotely operated; flange D

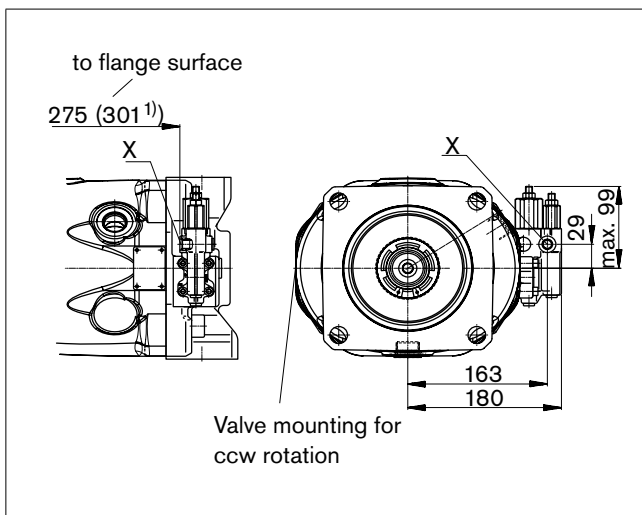

1) Dimensions of mounting flange C

2) ER7.: 215 mm when using a sandwich plate pressure reducing valve.

Dimensions size 180

Before finalizing your design request a certified installation drawing. Dimensions in mm.

DRF/DRS – Pressure and flow control

Port plates 11 and 22U; clockwise rotation

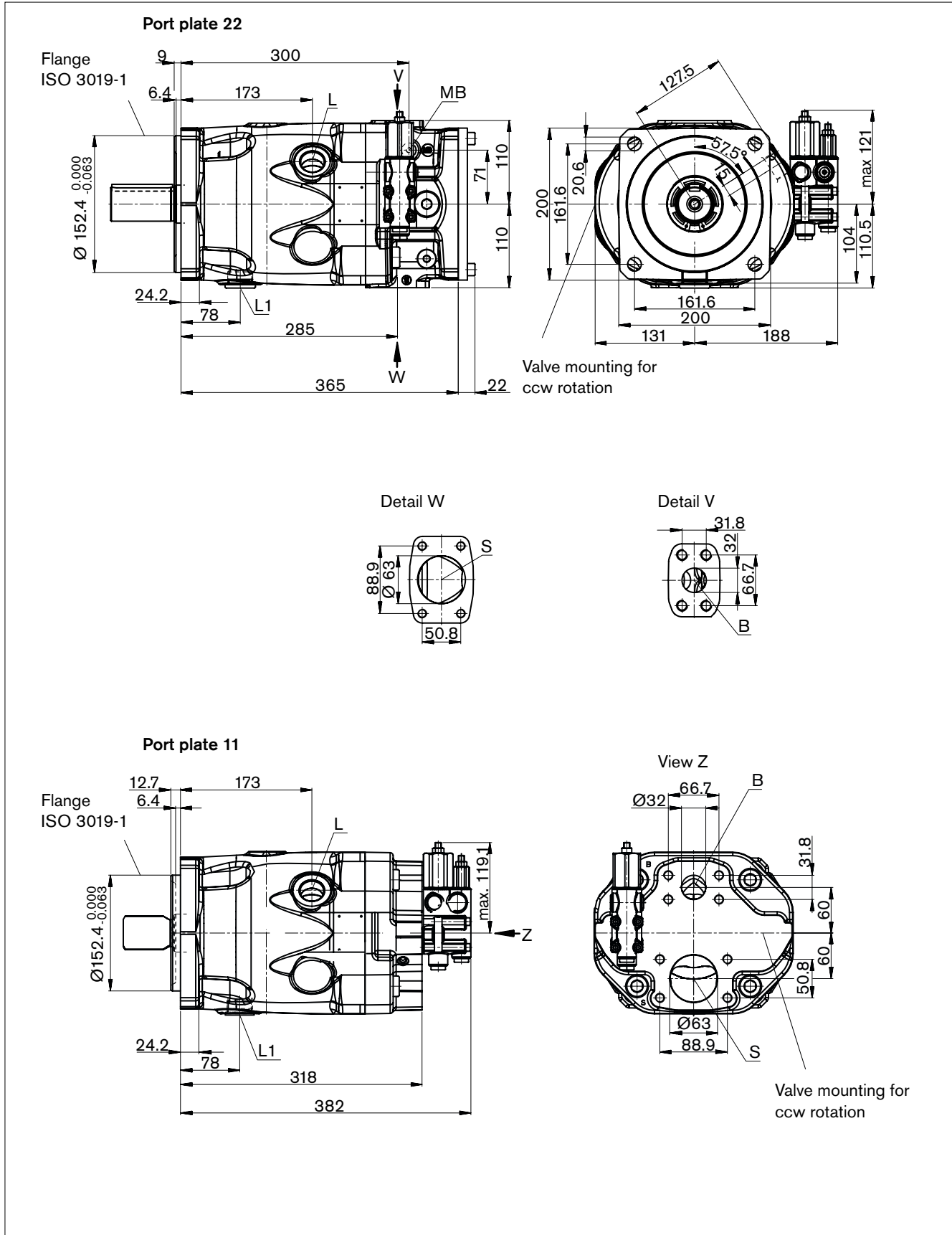

Dimensions size 180

Before finalizing your design request a certified installation drawing. Dimensions in mm.

Drive shaft

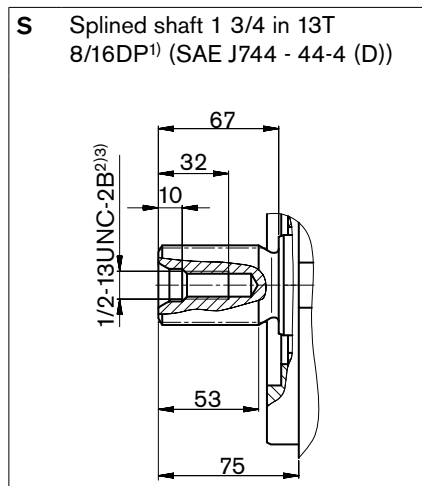

Ports

Designation	Port for	Standard	Size ³⁾	Maximum pressure [bar] ⁴⁾	State
B	Service line	SAE J518 ⁵⁾	1 1/4 in	350	O
	Fastening thread	DIN 13	M14 x 2; 19 deep		
S	Suction	SAE J518 ⁵⁾	2 1/2 in	10	O
	Fastening thread	DIN 13	M12 x 1.75; 17 deep		
L	Case drain fluid	ISO 11926 ⁶⁾	1 5/16-12 UN-2B; 15 deep	2	O ⁷⁾
L ₁	Case drain fluid	ISO 11926 ⁶⁾	1 5/16-12 UN-2B; 15 deep	2	X ⁷⁾
X	Pilot pressure	ISO 11926	7/16-20 UNF-2B; 12 deep	350	O
X	Pilot pressure DG-control	DIN ISO 228	G 1/4 in ; 12 deep	350	O
M _B	Measuring pressure in B	DIN 3852 ⁶⁾	G 1/4; 12 deep	350	X

1) ANSI B92.1a-1976, 30° pressure angle, flat root, side fit, tolerance class 5

2) Thread according to ASME B1.1

3) For the maximum tightening torques the general instructions on page 44 must be observed.

4) Depending on the application, short-term pressure spikes can occur. Consider this when selecting measuring equipment and fittings. Pressure values in bar absolute.

5) Only dimensions according to SAE J518, metric fastening thread deviating from the standard

6) The spot face can be deeper than as specified in the standard

7) Depending on the installation position, L or L₁ must be connected (see also pages 42 and 43)

O = Must be connected (plugged on delivery)

X = Plugged (in normal operation)

Dimensions size 180, port plate 11

Before finalizing your design request a certified installation drawing. Dimensions in mm.

DG

Two-point control, directly operated

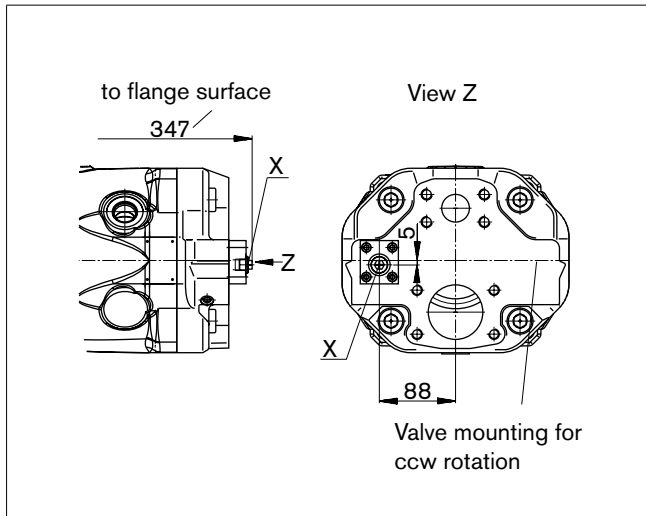

L.A.D

Pressure, flow and power control

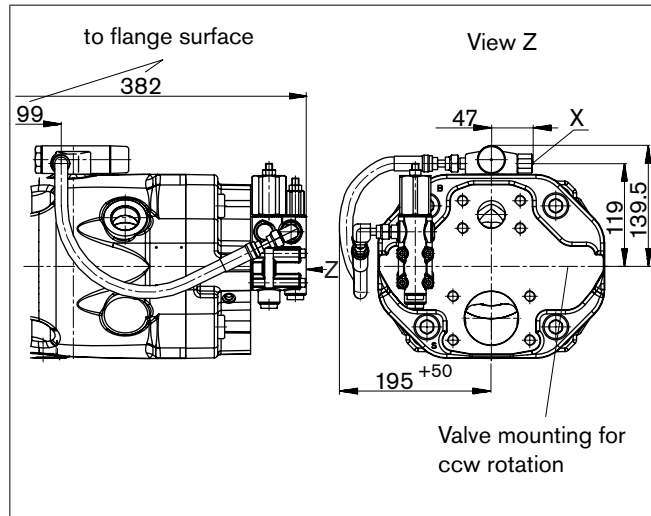

DR

Pressure control

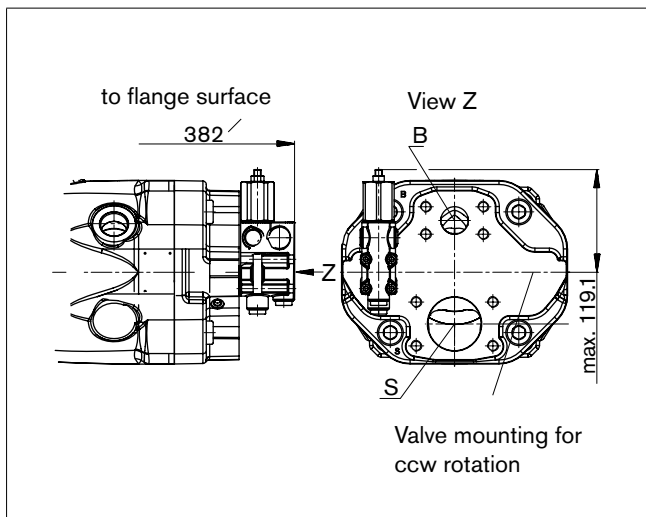

ED7. / ER7.

Electro-hydraulic pressure control

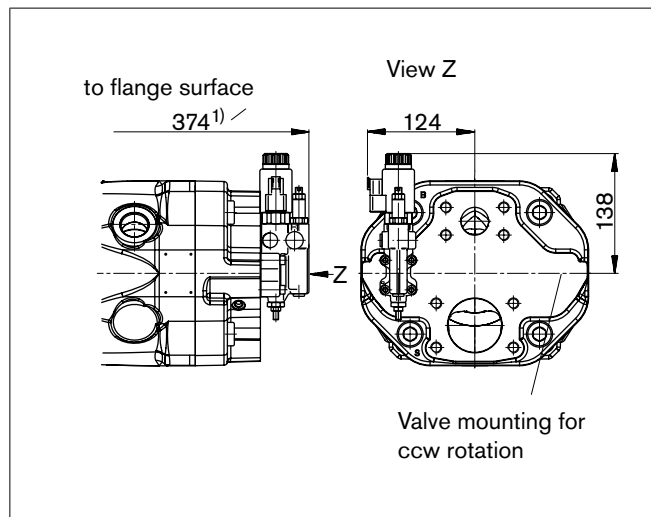

DRG

Pressure control, remotely operated

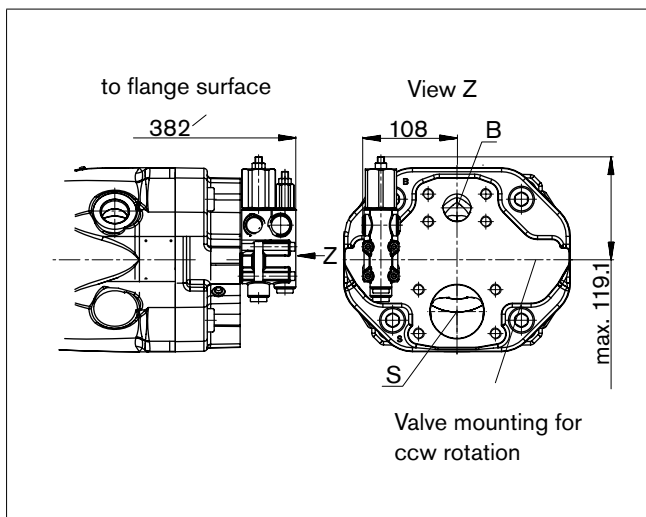

1) ER7.: 409 mm when using a sandwich plate pressure reducing valve.

Dimensions size 180, port plate 22

Before finalizing your design request a certified installation drawing. Dimensions in mm.

DG

Two-point control, directly operated

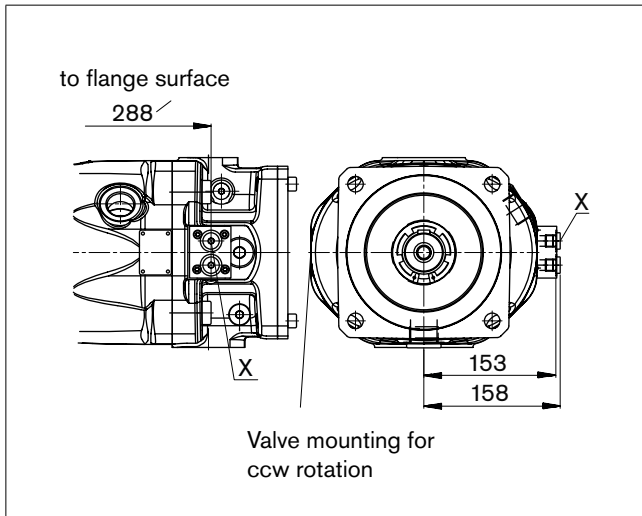

LA.D

Pressure, flow and power control

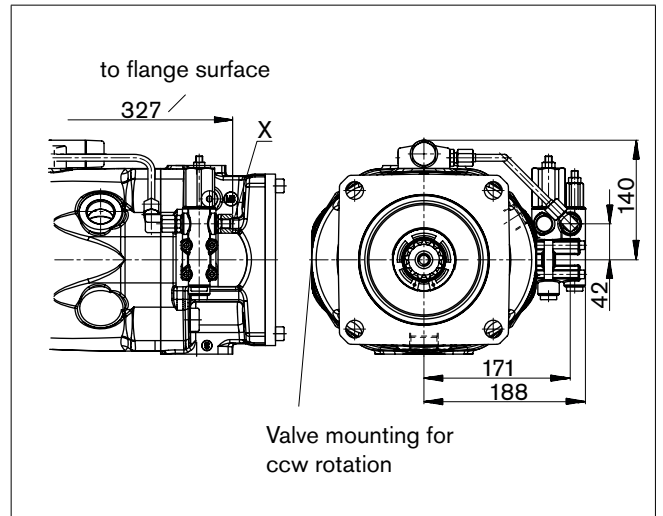

DR

Pressure control

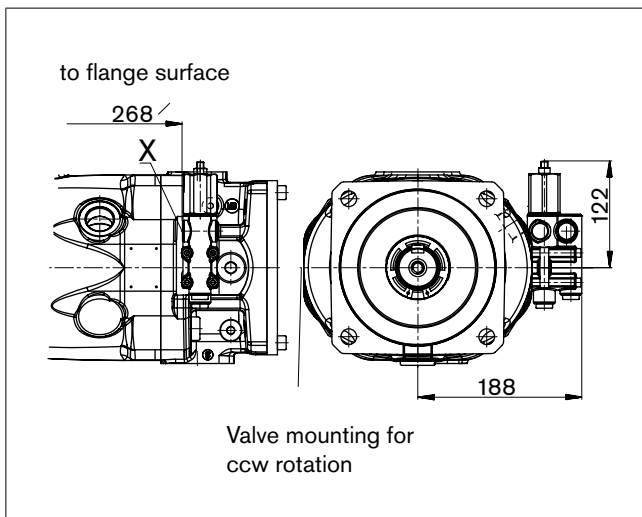

ED7. / ER7.

Electro-hydraulic pressure control

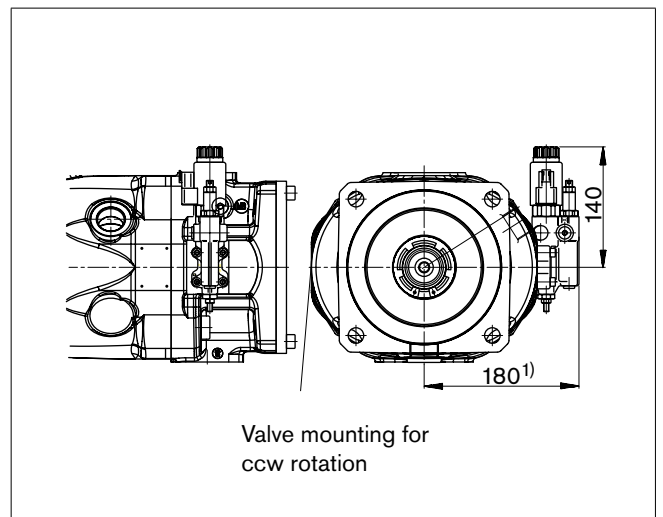

DRG

Pressure, remotely operated

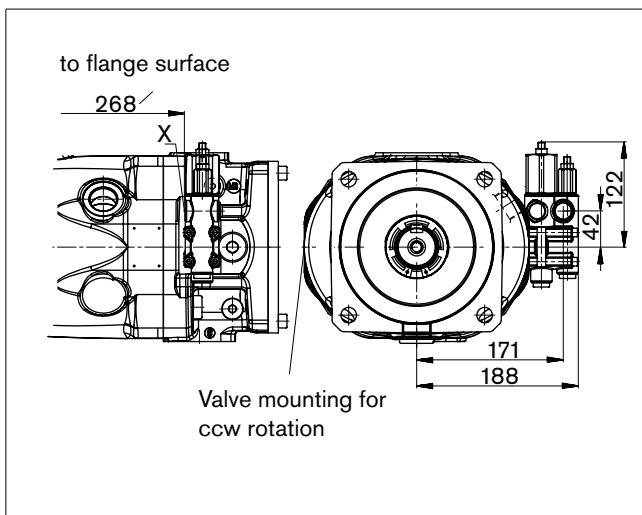

1) ER7.: 215 mm when using a sandwich plate pressure reducing valve.

Dimensions through drive

Before finalizing your design request a certified installation drawing. Dimensions in mm.

K01 flange SAE J744 - 82-2 (A) **Coupling** for splined shaft
5/8in 9T 16/32 DP¹⁾
(SAE J744 - 16-4 (A))

U01 flange SAE J744 - 82-2 (A) **Coupling** for splined shaft
5/8in 9T 16/32 DP¹⁾
(SAE J744 - 16-4 (A))

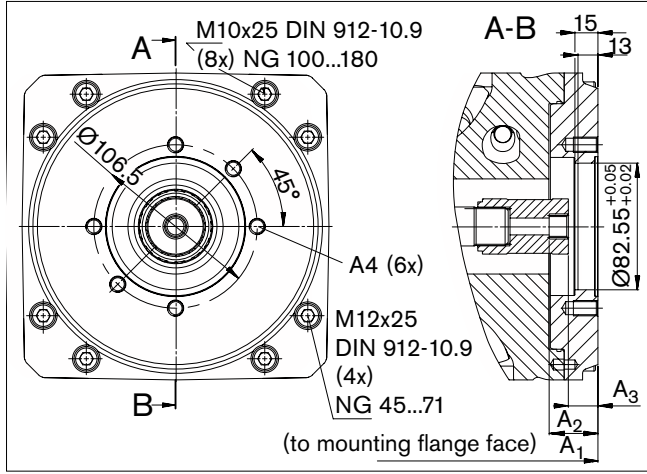
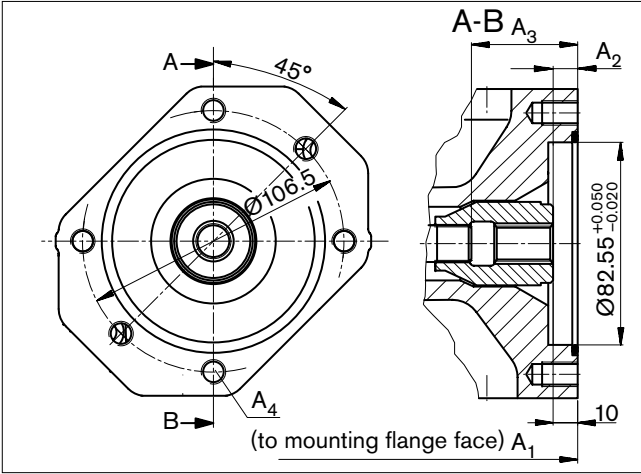

NG	A ₁	A ₂	A ₃	A ₄ ³⁾
71	267	11.8	61.3	M10 x 1.5, 20 deep
100	338	10.5	65	M10 x 1.5, 16 deep
140 ²⁾	350	10.8	77.3	M10 x 1.5, 16 deep

NG	A ₁	A ₂	A ₃	A ₄ ³⁾
180	387	31.8	On request	M10 x 1.5; 16 deep

K52 flange SAE J744 - 82-2 (A) **Coupling** for splined shaft
3/4in 11T 16/32 DP¹⁾
(SAE J744 - 19-4 (A-B))

U52 flange SAE J744 - 82-2 (A) **Coupling** for splined shaft
3/4in 11T 16/32 DP¹⁾
(SAE J744 - 19-4 (A-B))

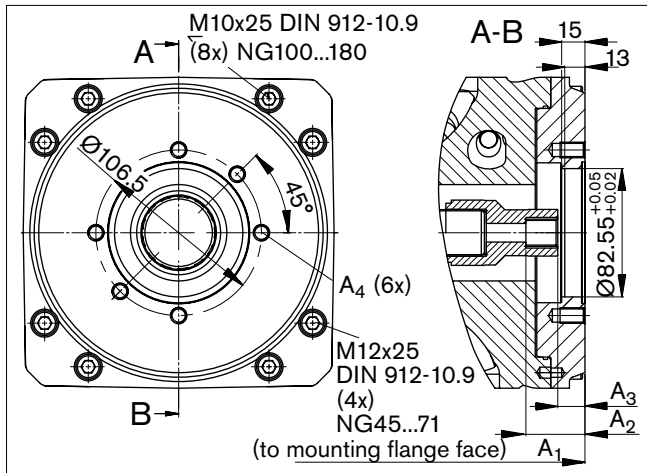
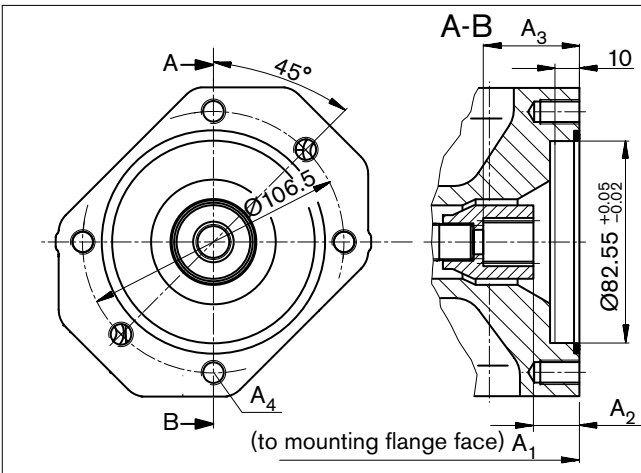

NG	A ₁	A ₂	A ₃	A ₄ ³⁾
71	267	21.3	41.4	M10 x 1.5; 20 deep
100	338	19	38.9	M10 x 1.5; 16 deep
140 ²⁾	350	18.9	38.6	M10 x 1.5; 16 deep

NG	A ₁	A ₂	A ₃	A ₄ ³⁾
180	387	38	17.5	M10 x 1.5; 16 deep

1) 30° pressure angle, flat root, side fit, tolerance class 5 according to ANSI B92.1a-1976
 2) D-flange
 3) Thread according to DIN 13; observe the general instructions on page 44 for the maximum tightening torques.

Dimensions through drive

Before finalizing your design request a certified installation drawing. Dimensions in mm.

K68 flange SAE J744 - 101-2 (B) Coupling for splined shaft 7/8in 13T 16/32 DP¹⁾ (SAE J744 - 22-4 (B))

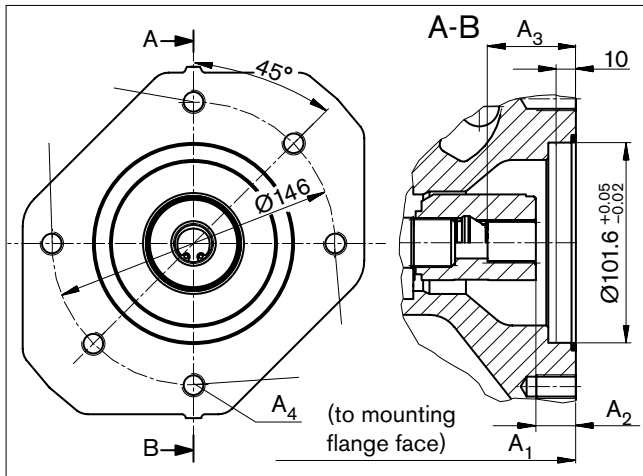

NG	A ₁	A ₂	A ₃	A ₄ ³⁾
71	267	20.3	44.1	M12 x 1.75, 20 deep
100	338	18	41.9	M12 x 1.75, 20 deep
140 ²⁾	350	17.8	41.6	M12 x 1.75, 20 deep

U68 flange SAE J744 - 101-2 (B) Coupling for splined shaft 7/8in 13T 16/32 DP¹⁾ (SAE J744 - 22-4 (B))

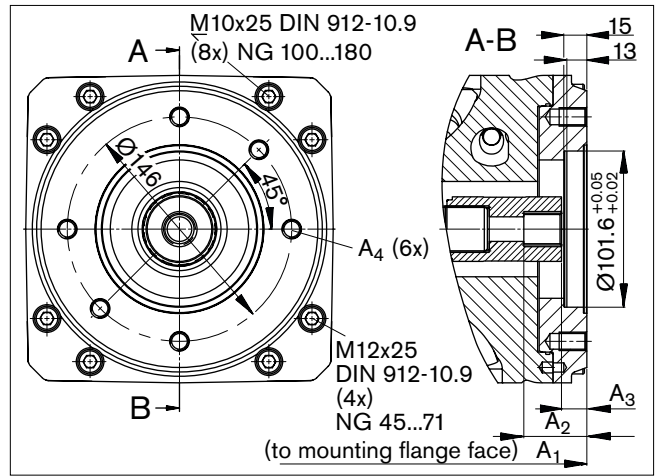

NG	A ₁	A ₂	A ₃	A ₄ ³⁾
180	387	41	16.5	M12 x 1.75; 18 deep

K04 flange SAE J744 - 101-2 (B) Coupling for splined shaft 1in 15T 16/32 DP¹⁾ (SAE J744 - 25-4 (B-B))

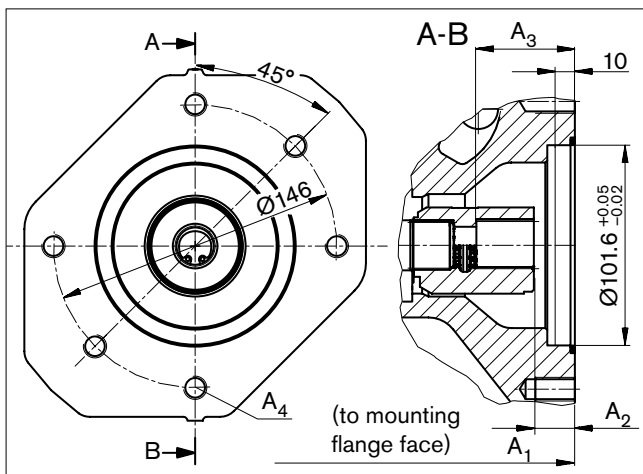

NG	A ₁	A ₂	A ₃	A ₅ ³⁾
71	267	20.8	49.1	M12 x 1.75, 20 deep
100	338	18.2	46.6	M12 x 1.75, 20 deep
140 ²⁾	350	18.3	45.9	M12 x 1.75, 20 deep

U04 flange SAE J744 - 101-2 (B) Coupling for splined shaft 1in 15T 16/32 DP¹⁾ (SAE J744 - 25-4 (B-B))

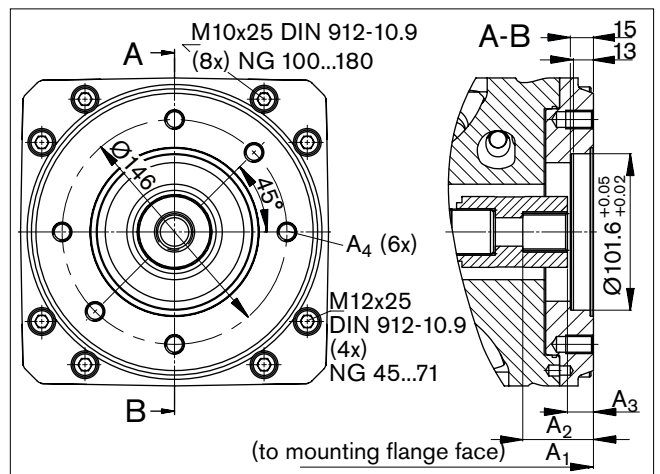

NG	A ₁	A ₂	A ₃	A ₄ ³⁾
180	387	45.9	16.9	M12 x 1.75; 18 deep

1) 30° pressure angle, flat root, side fit, tolerance class 5 according to ANSI B92.1a-1976

2) D-flange

3) Thread according to DIN 13; observe the general instructions on page 44 for the maximum tightening torques.

Dimensions through drive

Before finalizing your design request a certified installation drawing. Dimensions in mm.

K07 flange SAE J744 - 127-2 (C) Coupling for splined shaft 1 1/4 in 14T 12/24 DP¹⁾ (SAE J744 - 32-4 (C))

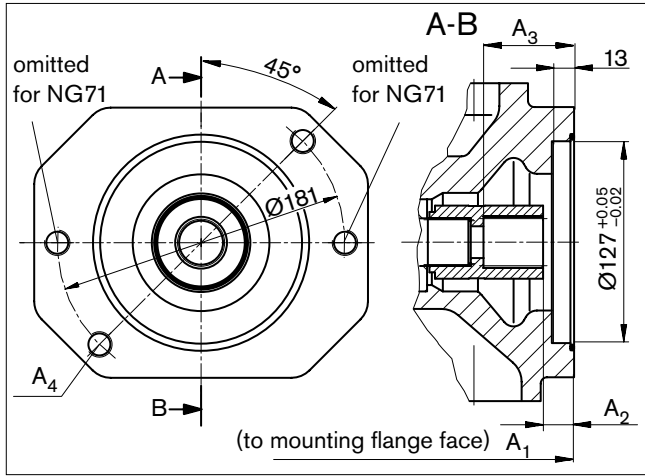

NG	A ₁	A ₂	A ₃	A ₄ ³⁾
71	267	21.8	58.6	M16 x 2, continuous
100	338	19.5	56.4	M16 x 2, continuous
140 ²⁾	350	19.3	56.1	M16 x 2, 24 deep

K24 flange SAE J744 - 127-2 (C) Coupling for splined shaft 1 1/2 in 17T 12/24 DP¹⁾ (SAE J744 - 38-4 (C-C))

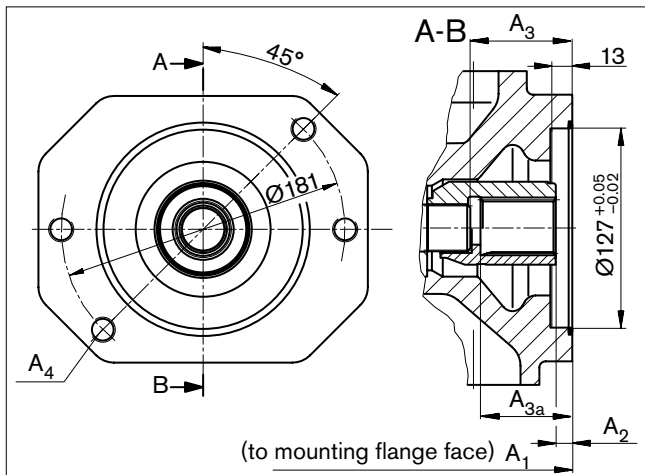

NG	A ₁	A ₂	A ₃ ⁴⁾	A _{3a} ⁵⁾	A ₄ ³⁾
100	338	10.5	65	-	M16 x 2; continuous
140 ²⁾	350	10.8	75	-	M16 x 2; 24 deep
	350	10.3	-	69.1	M16 x 2; 24 deep

U24 flange SAE J744 - 127-2 (C) Coupling for splined shaft 1 1/2 in 17T 12/24 DP¹⁾ (SAE J744 - 38-4 (C-C))

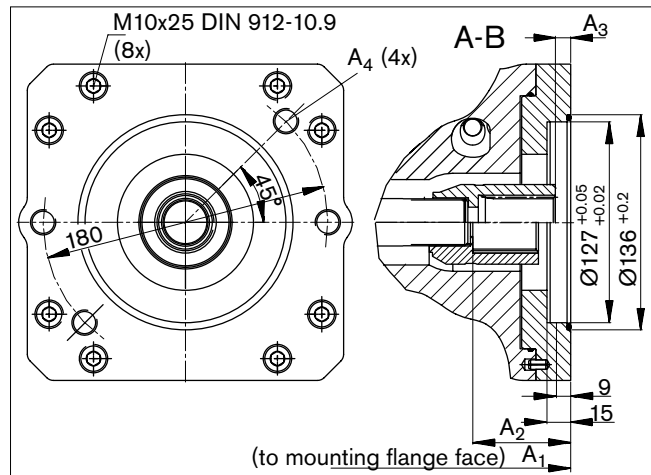

NG	A ₁	A ₂	A ₃	A ₄ ³⁾
180	387	61.9	20.4	M16; 22 deep

1) 30° pressure angle, flat root, side fit, tolerance class 5 according to ANSI B92.1a-1976
 2) D-flange
 3) Thread according to DIN 13; observe the general instructions on page 44 for the maximum tightening torques.
 4) Coupling **without** stop
 5) Coupling **with** stop

Dimensions through drive

Before finalizing your design request a certified installation drawing. Dimensions in mm.

K15 flange SAE J744 - 127-4 (C) Coupling for splined shaft 1 1/4 in 14T 12/24 DP¹⁾ (SAE J744 - 32-4 (C))

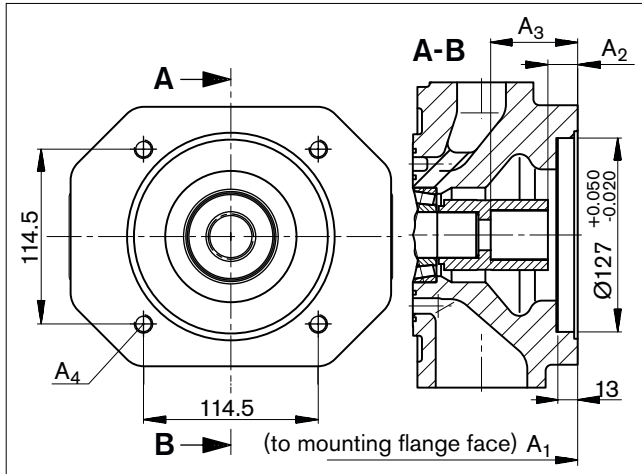

NG	A ₁	A ₂	A ₃	A ₄ ³⁾
100	338	17.9	56.5	M12 x 1.75, 22 deep
140 ²⁾	350	17.9	56.5	M12 x 1.75, 22 deep

U15 flange SAE J744 - 127-4 (C) Coupling for splined shaft 1 1/4 in 14T 12/24 DP¹⁾ (SAE J744 - 32-4 (C))

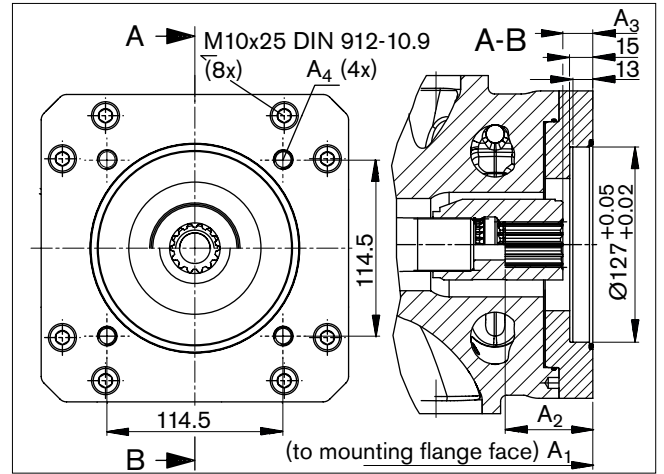

NG	A ₁	A ₂	A ₃	A ₄ ³⁾
180	387	55.4	17.9	M12; 18 deep

K17 flange SAE J744 - 152-4 (D) Coupling for splined shaft 1 3/4 in 13T 8/16 DP¹⁾ (SAE J744 - 44-4 (D))

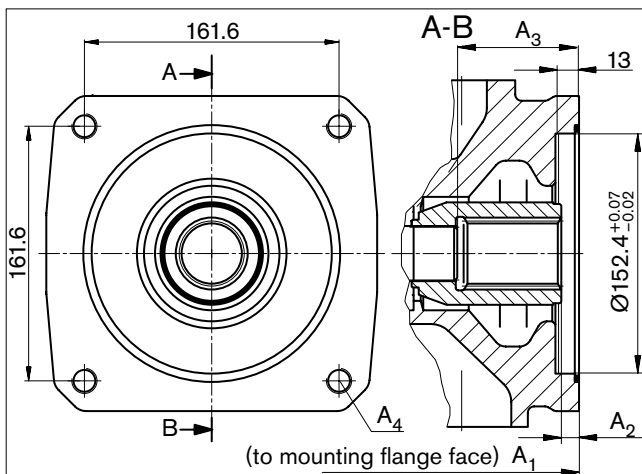

NG	A ₁	A ₂	A ₃	A ₄ ³⁾
140 ²⁾	350	11	77.3	M16 x 2, continuous

U17 flange SAE J744 - 152-4 (D) Coupling for splined shaft 1 3/4 in 13T 8/16 DP¹⁾ (SAE J744 - 44-4 (D))

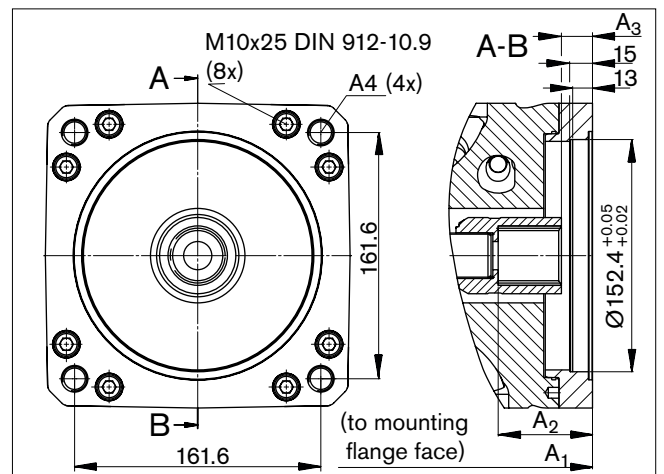

NG	A ₁	A ₂	A ₃	A ₄ ³⁾
180	387	75	On request	M16; 22 deep

1) 30° pressure angle, flat root, side fit, tolerance class 5 according to ANSI B92.1a-1976

2) D-flange

3) Thread according to DIN 13; observe the general instructions on page 44 for the maximum tightening torques.

Overview of attachments

The "U" through drives of the A10VO are equipped with a flexible universal through drive. This enables the utilization of various through drive options without any machining of the port plate. Details of the necessary adapter parts can be found in data sheet RE 95581.

Through drive			Attachment option 2nd pump ¹⁾			Through drive
Flange	Coupling for splined shaft	Code	A10VO/(31)32 NG (shaft)	A10VO/(52)53 NG (shaft)	External gear pump Design (NG)	available for NG
82-2(A)	5/8 in	(K)(U)01		(10) (U); 18 (U)	F (5 to 22)	71 to 180
	3/4 in	(K)(U)52		(10) (S); 18 (S, R)	F (5 to 22)	
101-2(B)	7/8 in	(K)(U)68	(28) (S, R)	28 (S, R)	N/G (26 to 49)	71 to 180
	1 in	(K)(U)04	(45) (S, R)	(45) (S, R)	–	
127-2(C)	1 1/4 in	(K)(U)07	71 (S, R)	85 (U, W)	–	71 to 180
	1 1/2 in	(K)(U)24	100 (S, R)	85 (S)	–	100 to 180
127-4(C)	1 1/4 in	(K)(U)15	71 (S, R)	63 (S, R)	–	71 to 180
152-4(D)	1 3/4 in	(K)(U)17	140 (S)	–	–	140 to 180

¹⁾ 2nd attachment pump sizes 71 to 100 only with mounting flange C, sizes 140 to 180 with mounting flange D

Combination pumps A10VO + A10VO

When using combination pumps it is possible to have multiple, mutually independent circuits without the need for a splitter gearbox.

When ordering combination pumps, the model codes for the 1st and the 2nd pump must be joined by a "+".

Order example :
A10VO100DR/32R-VSC12K07 +
A10VO71DR/32R-VSC12N00

If a gear pump or radial piston pump is to be factory-mounted, please contact us.

The A10V(S)O axial piston unit can be delivered with a through drive, as shown in the type code on page 3.

The through-drive version is determined by the code ((K)(U)01-(K) (U)24). If no further pumps are to be factory-mounted, the simple type code is sufficient.

The delivery contents of the pump with through drive include: coupling, seal and, if necessary, an intermediate flange.

Each through drive with port plate 12 is plugged with a **non-pressure-resistant** cover. Before commissioning the units, they must therefore be equipped with a pressure-resistant cover.

Through drives can also be ordered with pressure-resistant covers. Please specify in clear text.

Permissible mass moment of inertia

It is permissible to use a combination of two single pumps of the same size (tandem pump), considering a dynamic mass acceleration of maximum 10 g (=98.1 m/s²) without additional support bracket

NG		71	100	140	180	
Permissible mass torque with 4-hole flange	static	T_m Nm	3000	4500	4500	4500
	dynamic at 10 g (98.1m/s ²)	T_m Nm	300	450	450	450
Permissible mass torque with 2-hole flange	static	T_m Nm	2160	3000	3000 ¹⁾	-
	dynamic at 10 g (98.1m/s ²)	T_m Nm	216	300	300 ¹⁾	-
Mass (12N00) approx.	m_1 kg	36.5	55	70	-	
Mass (22U00) approx.	m_1 kg	47	69	73	78	
Distance center of gravity	l_1 mm	142	169	172	196	

1) Pump combination permissible only max. as double pump of same size.

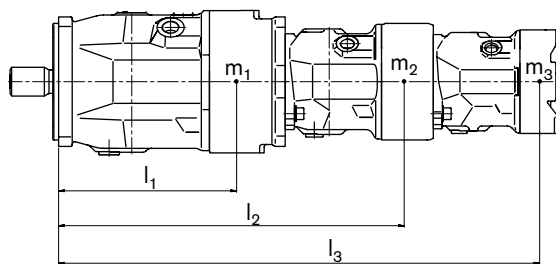

m_1, m_2, m_3 Weight of pumps [kg]

l_1, l_2, l_3 Distance center of gravity [mm]

$$T_m = (m_1 \cdot l_1 + m_2 \cdot l_2 + m_3 \cdot l_3) \cdot \frac{1}{102} \text{ [Nm]}$$

Connector for solenoids

Before finalizing your design request a certified installation drawing. Dimensions in mm.

DEUTSCH DT04-2P-EP04, 2-pin

Molded, without bidirectional suppressor diode _____ P

The following type of protection is provided with installed mating connector:

IP67 and IP69K
DIN/EN 60529
DIN 40050-9

Circuit symbol

Without bidirectional suppressor diode

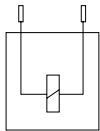

Mating connector

DEUTSCH DT06-2S-EP04
Bosch Rexroth Mat. No. R902601804

Consisting of: DT designation
 – 1 case _____ DT06-2S-EP04
 – 1 wedge _____ W2S
 – 2 sockets _____ 0462-201-16141

The mating connector is not included in the delivery contents. This can be supplied by Bosch Rexroth on request.

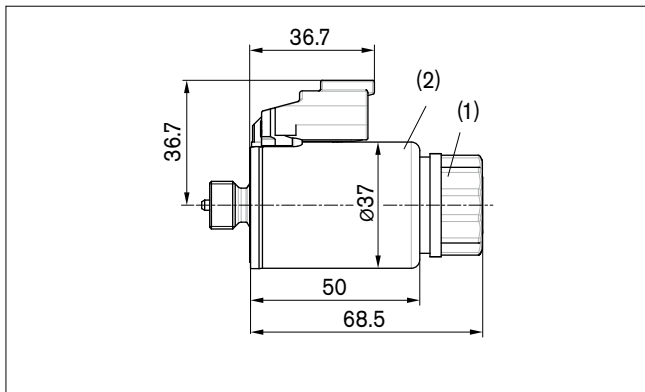

Changing connector position

If necessary, you can change the position of the connector by turning the solenoid.

To do this, proceed as follows:

1. Loosen the mounting nut (1) of the solenoid. To do this, turn the mounting nut (1) one revolution counter-clockwise.
2. Turn the solenoid body (2) to the desired position.
3. Retighten the mounting nut of the solenoid. Tightening torque: 5+1 Nm (size WAF 26, 12-pt DIN 3124).

On delivery, the position of the connector may differ from that shown in the brochure or drawing.

Electronic controls

Control	Electronics function	Electronics		Further information
Electric pressure control	Controlled power outlet	RA	analog	RE 95230
		RC2-2/21 ¹⁾	digital	RE 95201

¹⁾ Power outlets for 2 valves, can be actuated separately

²⁾ Only 24V nominal voltage

³⁾

For further information on mobile electronics, see www.boschrexroth.de/mobile-electronics

Notes

Installation instructions

General

The axial piston unit must be filled with hydraulic fluid and air bled during commissioning and operation. This must also be observed following a longer standstill as the axial piston unit empty via the hydraulic lines.

Particularly with the "drive shaft up/down" installation position, filling and air bleeding must be carried out completely as there is, for example, a danger of dry running.

The case drain fluid in the motor housing must be directed to the reservoir via the highest case drain port (L_1 , L_2 , L_3).

For combinations of multiple units, make sure that the respective case pressure in each unit is not exceeded. In the event of pressure differences at the drain ports of the units, the shared drain line must be changed so that the minimum permissible case pressure of all connected units is not exceeded in any situation. If this is not possible, separate drain lines must be laid if necessary.

To achieve favorable noise values, decouple all connecting lines using elastic elements and avoid above-reservoir installation.

In all operating conditions, the suction line and case drain line must flow into the reservoir below the minimum fluid level. The permissible suction height h_S is a result of the overall pressure loss, but may not be greater than $h_{S \max} = 800$ mm. The minimum suction pressure at port S must also not fall below 0.8 bar absolute during operation.

Installation position

See the following examples 1 to 12.

Additional installation positions are available upon request.

Recommended installation positions: 1 and 3.

Note

- You can expect certain installation positions to affect the control device. Because of gravity, unit weight and case pressure, minor characteristic displacements and response time changes may occur.

Below-reservoir installation (standard)

Below-reservoir installation means the axial piston unit is installed outside of the reservoir below the minimum fluid level.

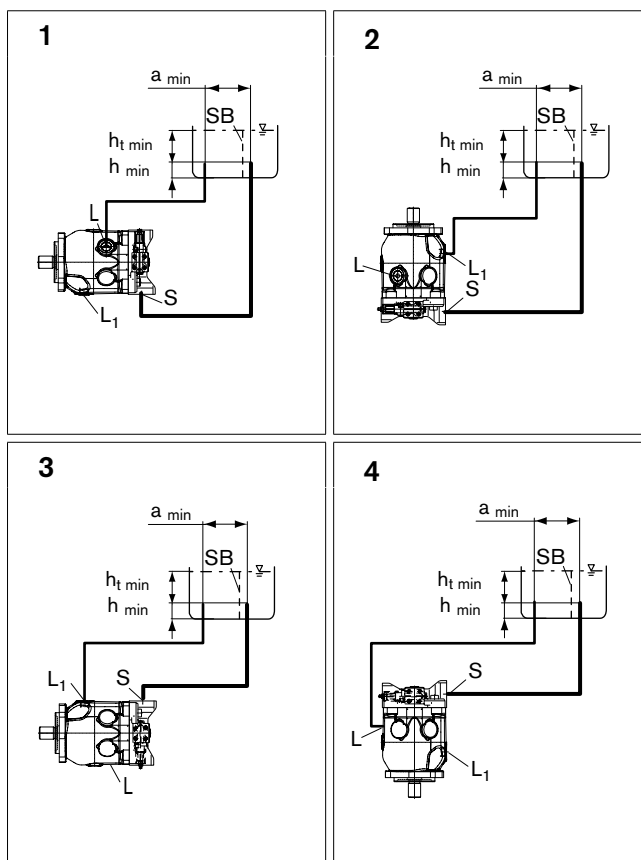

Installation position	Air bleed	Filling
1	L	S + L
2	L_1	S + L_1
3	L_1	S + L_1
4	L	S + L

Installation instructions

Above-reservoir installation

Above-reservoir installation means the axial piston unit is installed above the minimum fluid level of the reservoir.

To prevent the axial piston unit from draining, a height difference $h_{ES\ min}$ of at least 25 mm is required in installation position 6

Observe the maximum permissible suction height $h_{S\ max} = 800\ mm$.

A check valve in the case drain line is only permissible in individual cases. Consult us for approval.

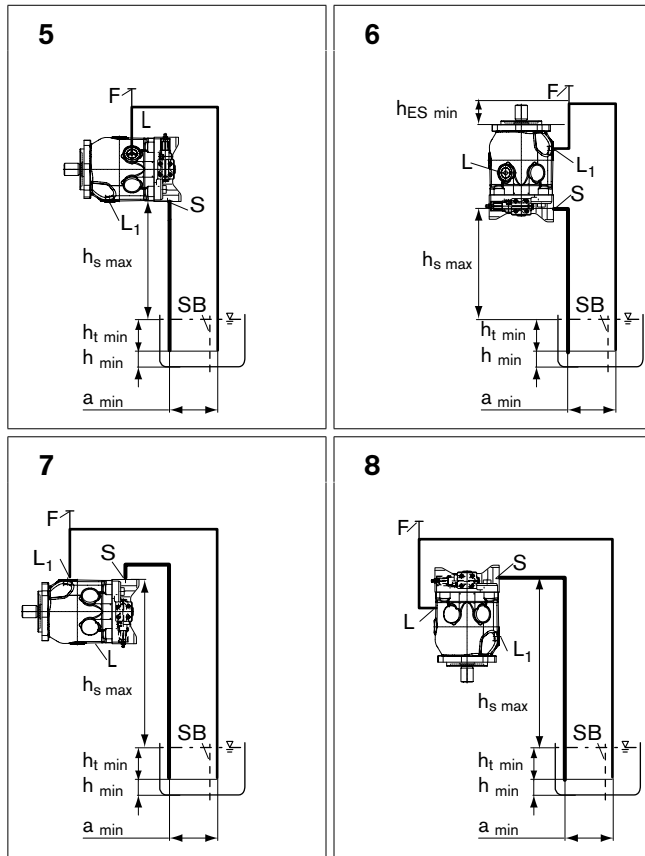

Installation position	Air bleed	Filling
5	F	L (F)
6	F	L ₁ (F)
7	F	S + L ₁ (F)
8	F	S + L (F)

Inside-reservoir installation

Inside-reservoir installation means the pump is installed within the minimum reservoir fluid level.

Axial piston units with electrical components (e.g. electric control, sensors) may not be installed in a reservoir below the fluid level.

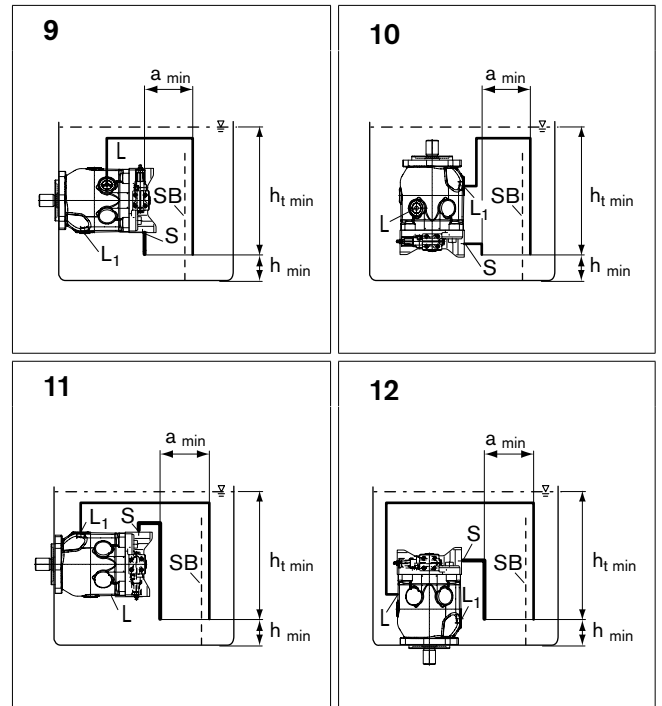

Installation position	Air bleed	Filling
9	L	L
10	L ₁	L ₁
11	L ₁	S + L ₁
12	L	S + L

- S** Suction port
- F** Filling / air bleeding
- L, L₁** Case drain port
- SB** Baffle (baffle plate)
- h_{t min}** Minimum necessary immersion depth (200 mm)
- h_{min}** Minimum necessary spacing to reservoir bottom (100 mm)
- h_{ES min}** Minimum necessary height needed to protect the axial piston unit from draining (25 mm).
- h_{S max}** Maximum permissible suction height (800 mm)
- a_{min}** When designing the reservoir, ensure adequate distance between the suction line and the case drain line. This prevents the heated, return flow from being drawn directly back into the suction line.

General instructions

- The A10VO pump is designed to be used in open circuit.
- Project planning, installation and commissioning of the axial piston unit require the involvement of qualified personnel.
- Before operating the axial piston unit, please read the appropriate instruction manual thoroughly and completely. If necessary, request these from Bosch Rexroth.
- During and shortly after operation, there is a risk of burns on the axial piston unit and especially on the solenoids. Take appropriate safety measures (e.g. by wearing protective clothing).
- Depending on the operating conditions of the axial piston unit (operating pressure, fluid temperature), the characteristics may shift.
- Service line ports:
 - The ports and fastening threads are designed for the specified maximum pressure. The machine or system manufacturer must ensure that the connecting elements and lines correspond to the specified application conditions (pressure, flow, hydraulic fluid, temperature) with the necessary safety factors.
 - The service line ports and function ports are only designed to accommodate hydraulic lines.
- Pressure cut-off and pressure control do not provide security against pressure overload. A separate pressure relief valve is to be provided in the hydraulic system.
- The data and notes contained herein must be adhered to.
- The product is not approved as a component for the safety concept of a general machine according to ISO 13849.
- The following tightening torques apply:
 - Fittings:
Observe the manufacturer's instruction regarding the tightening torques of the used fittings.
 - Mounting bolts:
For mounting bolts with metric ISO thread according to DIN 13 or thread according to ASME B1.1, we recommend checking the tightening torque individually according to VDI 2230.
 - Female threads in axial piston unit:
The maximum permissible tightening torques $M_{G \max}$ are maximum values for the female threads and must not be exceeded. For values, see the following table.
 - Threaded plugs:
For the metal threaded plugs supplied with the axial piston unit, the required tightening torques of the threaded plugs M_V apply. For values, see the following table.

Ports		Maximum permissible tightening torque for female threads $M_{G \max}$	Required tightening torque for threaded plugs M_V	Size of hexagon socket of threaded plugs
Standard	Thread size			
DIN 3852	G1/4	70 Nm	–	–
DIN ISO 228	G1/4	70 Nm	30 Nm	6 mm
ISO 11926	7/16-20UNF-2B	40 Nm	18 Nm	3/16 in
	9/16-18UNF-2B	80 Nm	35 Nm	1/4 in
	3/4-16UNF-2B	160 Nm	70 Nm	5/16 in
	7/8-14UNF-2B	240 Nm	110 Nm	3/8 in
	1 1/16-12UN-2B	360 Nm	170 Nm	9/16 in
	1 5/16-12 UN-2B	540 Nm	270 Nm	5/8 in