

Pressure cut-off valve, pilot operated

RE 26411/08.10
Replaces: 02.03

1/22

Type DA and DAW

Sizes 10 to 32
 Component series 5X
 Maximum operating pressure 315 bar
 Maximum flow 400 l/min



H7661

Table of contents

Contents	Page
Features	1
Ordering code	2, 3
Mating connectors	3
Symbols	4
Function, section	5 to 8
Technical data	8, 9
Characteristic curves	10 to 12
Unit dimensions	13 to 20
Installation bore	19
Circuit examples	21

Features

- For subplate mounting
- As installation valve
- 4 adjustment types, optionally:
 - Rotary knob
 - Adjustment spindle with protective cap
 - Lockable rotary knob with scale
 - Rotary knob with scale
- 4 pressure ratings
- Solenoid operated unloading via a built-on directional spool valve
- More information:

High-power directional valves	Data sheet 23178
Subplates	Data sheet 45062

Information on available spare parts:
www.boschrexroth.com/spc

Symbols: Type DA. (without directional valve)

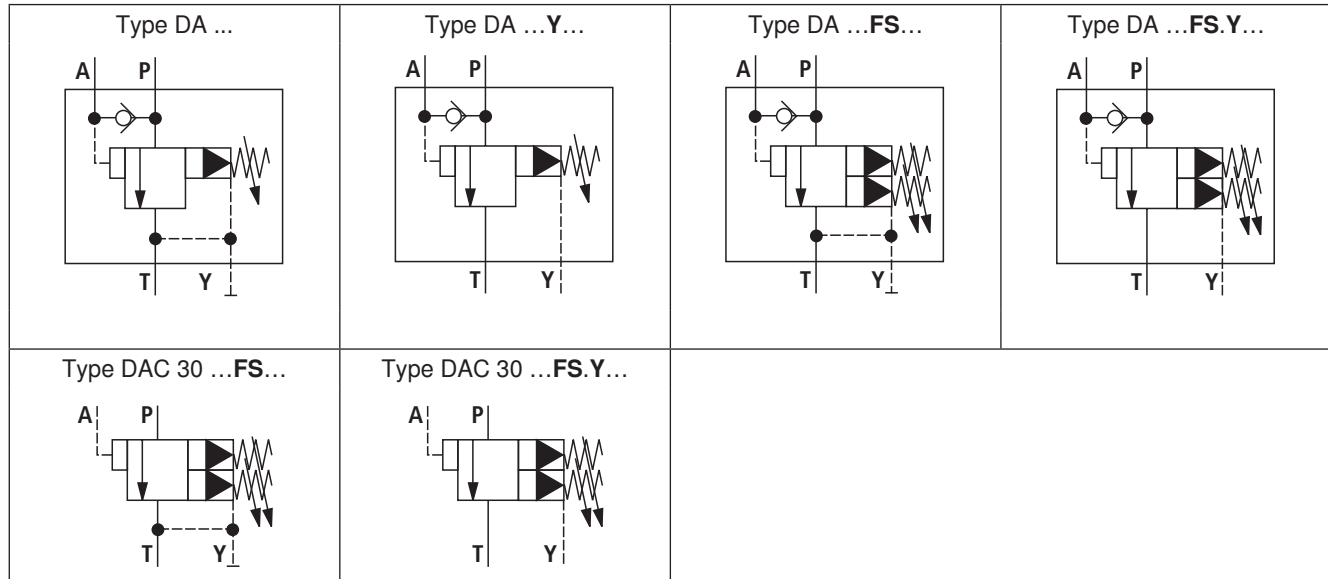

Symbols: Type DAW (with built-on directional valve)

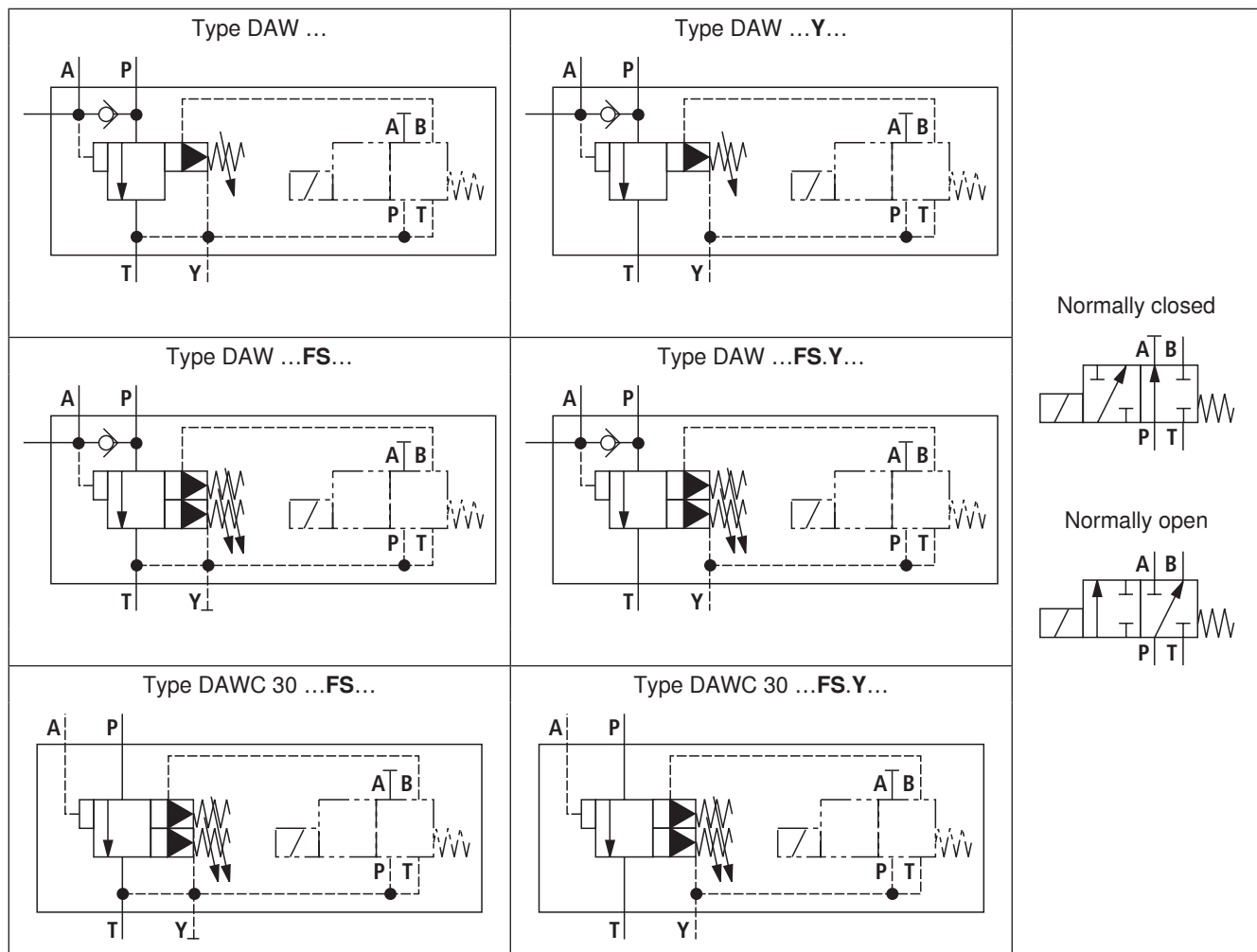

Function, section: Type DA...FS... (freely adjustable switching pressure differential)

The pressure valve type DA is a pilot operated pressure cut-off valve. It is used for example in accumulator charging circuits. In this application an accumulator is filled until the accumulated charging pressure is reached. When the accumulator pressure is reached the valve switches the displacement in depressurized circulation until the pressure in the hydraulic system has dropped by the switching pressure differential. Then the charging process is started again.

The pressure cut-off valve basically comprises of main housing (1), pilot control valve (2 and 3), main spool insert (4) and check valve (7).

- Diverting the pump flow from 'P to A' to 'P to T'.

The pump displaces via the check valve (7) into the hydraulic system (P to A). The pressure applied to channel A acts via the control line (8) on the control piston in the pilot control valve (3). At the same time pressure is applied in channel P via the nozzle (5) on the spring loaded side of the main spool (4) and via the control line (9) at the input (11) of the cartridge valve (3). As soon as the upper cut-off pressure that was set at the cartridge valve (3) by means of the adjustment spindle (12) is reached in the hydraulic system the cartridge valve will internally open the connection of the spring loaded side of the main spool (4) towards the return line (10) after T (Type DA ...) or externally via the port Y (Type DA ... Y).

Due to the nozzle (5) a pressure drop occurs at the main spool (4). The spool then lifts from its seat and opens the connection P to T. The check valve (7) closes the P to A

connection. The actuator pressure A fixes the cartridge valve (3) in opened position.

- Diverting the pump flow from 'P to T' to 'P to A'.

If the actuator pressure A has dropped to the pressure value set at the adjustment spindle (14), the cartridge valve (3) switches to the initial position and closes the connection between the spring loaded side of the main spool (4) and the return line (10). Consequently, the pressure on the spring loaded side of the main spool (4) increases and causes the closing of the P to T connection by means of the compression spring (6). The pump now again displaces via the check valve (7) into the hydraulic system (P to A).

Version "FSB07"

With this valve an nozzle used for damping a possible switching shock is integrated in the control line (11). This inevitably leads to an increased circulation pressure (P to T), see characteristic curves, page 10.

Notes!

- **Indirect pressure relief function only:**

A pressure relief function for the pump pressure (towards the tank) is not available directly but only indirectly via check valve (7), control line (8) and pilot control valve (2) towards channel T.

- **Adjustment of the switching pressure differential**

In the factory the valves are set to a switching pressure differential of approx. 10 % to 12 % at nominal pressure. Adjustment of up to 50 % of the nominal pressure is possible.

The unit is delivered with the adjustment spindle turned out and set to the minimum adjustable upper switching pressure. The upper switching pressure can be increased by turning the adjustment spindle (12) in.

Adjustment spindle (14) is used for changing the switching pressure differential: Turn out - decrease, turn in - increase.

The pressure adjustments are secured by means of the clamping screw (13) and the lock nut (15).

- Depending on the system conditions (in particular for high pump and actuator flow) switching pressure values may be higher than illustrated in the characteristic curves. For such cases the valve provides the possibility of ideally adapt the switching pressure differential to the system.

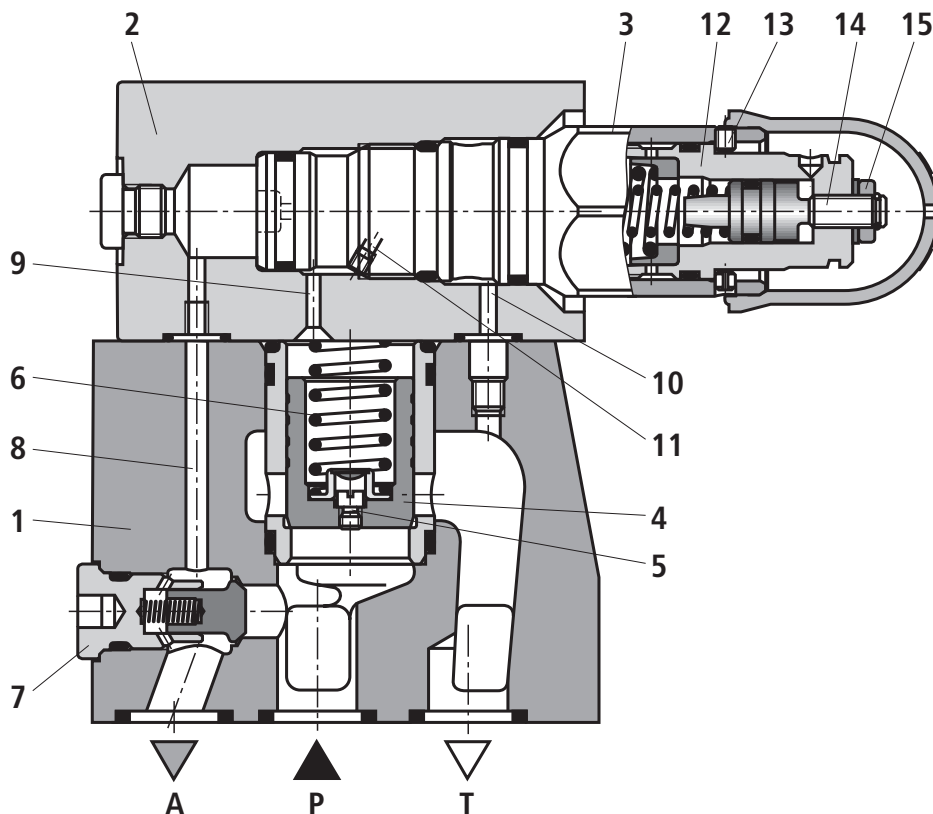

Type DA 10 -2-5X/.FS...

Function, section: Type DA... (fixed settings for switching pressure differential of 10 % or 17 %)

The function of this valve corresponds to the function of the "FS" version. However, with the pilot control valve only the upper switching pressure and not the switching pressure differential can be adjusted.

The area of the pilot spool (16) can optionally be selected to be 10 % or 17 % larger than the effective area of the ball (17). Consequently, the effective force at the pilot spool (16) is also 10 % or 17 % higher than the effective force at the ball (17).

- Diverting the pump flow from 'P to A' to 'P to T'.

Pressure is applied in channel P via the nozzles (5 and 9) on the spring loaded side of the main spool (4) and at the ball (17) in the pilot control valve (2). As soon as the cut-off pressure that is set by means of the adjustment spindle (12) is reached in the hydraulic system the ball (17) opens against the spring (18). Then the hydraulic fluid flows via the nozzles (5 and 9) into the spring chamber (19) into the return line (10) towards T (Type DA ...) or externally via port Y (Type DA ...Y). The main spool (4) is lifted from its seat and opens the P to T connection. The check valve (7) closes the P to A connection. The actuator pressure A retains the ball in the pilot control valve (2) in open position via the pilot spool (16).

- Diverting the pump flow from 'P to T' to 'P to A'.

If actuator pressure A has decreased by the switching pressure differential of 10 % or 17 % relative to the set cut-off pressure (acc. to characteristic curve, page 11), the spring (18) in the pilot control valve (2) closes the ball (17). Consequently, the pressure on the spring loaded side of the main spool (4) increases and causes the closing of the P to T connection by means of the compression spring (6). The pump now again displaces via the check valve (7) into the hydraulic system (P to A).

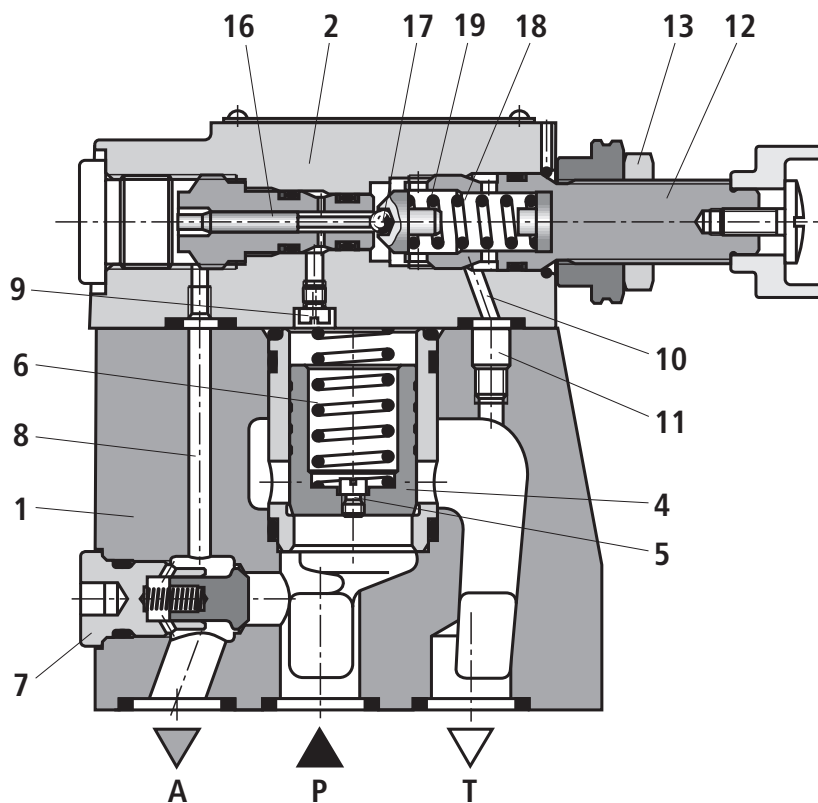

Type DA 10 -1-5X/...

Function, section: Type DAW...

The function of this valve corresponds to the function of valve Type DA However, for pressure values lower than the set cut-off pressure with this valve it is possible to optionally divert flow to P to T or P to A by means of the solenoid operated directional spool valve (20).

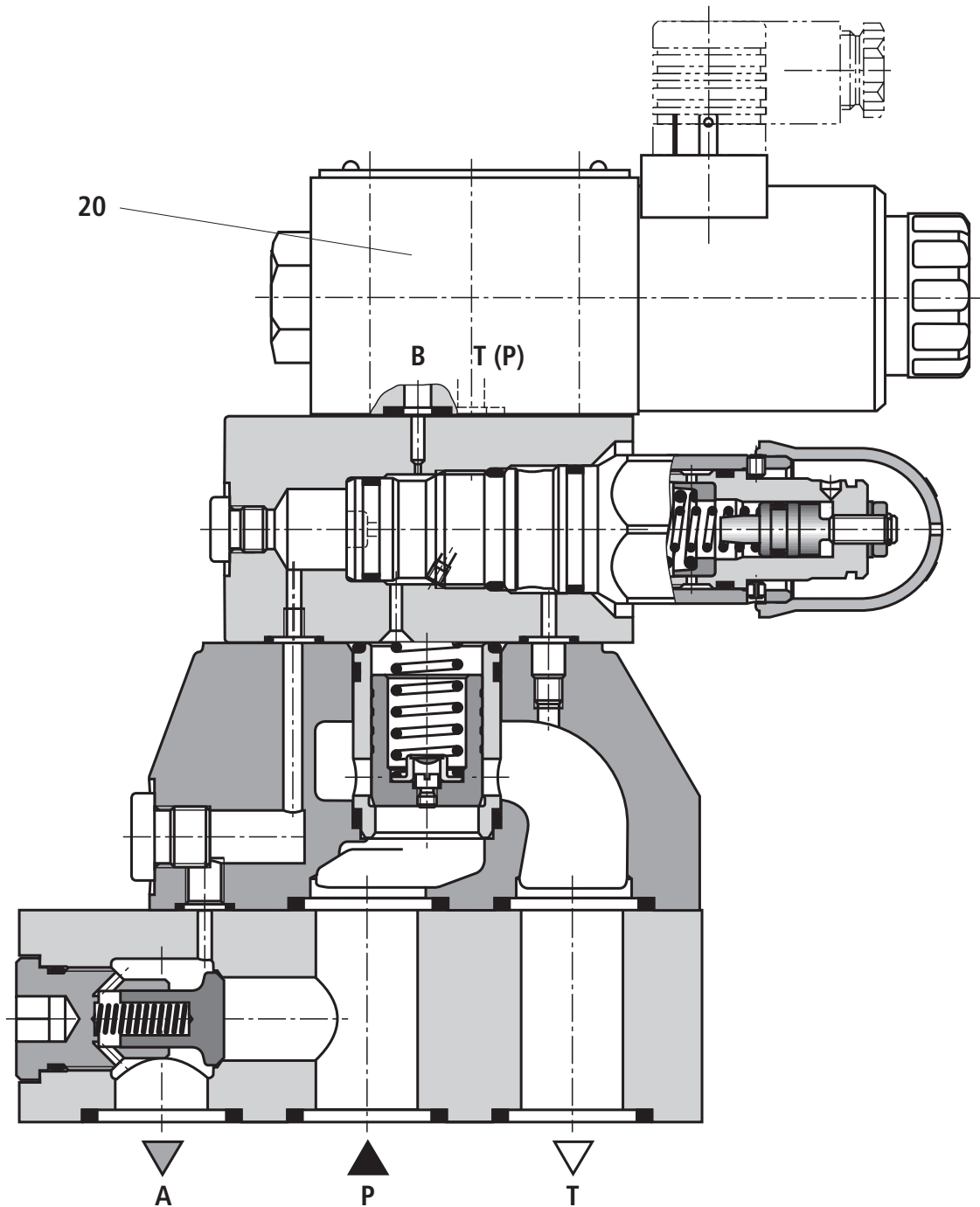

Type DAW 20 -1-5X/...6E..K4...

Function, section: Type DA(W)C...

Pressure cut-off valve Type DA(W)C 30 ...FS...

This valve comprises pilot control housing (2), cartridge valve (3) as pilot control unit and a main spool insert (4).

Pressure cut-off valve Type DA(W)C ...10/17...

This valve comprises pilot control valve (2), and optionally a main spool insert (4).

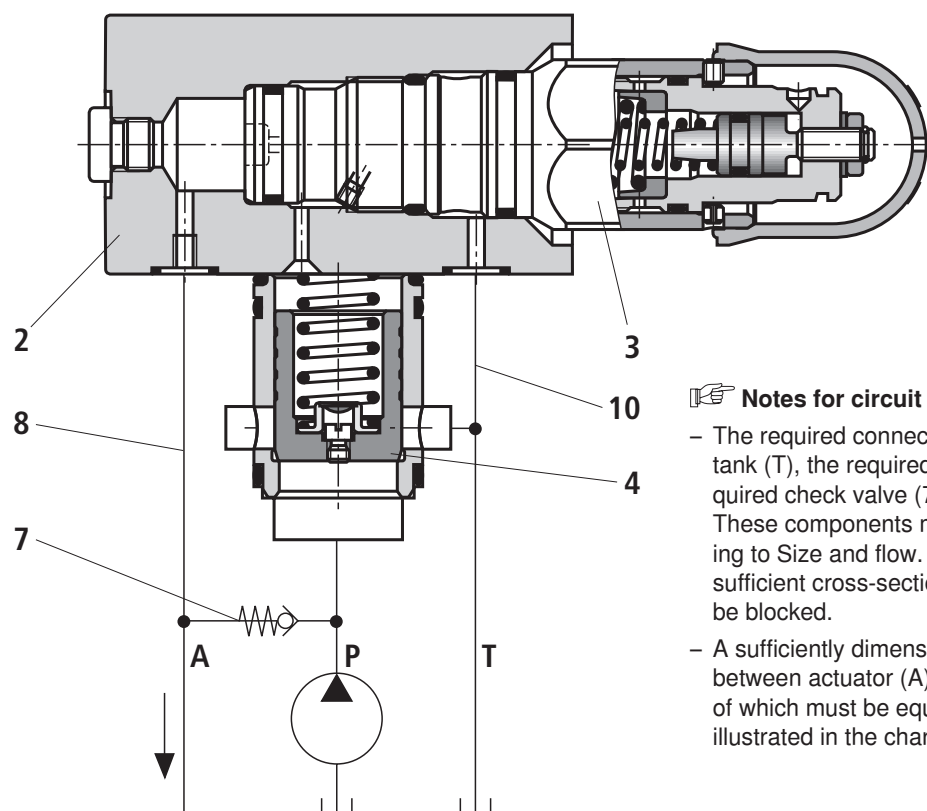

Notes for circuit configuration with Type DAC...

- The required connections for actuator (A), pump (P), and tank (T), the required control lines (8) and (10), and the required check valve (7) are not included in scope of delivery. These components must be appropriately designed according to Size and flow. Connections must be designed with a sufficient cross-section and arranged such that they cannot be blocked.
- A sufficiently dimensioned check valve must be integrated between actuator (A) and pump (P) the flow characteristics of which must be equal to or better than the characteristics illustrated in the characteristic curves on page 12.

Technical Data (For applications outside these parameters, please consult us!)

general					
Size		Size	10	25	32
Weight	- Type DA ...	kg	3.8	7.7	13.5
	- Type DA ...FS	kg	4.4	8.3	14.1
	- Type DAW ...	kg	5.3	9.2	15.0
	- Type DAW ...FS	kg	5.8	9.8	15.6
	- Type DAC ...	kg	1.2		
	- Type DAWC ...	kg	2.4		
	- Type DAC 30 ...	kg	1.4		
	- Type DAC 30 ...FS	kg	1.9		
	- Type DAWC 30 ...	kg	2.9		
	- Type DAC 30 ...FS	kg	3.4		
Installation position			Any		
Ambient temperature range	- Type DA ...	°C	-30 to +80 (NBR seals) -20 to +80 (FKM seals)		
	- Type DAW ...		-30 to +50 (NBR seals) -20 to +50 (FKM seals)		

Technical Data (For applications outside these parameters, please consult us!)

hydraulic		Size	10	25	32
Maximum operating pressure	– Port P	bar	315		
	– Port A	bar	315 (after diverting P to T)		
	– Port T, Y	bar	100 ^{1; 4)}		
Setting pressure range ²⁾	– Pressure rating 50	bar	25 to 50		
	– Pressure rating 100		50 to 100		
	– Pressure rating 200		100 to 200		
	– Pressure rating 315		200 to 315 (Type DA...FS... 150 to 315)		
Switching pressure differential ²⁾	– Version "FS"	%	Freely adjustable (10 % to 50 % of the nominal setting pressure)		
	– Version "10"	%	10		
	– Version "17"	%	17		
Maximum flow	– Version "FS"	l/min	120	250	400
	– Version "10"	l/min	40	80	120
	– Version "17"	l/min	60	120	240
Hydraulic fluid		Mineral oil (HL, HLP) according to DIN 51524; other hydraulic fluids upon request			
Hydraulic fluid temperature range	°C	–30 to +80 (NBR seals) –20 to +80 (FKM seals)			
Viscosity range	– Maximum	mm ² /s	10 to 800		
	– Recommended	mm ² /s	20 to 60		
Maximum permitted degree of contamination of the hydraulic fluid - cleanliness class according to ISO 4406 (c)		Class 20/18/15 ³⁾			

1) Attention!

The applied pressure is added to the setting pressure! The switching pressure differential remains unchanged within the setting range!

2) The following points must be observed for setting of the switching pressure differential:

- The upper and lower switching point must be within the setting range of the pressure rating (e.g. pressure rating 100 bar: Upper switching point 100 bar, lower switching point 50 bar corresponds to a switching pressure differential of 50 %)
- Basically the lowest possible switching pressure differential value depends on the system (i.e. set pressure, pump and actuator flow, size and preload of accumulator, length of line and line resistance before and after the valve, etc.). The valve provides a possibility of ideally adapting the switching pressure differential to the system conditions. However, the lowest switching pressure differential value of the valve cannot always be realized in a system due to above-stated reasons.
- The connection between pressure cut-off valve and hydraulic accumulator must generally be in the form of short and low-resistance connection tubing and the pilot oil (version "Y", if required) must be drained at zero pressure.
- For notes on factory settings of the switching pressure differential, see page 5.

3) The cleanliness classes specified for the components must be adhered to in hydraulic systems. Effective filtration prevents faults and at the same time increases the service life of the components.

For the selection of the filters see www.boschrexroth.com/filter.

4) The tank pressure must not be higher than the pump pressure.

Characteristic curves (measured with HLP46, $\vartheta_{oil} = 40 \pm 5 \text{ }^\circ\text{C}$)

Circulation pressure depending on flow q_{VP} and chushingion (P → T)

Size 10

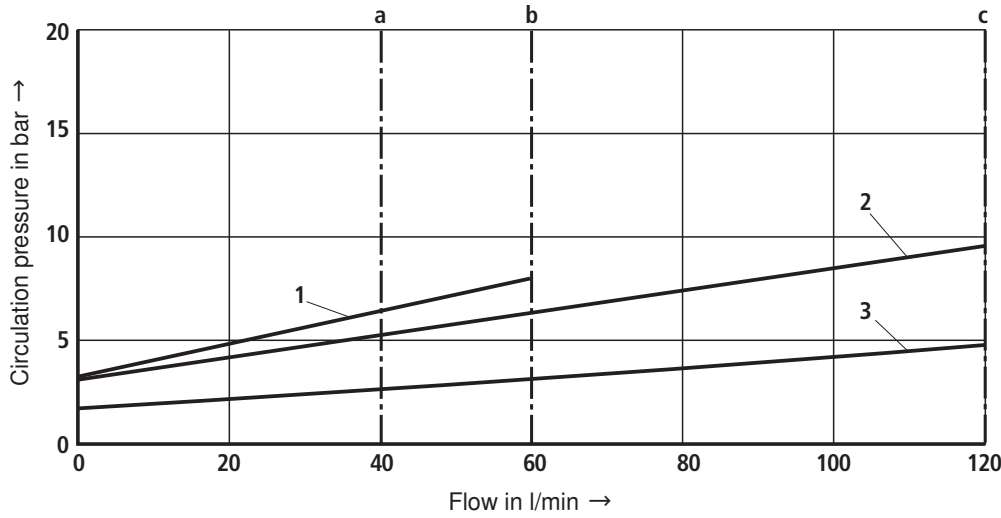

Size 25

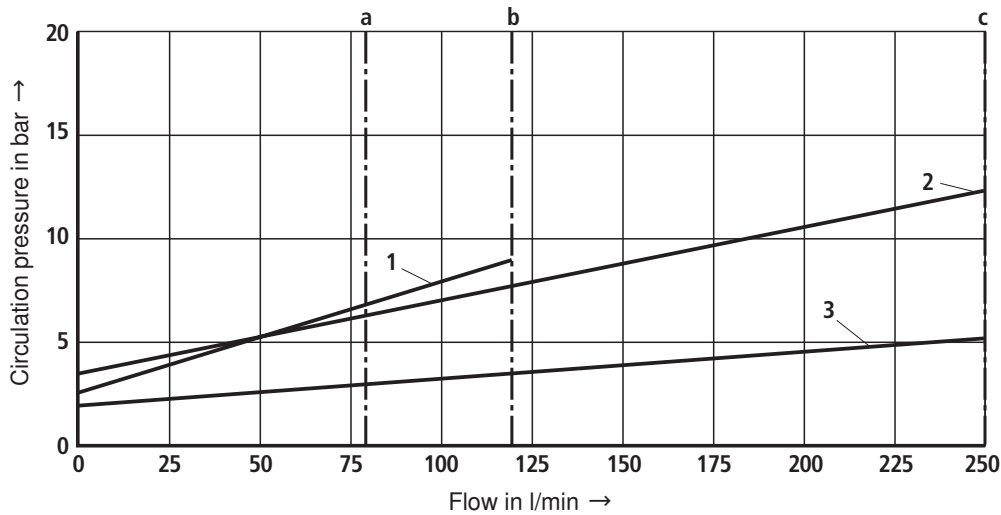

Size 32

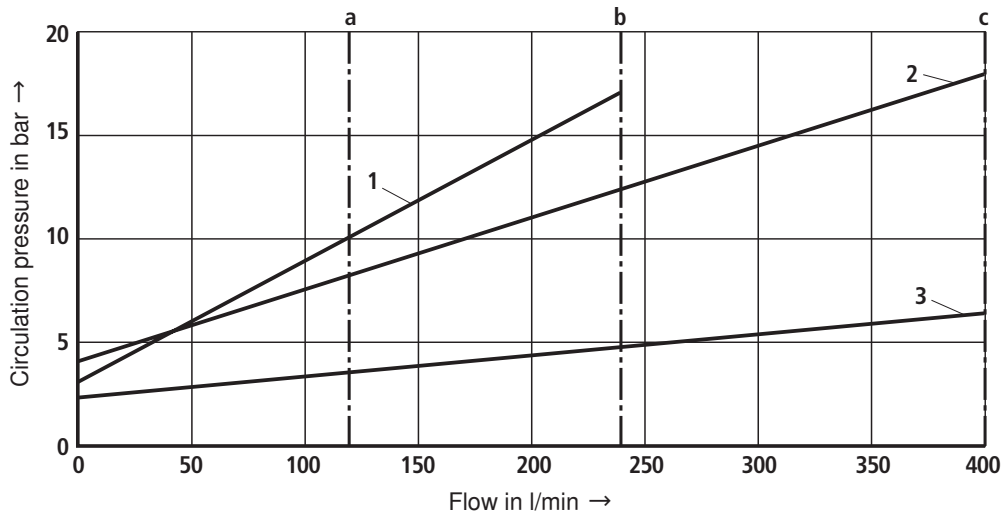

a $q_{VP \max}$ version "10"

b $q_{VP \max}$ version "17"

c $q_{VP \max}$ version "FS"

1 Type DA ...

2 Type DA ...FSB07...

3 Type DAW ...FS...

Note!

Flow depends on the set switching pressure differential.

Characteristic curves (measured with HLP46, $\vartheta_{oil} = 40 \pm 5 \text{ }^\circ\text{C}$)

Switching pressure differential (P → A) depending on cut-off pressure p_o (Type DA ...)

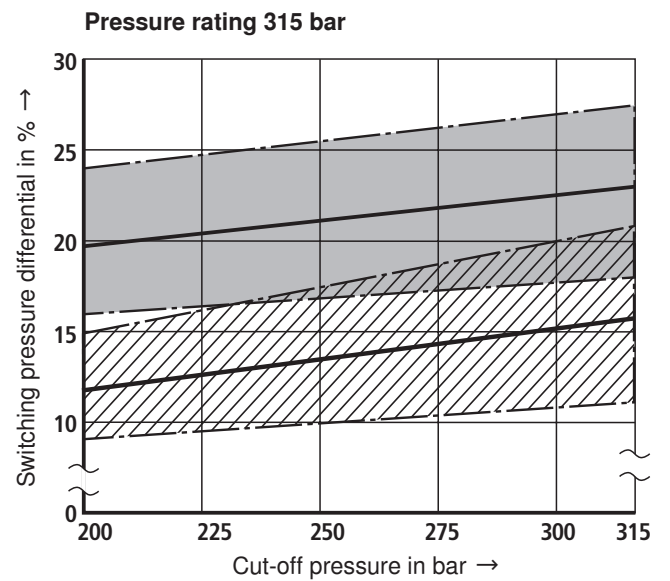
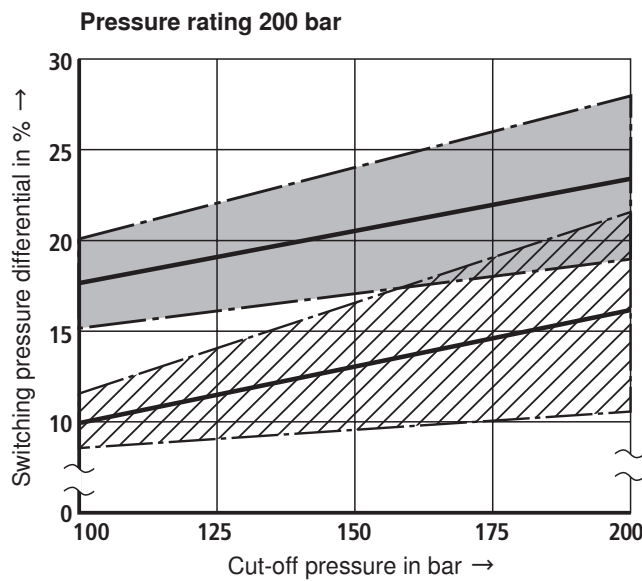
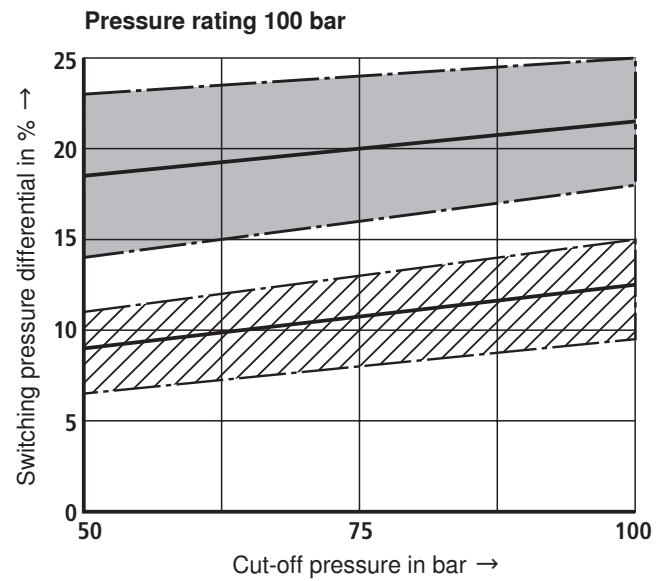
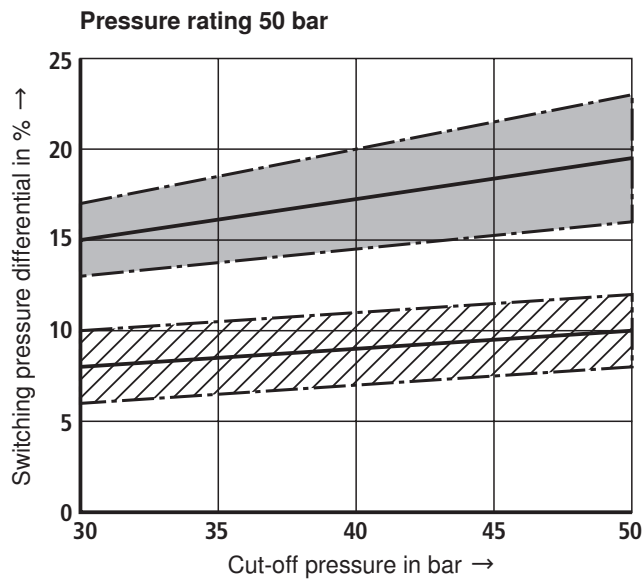

- Scatter range for version "10"
- Scatter range for version "17"

Version "FS" see page 12.

Characteristic curves (measured with HLP46, $\vartheta_{oil} = 40 \pm 5 \text{ }^\circ\text{C}$)

Switching pressure differential (P → A); pressure adjustment range p_U depending on the cut-off pressure p_o (Type DA ...FS)

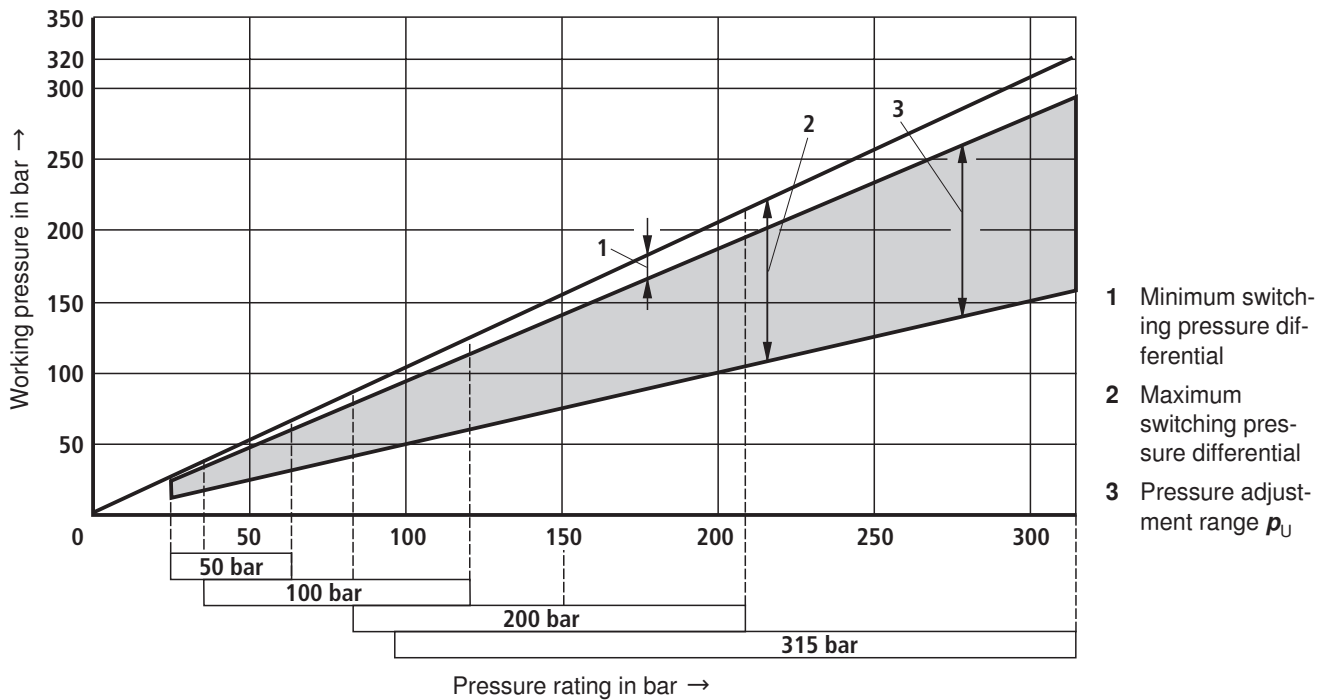

Characteristic curves (measured with HLP46, $\vartheta_{oil} = 40 \pm 5 \text{ }^\circ\text{C}$)

Δp - q_V -curves via check valve (P → A)

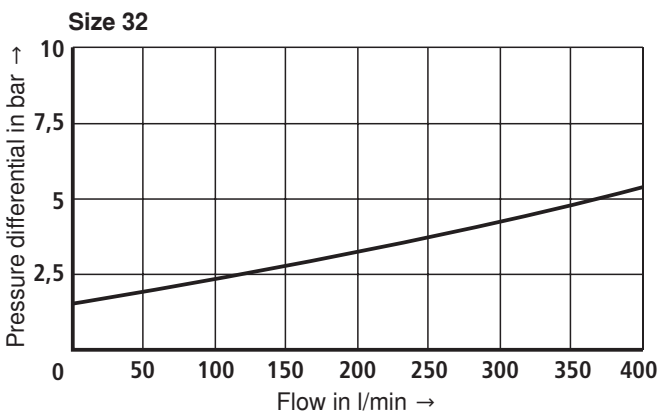
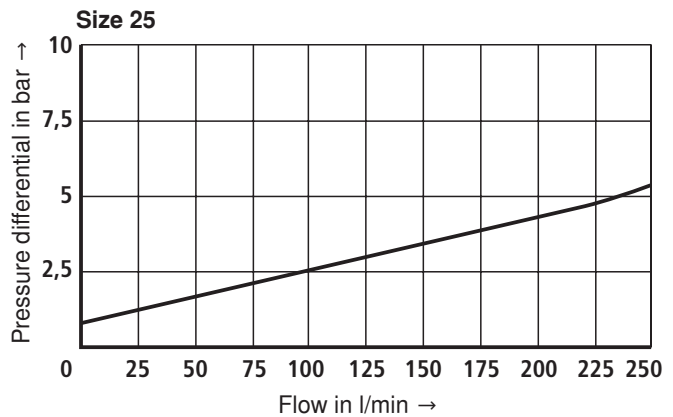
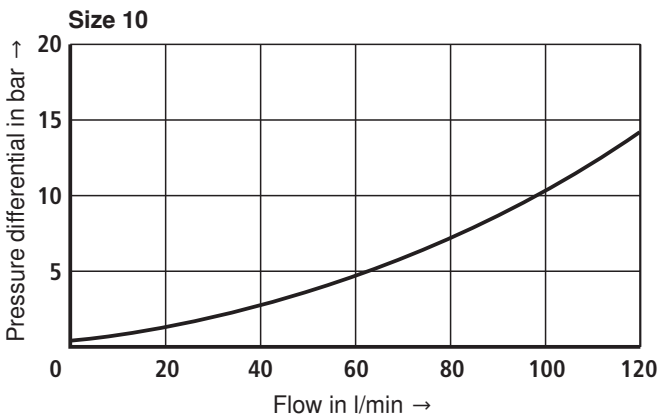

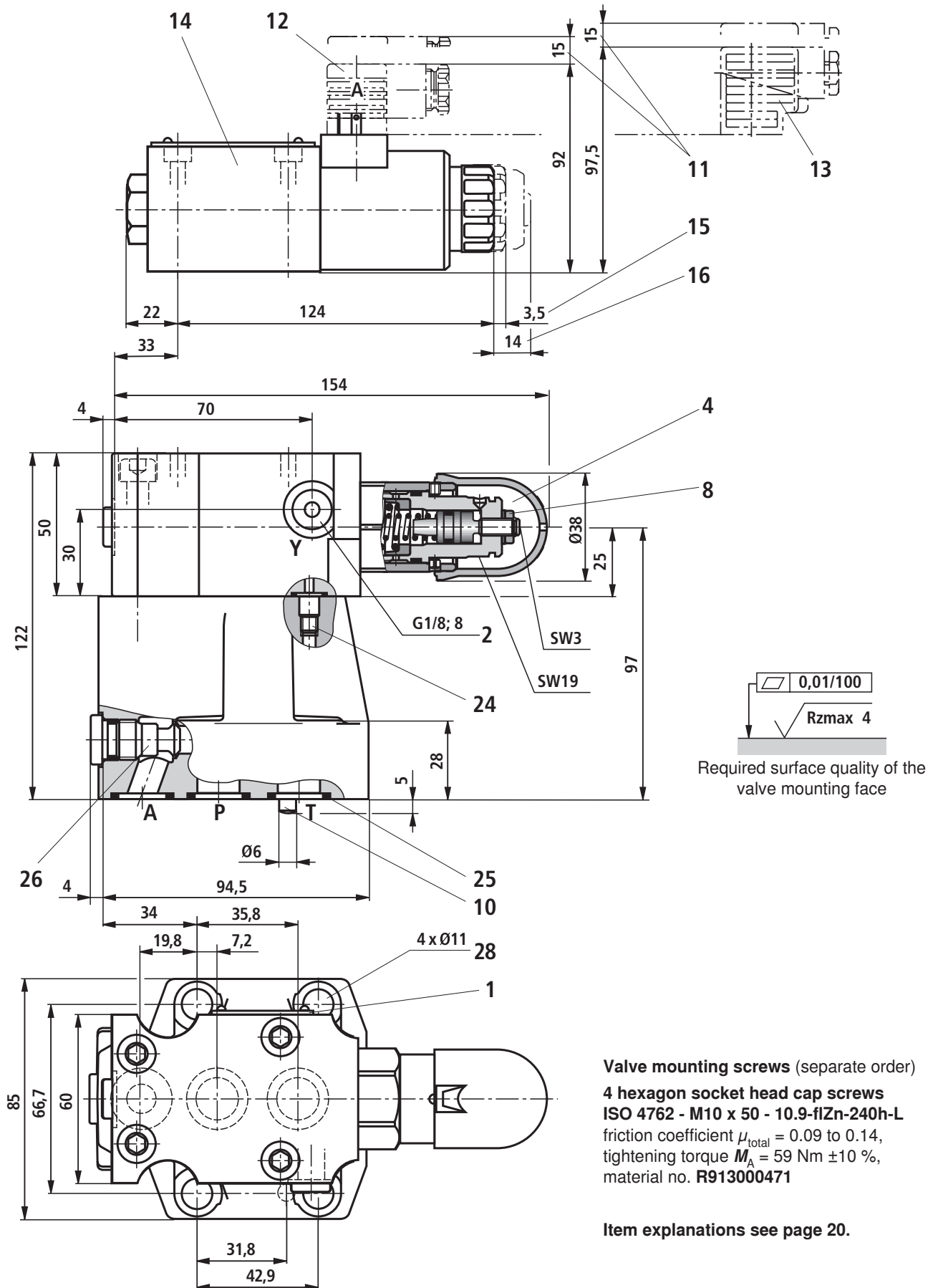
Unit dimensions: Type DA(W)...FS, size 10; subplate mounting (dimensions in mm)

Unit dimensions: Type DA(W)...., size 10; subplate mounting (dimensions in mm)

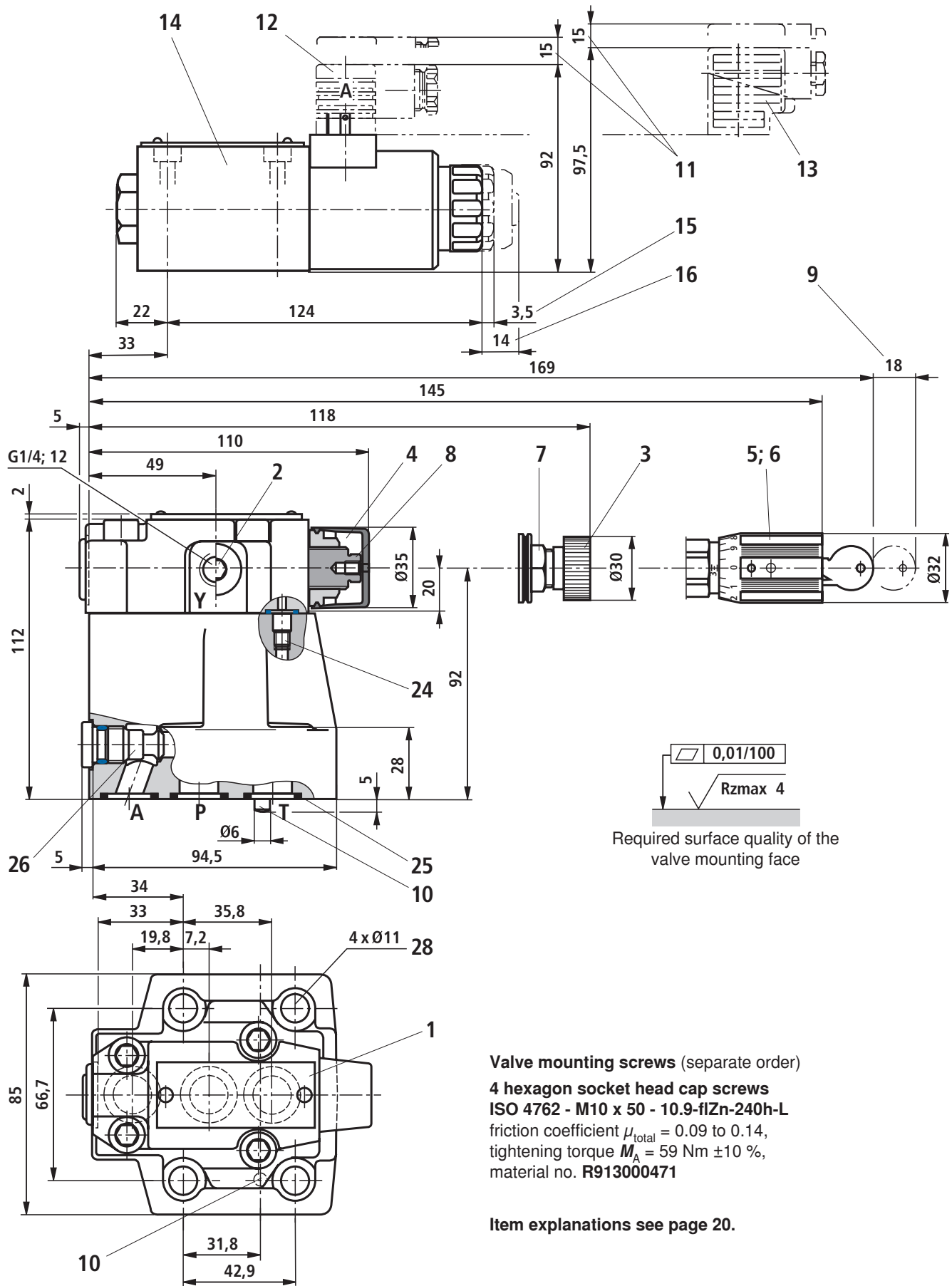

Valve mounting screws (separate order)

4 hexagon socket head cap screws
ISO 4762 - M10 x 50 - 10.9-fIZn-240h-L
 friction coefficient $\mu_{total} = 0.09$ to 0.14 ,
 tightening torque $M_A = 59 \text{ Nm} \pm 10 \%$,
 material no. **R913000471**

Item explanations see page 20.

Unit dimensions: Type DA(W)..., size 25 and 32; subplate mounting (dimensions in mm)

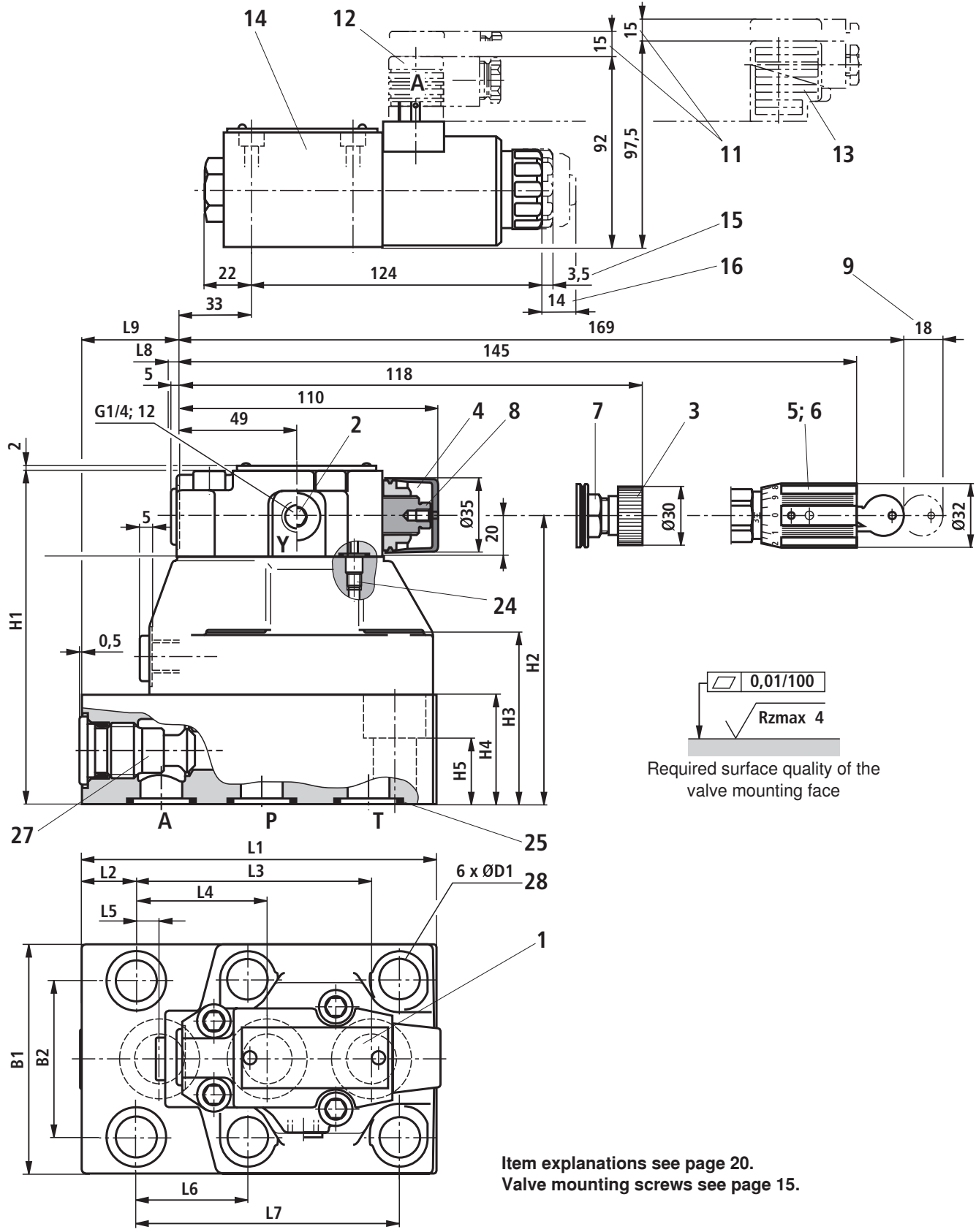

Item explanations see page 20.
Valve mounting screws see page 15.

Size	L1	L2	L3	L4	L5	L6	L7	L8	L9	B1	B2	H1	H2	H3	H4	H5	ØD1
25	149	19	101.6	57.1	12.7	46	112.7	12	42	100	70	144	124	72	46	28	18
32	190	34	127	63.5	12.7	50.8	139.7	22.5	63	115	82.5	165	145	93	67	45	20

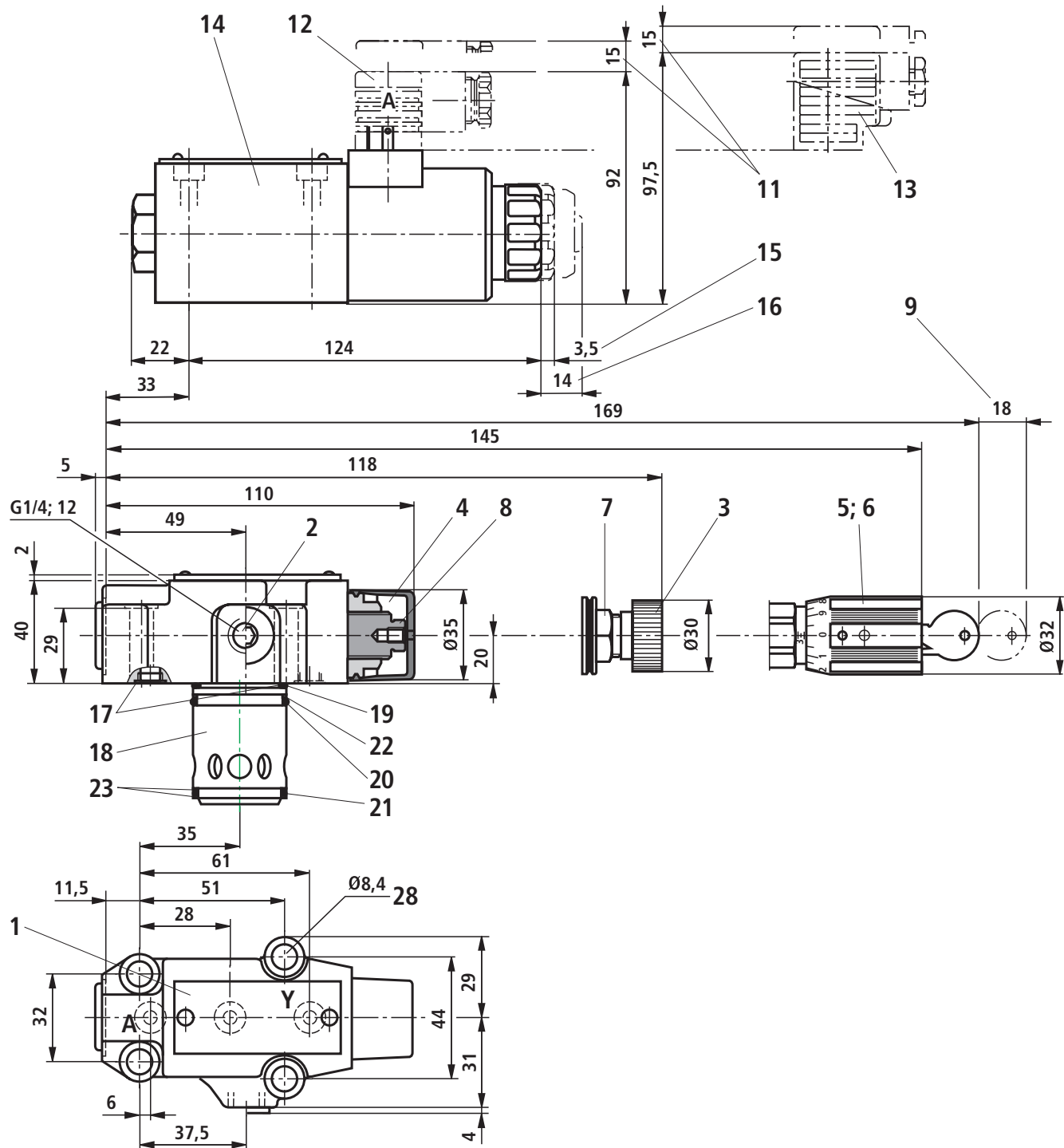
Unit dimensions: Type DA(W)C and DA(W)C 30; installation valve (dimensions in mm)

Valve mounting screws (separate order)
4 hexagon socket head cap screws
ISO 4762 - M8 x 40 - 10.9-fZn-240h-L
 with friction coefficient $\mu_{\text{total}} = 0.09$ to 0.14 ,
 tightening torque $M_A = 30 \text{ Nm} \pm 10 \%$,
 material no. R913000205

Item explanations see page 20.
Installation bore, see page 19.

Installation bore (dimensions in mm)

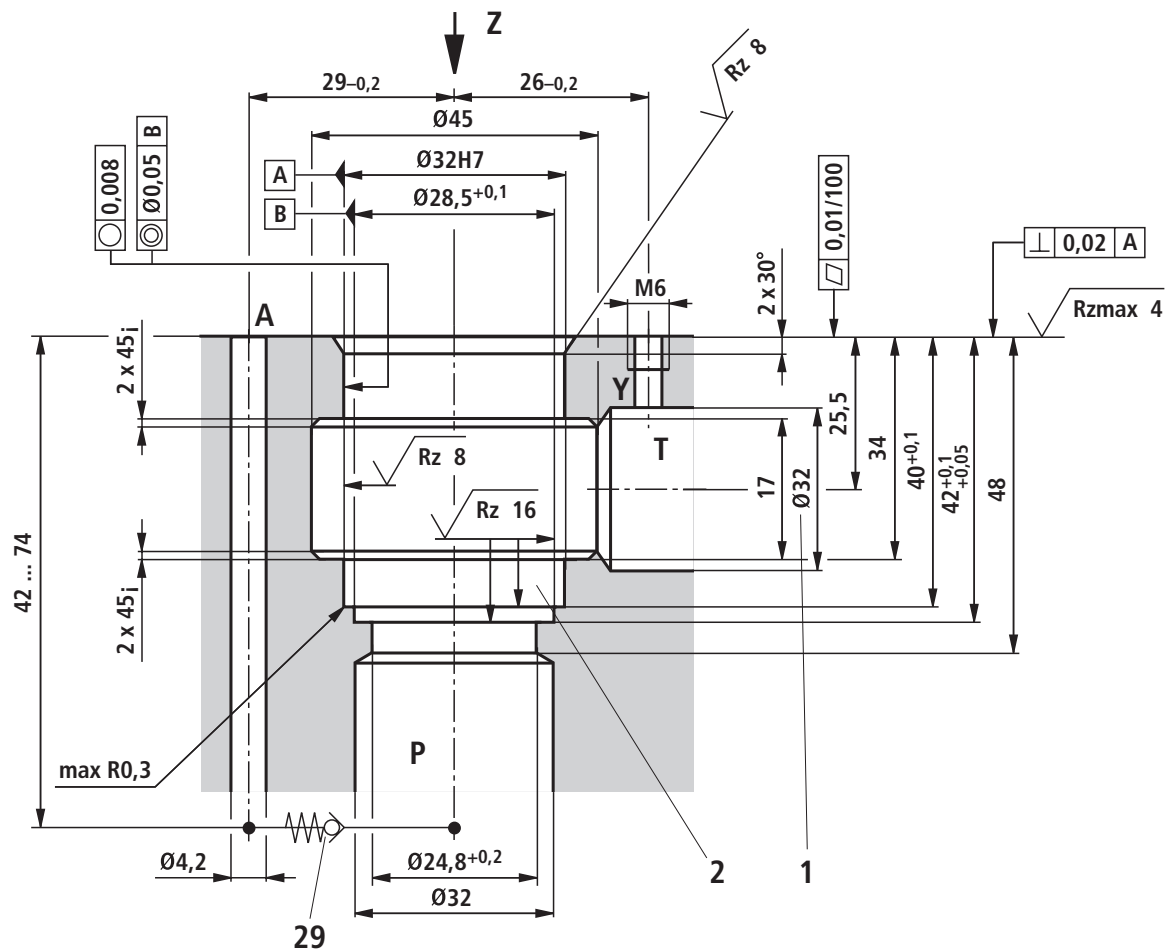

View "Z"

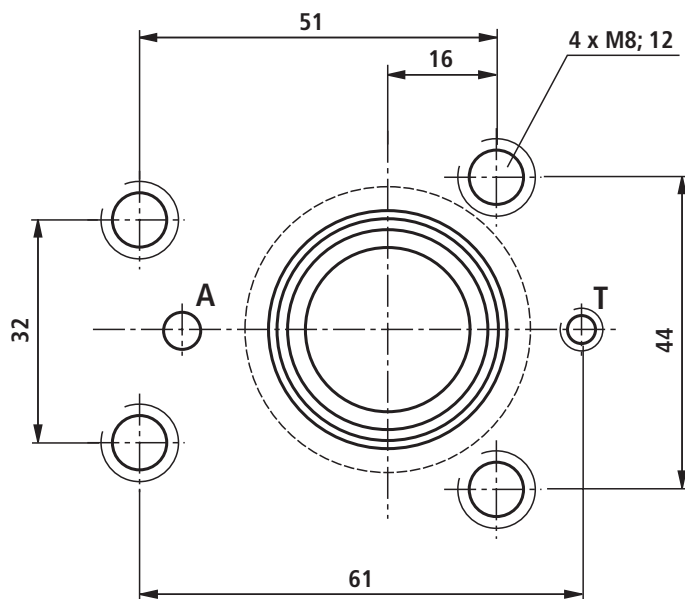

- 1 The Ø32 bore can tap a Ø45 bore at any point. However, it must be observed that the connection bore A and the mounting bore are not damaged!
- 2 A support ring and seal rings must be inserted into the bore before assembly of the main spool.
- 3 Check valve (separate order). When defining the position of the check valve and the pilot oil bore sufficient distance to the main spool insert bore must be kept.

Unit dimensions

- 1 Name plate
- 2 Y port for pilot oil return, external
- 3 Adjustment type "1"
- 4 Adjustment type "2"
- 5 Adjustment type "3"
- 6 Adjustment type "7"
- 7 Lock nut SW22
- 8 Hexagon SW10
- 9 Space required to remove the key
- 10 Locking pin
- 11 Space required for removing the mating connector
- 12 Mating connector **without** wiring
(separate order, see page 3)
- 13 Mating connector **with** wiring
(separate order, see page 3)
- 14 Directional spool valve, size 6 (data sheet 23178)
- 15 Dimension for solenoid **without** manual override
- 16 Dimension for solenoid **with** manual override "**N**"
- 17 Identical seal rings for ports A, Y
- 18 Main spool
- 19 O ring
- 20 O ring
- 21 O ring
- 22 Support ring
- 23 Support ring
- 24 Omitted with internal pilot oil return
- 25 Identical seal rings for ports A, P, T
- 26 Integrated check valve
- 27 Check valve (sandwich plate)
- 28 Valve mounting bores (valve mounting screws see pages 13 to 18)
- 29 Tightening torque $M_A = 60 \text{ Nm}$

Circuit examples

Hydraulic system with hydraulic accumulator

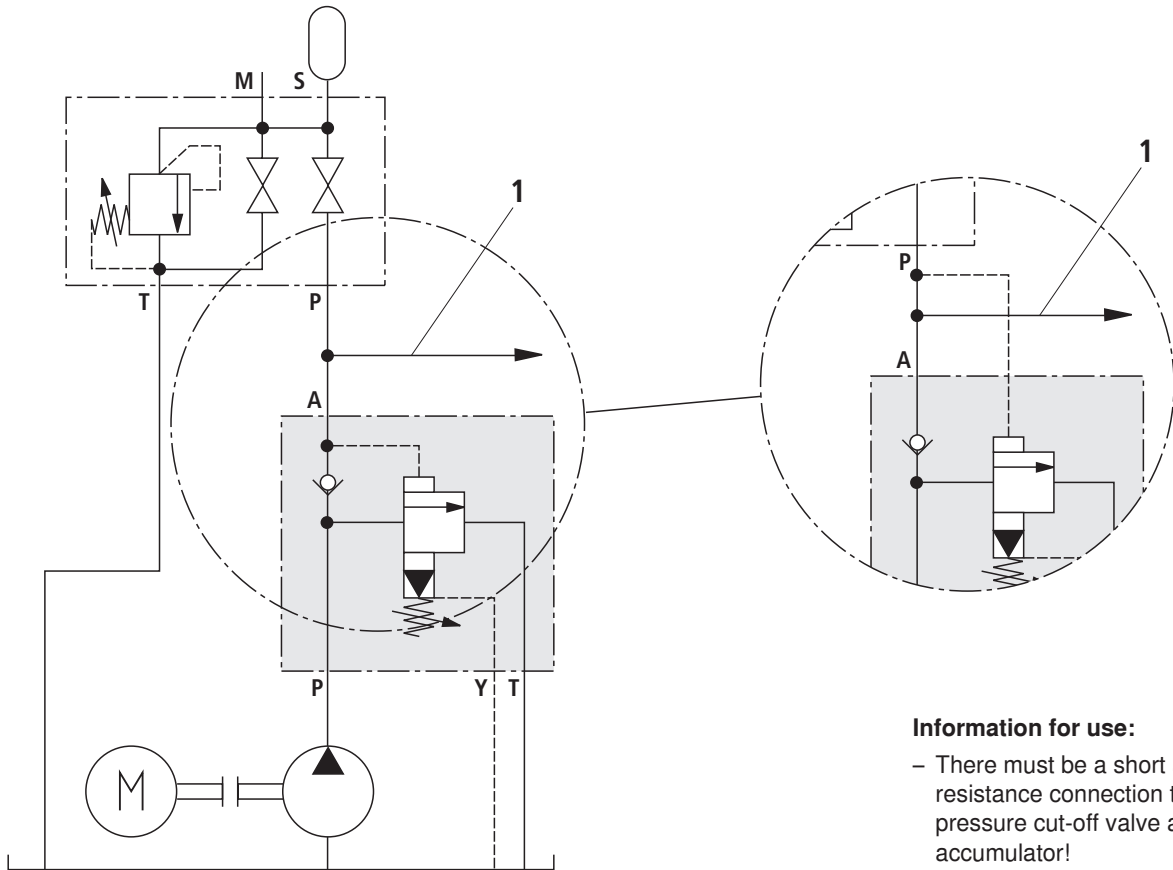

Information for use:

- There must be a short and low-resistance connection tubing between pressure cut-off valve and hydraulic accumulator!
- With high line resistance, use version "DA.../SO80" (separate control line from pilot control valve to hydraulic accumulator)!
- With high pump flow and small switching pressure differential values (10 %) "Y" version valves should preferably be used.

Hydraulic system with high and low pressure pump

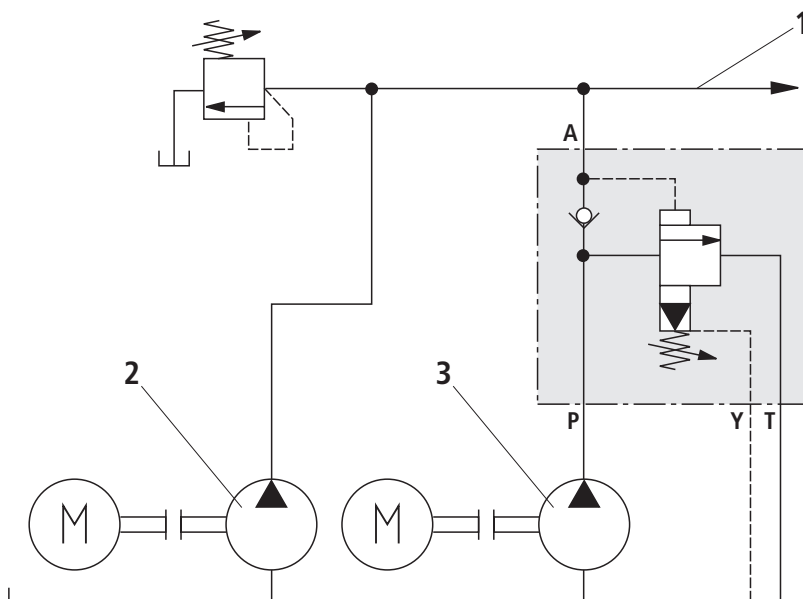

Attention!

- Accumulators must only be operated with suitable accumulator safety equipment!
- For "FS" versions pressure relief function for the pump pressure (towards tank) is not directly available but only indirectly via check valve and control line in the actuator channel.
- Please observe the safety instructions for circuit configuration!

- 1 To the actuator
- 2 High pressure pump
- 3 Low pressure pump

Notes

Bosch Rexroth AG
Hydraulics
Zum Eisengießer 1
97816 Lohr am Main, Germany
Phone +49 (0) 93 52 / 18-0
Fax +49 (0) 93 52 / 18-23 58
documentation@boschrexroth.de
www.boschrexroth.de

© This document, as well as the data, specifications and other information set forth in it, are the exclusive property of Bosch Rexroth AG. It may not be reproduced or given to third parties without its consent. The data specified above only serve to describe the product. No statements concerning a certain condition or suitability for a certain application can be derived from our information. The information given does not release the user from the obligation of own judgment and verification. It must be remembered that our products are subject to a natural process of wear and aging.

Notes

Bosch Rexroth AG
Hydraulics
Zum Eisengießer 1
97816 Lohr am Main, Germany
Phone +49 (0) 93 52 / 18-0
Fax +49 (0) 93 52 / 18-23 58
documentation@boschrexroth.de
www.boschrexroth.de

© This document, as well as the data, specifications and other information set forth in it, are the exclusive property of Bosch Rexroth AG. It may not be reproduced or given to third parties without its consent. The data specified above only serve to describe the product. No statements concerning a certain condition or suitability for a certain application can be derived from our information. The information given does not release the user from the obligation of own judgment and verification. It must be remembered that our products are subject to a natural process of wear and aging.

Notes

Bosch Rexroth AG
Hydraulics
Zum Eisengießer 1
97816 Lohr am Main, Germany
Phone +49 (0) 93 52 / 18-0
Fax +49 (0) 93 52 / 18-23 58
documentation@boschrexroth.de
www.boschrexroth.de

© This document, as well as the data, specifications and other information set forth in it, are the exclusive property of Bosch Rexroth AG. It may not be reproduced or given to third parties without its consent. The data specified above only serve to describe the product. No statements concerning a certain condition or suitability for a certain application can be derived from our information. The information given does not release the user from the obligation of own judgment and verification. It must be remembered that our products are subject to a natural process of wear and aging.