

**GRUPPO FRIZIONE / FRENO  
 A COMANDO PNEUMATICO  
 (FUNZIONAMENTO A SECCO)**

**AIR ACTUATED CLUTCH / BRAKE UNIT  
 (DRY OPERATING)**

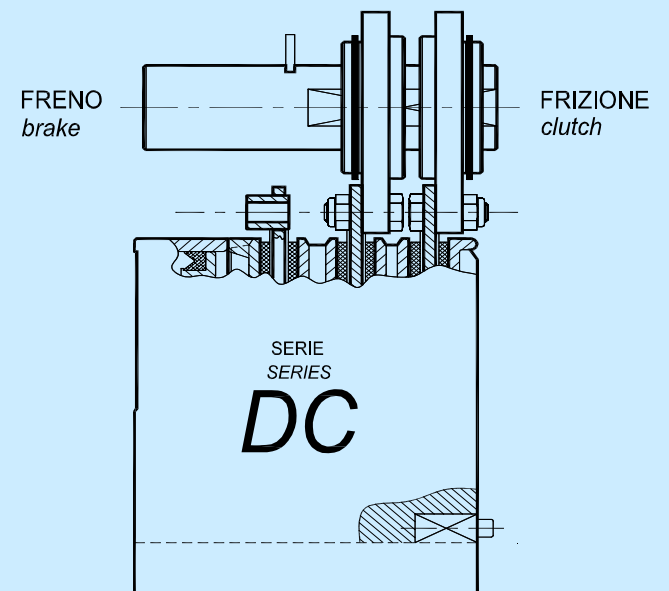
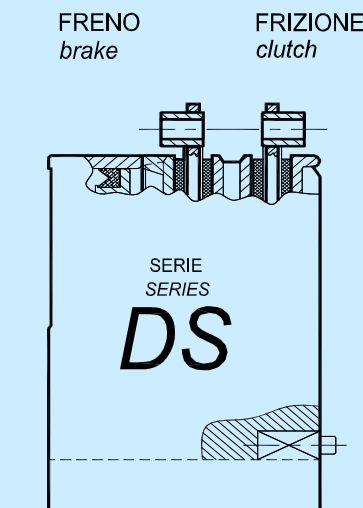
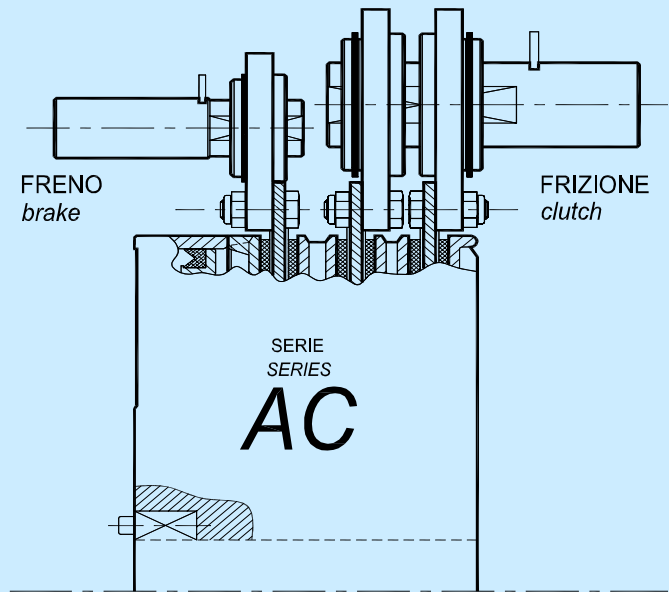
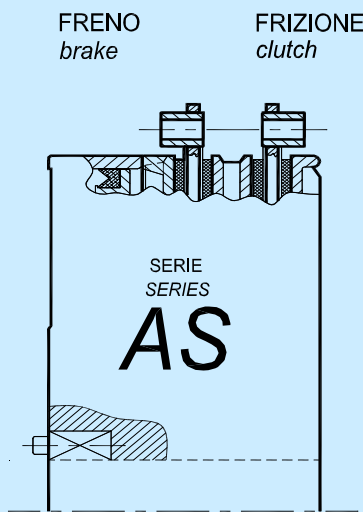

Grazie all'accresciuta area di spinta del pistone si hanno le seguenti CARATTERISTICHE:

- 1) ingombri ridotti
- 2) coppie freno e frizione incrementate
- 3) inerzia propria ridotta
- 4) grande versatilità d'applicazione

Due to the increase of the thrust area of the air piston there are the following FEATURES:

- 1) reduced OD dimensions
- 2) increase of the clutch and brake torques
- 3) reduced own inertia
- 4) great versatility of mounting

**COPPIE FRENO E FRIZIONE IN FUNZIONE  
DELLA PRESSIONE DI COMANDO E DEL NUMERO DI MOLLE  
CLUTCH AND BRAKE TORQUES  
DUE TO THE OPERATING PRESSURE AND THE SPRINGS NUMBER**

**SERIE AS e DS**

Grandezza Size	n° molle springs #	coppia freno [Nm] brake torque [lbin]	pressione apertura freno [bar (psi)] opening pressure [bar (psi)]	coppia frizione [Nm] alle pressioni [bar] clutch torque [lbin] at pressures [bar]					inerzia [kgm <sup>2</sup> ] inertia [lbrft <sup>2</sup> ]
				6 bar	5.5 bar	5 bar	4.5 bar	4 bar	
AS 0250	12	1800 (15,930)	2,9 (42)	1840 (16,280)	1500 (13,270)	1160 (10,260)	820 (7,250)	480 (4,240)	0.25 (5.93)
	10	1500 (13,270)	2,4 (35)	2210 (19,550)	1870 (16,540)	1530 (13,540)	1190 (10,530)	850 (7,520)	0.25 (5.93)
	8	1200 (10,620)	1,9 (28)	2580 (22,830)	2240 (19,820)	1900 (16,810)	1560 (13,800)	1220 (10,790)	0.24 (5.70)
	6	900 (7,960)	1,5 (22)	2950 (26,100)	2610 (23,090)	2270 (20,080)	1930 (17,080)	1590 (14,070)	0.24 (5.70)
AS 0470	16	3700 (32,700)	3,0 (44)	3790 (33,540)	3100 (27,430)	2420 (21,410)	1750 (15,480)	1070 (9,460)	0.87 (20.65)
	14	3250 (28,730)	2,6 (38)	4350 (38,490)	3650 (32,300)	3000 (26,550)	2300 (20,350)	1610 (14,240)	0.86 (20.41)
	12	2800 (24,750)	2,2 (32)	4900 (43,360)	4200 (37,170)	3550 (31,410)	2850 (25,220)	2200 (19,470)	0.85 (20.17)
	10	2350 (20,770)	1,9 (28)	5450 (48,230)	4750 (42,030)	4100 (36,280)	3400 (30,090)	2700 (23,890)	0.84 (19.93)
	8	1850 (16,350)	1,5 (22)	6000 (53,100)	5300 (46,900)	4620 (40,880)	3950 (34,950)	3250 (28,760)	0.83 (19.70)
6	1400 (12,370)	1,1 (16)	6550 (57,960)	5850 (51,770)	5160 (45,660)	4500 (39,820)	3800 (33,630)	0.82 (19.46)	
AS 0900	16	6800 (60,110)	3,0 (44)	7000 (61,950)	5750 (50,880)	4500 (39,820)	3250 (28,760)	2000 (17,700)	2.34 (55.53)
	14	5950 (52,590)	2,6 (38)	7950 (70,350)	6750 (59,730)	5500 (48,670)	4250 (37,610)	3000 (26,550)	2.31 (54.82)
	12	5100 (45,080)	2,3 (33)	8950 (79,200)	7700 (68,140)	6500 (57,520)	5250 (46,460)	4000 (35,400)	2.28 (54.10)
	10	4250 (37,570)	1,9 (28)	9950 (88,050)	8700 (76,990)	7450 (65,930)	6250 (55,310)	5000 (44,250)	2.25 (53.39)
	8	3400 (30,056)	1,5 (22)	10950 (96,900)	9700 (85,840)	8450 (74,780)	7200 (63,720)	6000 (53,100)	2.22 (52.68)
6	2550 (22,542)	1,1 (16)	11900 (105,310)	10700 (94,690)	9450 (83,630)	8200 (72,570)	6950 (61,500)	2.19 (51.97)	
AS 1400	15	11000 (97,240)	3,1 (45)	10950 (96,900)	9000 (79,650)	7050 (62,390)	5050 (44,690)	3100 (27,430)	4.65 (110.34)
	12	8800 (77,792)	2,5 (36)	13500 (119,470)	11500 (101,770)	9550 (84,510)	7600 (67,260)	5600 (49,560)	4.54 (107.73)
	9	6600 (58,340)	2,0 (29)	16000 (141,600)	14050 (124,340)	12100 (107,080)	10100 (89,380)	8150 (72,120)	4.43 (105.12)
	6	4400 (38,890)	1,2 (17)	18550 (164,160)	16550 (146,460)	14600 (129,210)	12650 (111,950)	10650 (94,250)	4.33 (102.75)
AS 1900	18	14000 (123,760)	3,0 (44)	14850 (131,420)	12300 (108,850)	9700 (85,840)	7150 (63,270)	4550 (40,260)	7.17 (170.14)
	15	11650 (103,100)	2,6 (38)	17500 (154,870)	14950 (132,300)	12400 (109,740)	9800 (86,730)	7250 (64,160)	7.02 (166.58)
	12	9300 (82,300)	2,1 (30)	20150 (178,320)	17600 (155,760)	15050 (133,190)	12450 (110,180)	9900 (87,610)	6.87 (163.03)
	9	7000 (61,950)	1,7 (25)	22800 (201,780)	20250 (179,210)	17700 (156,640)	15100 (133,630)	12550 (111,060)	6.73 (159.70)
	6	4650 (41,150)	1,3 (19)	25500 (225,670)	22900 (202,660)	20350 (180,090)	17750 (157,080)	15200 (134,520)	6.58 (156.14)
AS 2600	21	20000 (176,800)	3,0 (44)	21000 (185,850)	17350 (153,540)	13700 (121,240)	10050 (88,940)	6350 (56,190)	14.71 (349.07)
	18	17150 (151,600)	2,6 (38)	24300 (215,050)	20650 (182,750)	16950 (150,000)	13300 (117,700)	9650 (85,400)	14.45 (342.90)
	15	14300 (126,410)	2,2 (32)	27550 (243,810)	23900 (211,510)	20250 (179,210)	16550 (146,460)	12900 (114,160)	14.20 (336.97)
	12	11400 (100,770)	1,7 (25)	30850 (273,020)	27150 (240,270)	23500 (207,970)	18850 (166,820)	16200 (143,370)	13.94 (330.80)
	9	8600 (76,020)	1,3 (19)	34100 (301,780)	30450 (269,480)	26800 (237,180)	23100 (204,430)	19450 (172,130)	13.69 (324.86)
AS 3800	21	29000 (256,650)	3,0 (44)	30000 (265,500)	24700 (218,590)	19400 (171,690)	14100 (124,780)	8800 (77,880)	25.46 (604.17)
	18	24850 (219,920)	2,6 (38)	34800 (307,980)	29500 (261,070)	24200 (214,170)	18900 (167,260)	13600 (120,360)	25.07 (594.91)
	15	20700 (183,190)	2,2 (32)	39600 (350,460)	34300 (303,550)	29000 (256,650)	23700 (209,740)	18400 (162,840)	24.69 (585.89)
	12	16550 (146,460)	1,7 (25)	44350 (392,490)	39050 (345,590)	33800 (299,130)	28500 (252,220)	23200 (205,320)	24.30 (576.64)
	9	12400 (109,740)	1,3 (19)	49150 (434,970)	43850 (388,070)	38550 (341,160)	33250 (294,260)	28000 (247,800)	23.91 (567.38)
AS 5100	21	38500 (340,350)	3,0 (44)	39300 (347,800)	32350 (286,290)	25400 (224,790)	18400 (162,840)	11450 (101,330)	38.56 (915.03)
	18	33000 (291,720)	2,6 (38)	45650 (404,000)	38700 (342,490)	31700 (280,540)	24750 (219,030)	17750 (157,080)	37.91 (899.60)
	15	27500 (243,100)	2,2 (32)	52000 (460,200)	45000 (398,250)	38050 (336,740)	31050 (274,790)	24100 (213,280)	37.26 (884.18)
	12	22000 (194,480)	1,7 (25)	58300 (515,950)	51350 (454,440)	44350 (392,490)	37400 (330,990)	30450 (269,480)	36.61 (868.76)
	9	16500 (145,860)	1,3 (19)	64650 (572,150)	57650 (510,200)	50700 (448,690)	43700 (386,740)	36750 (325,230)	35.96 (853.33)
AS 7600	18	52000 (460,200)	3,0 (44)	55000 (486,750)	45400 (401,790)	35850 (317,270)	26300 (232,750)	16750 (148,230)	59.33 (1407.9)
	15	43300 (383,200)	2,5 (36)	64900 (574,360)	55350 (489,840)	45800 (405,330)	36250 (320,810)	26700 (236,290)	58.02 (1376.8)
	12	34650 (306,650)	2,0 (29)	74850 (662,420)	65300 (577,900)	55750 (493,380)	46200 (408,870)	36650 (324,350)	56.72 (1346.0)
	9	26000 (230,100)	1,5 (22)	84800 (750,480)	75250 (665,960)	65700 (581,440)	56150 (496,920)	46600 (412,410)	55.41 (1314.9)

# GRUPPO FRIZIONE-FRENO A COMANDO PNEUMATICO AIR ACTUATED CLUTCH-BRAKE UNIT

SERIE  
SERIES **AS-BB**

FRIZIONE E FRENO MONODISCO  
SINGLE-DISC CLUTCH AND BRAKE

MODALITA' DI FISSAGGIO SULL'ALBERO  
MODALITY OF ON-SHAFT MOUNTING

1) Con **chiavette** a 90° rispetto ai fori di entrata aria  
2) Con **calettatori** (interpellare ns. uff tec.)

1) **keyways** at 90° against air inlet holes  
2) with **locking device** (contact our engineering)

FRENO  
brake

FRIZIONE  
clutch

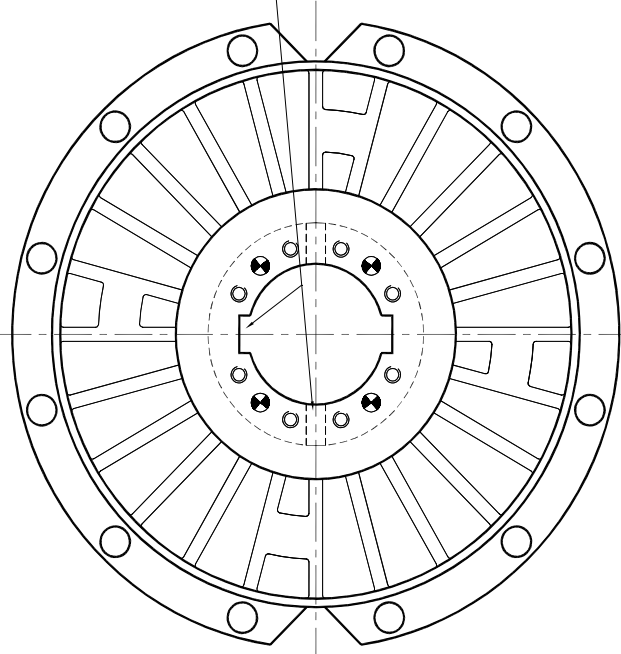
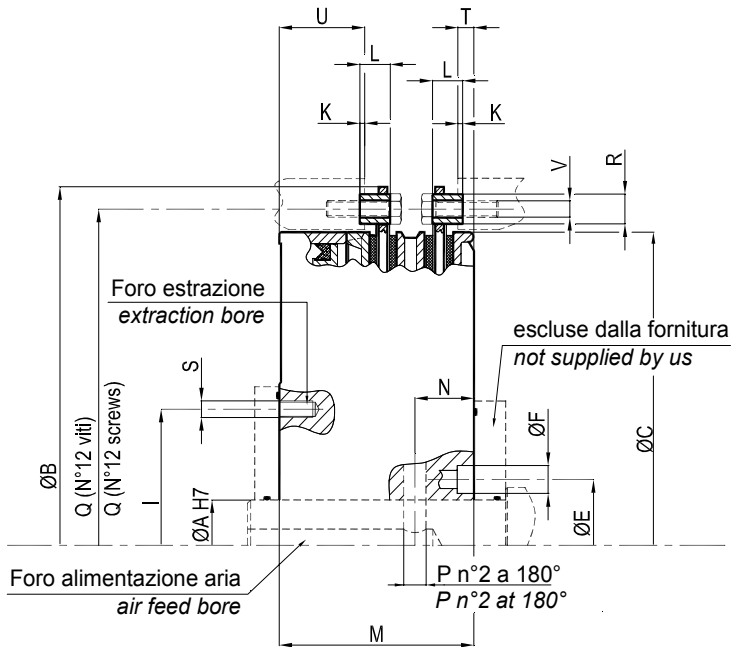

Grandezza Size	AS 0250	AS 0470	AS 0900	AS 1400	AS 1900	AS 2600	AS 3800	AS 5100	AS 7600
A max	80 (3.15)	95 (3.74)	125 (4.92)	140 (5.51)	160 (6.30)	180 (7.09)	200 (7.87)	220 (8.66)	240 (9.45)
A min	45 (1.77)	55 (2.17)	70 (2.76)	80 (3.15)	90 (3.54)	100 (3.94)	110 (4.33)	115 (4.53)	130 (5.12)
B	352 (13.86)	435 (17.13)	535 (21.06)	620 (24.41)	680 (26.77)	775 (30.51)	865 (34.06)	950 (37.40)	1025 (40.35)
C	304 (11.97)	380 (14.96)	465 (18.31)	543 (21.38)	593 (23.35)	675 (26.57)	755 (29.72)	830 (32.68)	905 (35.63)
E	95 (3.74)	115 (4.53)	152 (5.98)	174 (6.85)	194 (7.64)	220 (8.66)	255 (10.04)	280 (11.02)	310 (12.20)
F	14.5 (0.57)	17 (0.67)	22 (0.87)	27.5 (1.08)	28 (1.10)	31 (1.22)	37 (1.46)	37 (1.46)	41 (1.61)
K	3 (0.12)	3 (0.12)	3 (0.12)	3 (0.12)	4 (0.16)	4 (0.16)	5 (0.20)	5 (0.20)	5 (0.20)
L	20 (0.79)	19 (0.75)	24 (0.94)	26 (1.02)	30 (1.18)	35 (1.38)	41 (1.61)	45 (1.77)	45 (1.77)
M	94.5 (3.72)	122 (4.80)	145 (5.71)	165 (6.50)	180 (7.09)	205 (8.07)	228.5 (9.00)	240.5 (9.47)	263 (10.35)
N CON CALETTATORE N WITH LOCKING DEVICE	29 (1.14)	37 (1.46)	47 (1.85)	51 (2.00)	58 (2.28)	62 (2.44)	77 (3.03)	83 (3.27)	88,5 (3.48)
N SENZA CALETTATORE N WITHOUT LOCKING DEVICE	29 (1.14)	37 (1.46)	51 (2.00)	56 (2.20)	64 (2.51)	68 (2.67)	77 (3.03)	83 (3.27)	88,5 (3.48)
I	127 (5)	165 (6.49)	205 (8.07)	230 (9.05)	245 (9.64)	275 (10.82)	305 (12.0)	315 (12.4)	360 (14.17)
P	11 (0.43)	14 (0.55)	17 (0.67)	20 (0.79)	21 (0.83)	25 (0.98)	28 (1.10)	30 (1.18)	32.5 (1.28)
Q	325 (12.80)	408 (16.06)	500 (19.69)	584 (22.99)	640 (25.20)	725 (28.54)	810 (31.89)	890 (35.04)	965 (37.99)
R	15 (0.59)	18 (0.71)	25 (0.98)	25 (0.98)	30 (1.18)	35 (1.38)	41 (1.61)	45 (1.77)	45 (1.77)
S	M8	M10	M14	M18	M18	M20	M24	M24	M27
T	8 (0.31)	10 (0.39)	13,5 (0.53)	69,5 (2.73)	25 (0.98)	85,5 (3.36)	91,5 (3.6)	25 (0.98)	28 (1.10)
U	36.5 (1.44)	53,5 (2.10)	60,5 (2.38)	22,5 (0.88)	75 (2.95)	23,5 (0.92)	28,5 (1.12)	104 (4.09)	109,5 (4.31)
V	M8	M10	M14	M14	M16	M20	M24	M24	M24
1) Max velocità [RPM] 1) Max speed [RPM]	1750	1500	1250	1100	1000	850	750	700	650
Peso [kg] Weight [lb]	26 (57)	60 (132)	126 (277)	170 (374)	220 (484)	320 (704)	510 (1122)	600 (1320)	700 (1531)
Vol. cil. (nuovo) [lt] Cyl. Cap. (new) [in <sup>3</sup> ]	0.233 (14.25)	0.539 (32.90)	0.531 (32.40)	0.724 (44.17)	1.081 (65.97)	1.489 (90.83)	1.919 (117.11)	2.285 (139.43)	3.640 (222.18)
Vol. cil. (usurato) [lt] Cyl. Cap. (worn) [in <sup>3</sup> ]	0.455 (27.78)	0.970 (59.23)	1.035 (63.18)	1.412 (86.13)	2.119 (129.30)	2.923 (178.35)	3.769 (229.97)	4.487 (273.78)	7.801 (476.09)
Inerzia Corpo [Kgm <sup>2</sup> ] Inertia Body [lb-ft <sup>2</sup> ]	0,25 (5.93)	0.87 (20.65)	2.34 (55.53)	4.65 (110.34)	7.17 (170.14)	14.71 (349.07)	25.46 (604.17)	38.56 (915.03)	59.33 (1407.9)
Momento freno [Nm] Brake torque [lbin]	1800 (15,930)	3700 (32,708)	6800 (60,110)	11000 (97,240)	14000 (123,760)	20000 (176,800)	29000 (256,650)	38500 (340,350)	52000 (460,200)
Mom. Friz. (5,5bar) [Nm] Clutch torque (80Psi) [lbin]	1500 (13,270)	3100 (27,430)	5750 (50,880)	9000 (79,650)	12300 (108,850)	17350 (153,540)	24700 (218,590)	32350 (286,290)	45400 (401,790)

1) Non per operazioni in colpo singolo (consultare ns ufficio tecnico)

1) Not for single stroke operations (consult our engineering)

dimensioni - dimensions in mm (inches)

**GRUPPO FRIZIONE-FRENO A COMANDO PNEUMATICO**  
**AIR ACTUATED CLUTCH-BRAKE UNIT**

SERIE **AS-TT**

FRIZIONE E FRENO MONODISCO  
 SINGLE-DISC CLUTCH AND BRAKE

MODALITA' DI FISSAGGIO SULL'ALBERO  
 MODALITY OF ON-SHAFT MOUNTING

- 1) Con **chiavette** a 90° rispetto ai fori di entrata aria  
 2) Con **calettatori** (interpellare ns. uff tec.)  
 1) **keyways** at 90° against air inlet holes  
 2) **with locking devices** (contact our engineering)

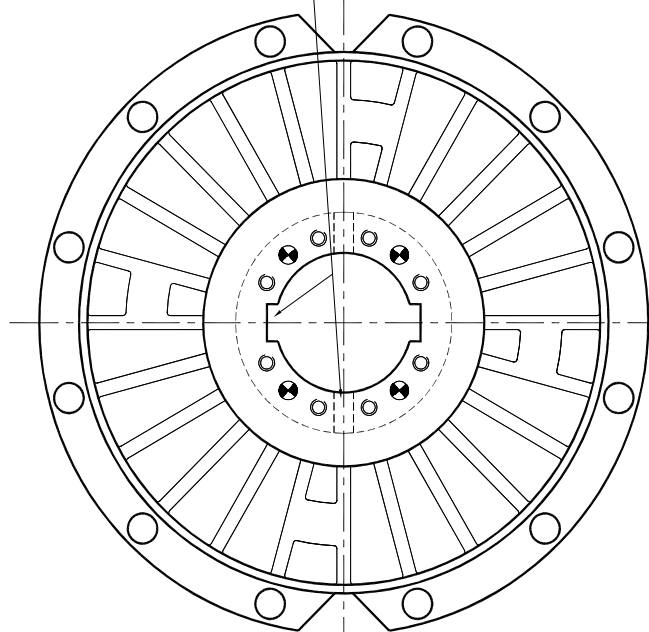
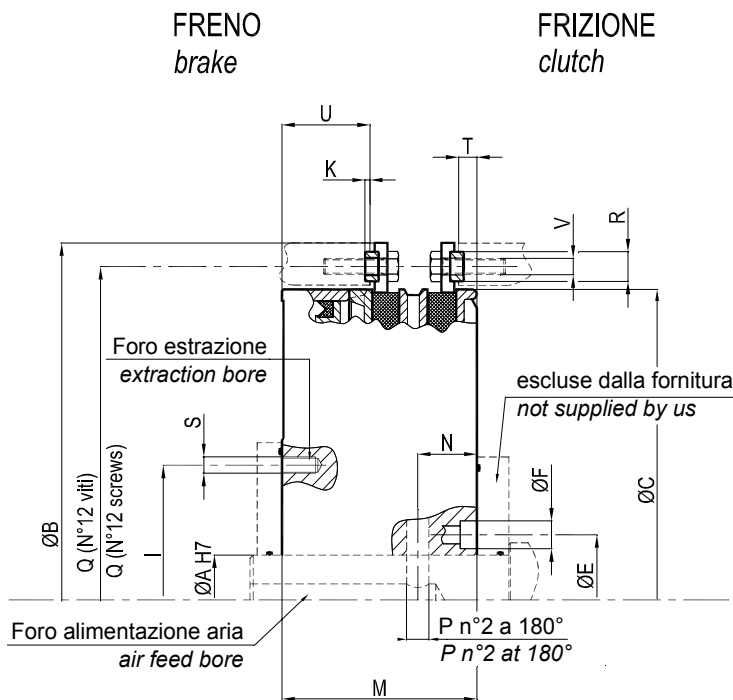

Grandezza Size	AS 0250	AS 0470	AS 0900	AS 1400	AS 1900	AS 2600	AS 3800	AS 5100	AS 7600
A max	80 (3.15)	95 (3.74)	125 (4.92)	140 (5.51)	160 (6.30)	180 (7.09)	200 (7.87)	220 (8.66)	240 (9.45)
A min	45 (1.77)	55 (2.17)	70 (2.76)	80 (3.15)	90 (3.54)	100 (3.94)	110 (4.33)	115 (4.53)	130 (5.12)
B	352 (13.86)	437 (17.20)	535 (21.06)	620 (24.41)	680 (26.77)	775 (30.51)	865 (34.06)	950 (37.40)	1025 (40.35)
C	304 (11.97)	380 (14.96)	465 (18.31)	543 (21.38)	593 (23.35)	675 (26.57)	755 (29.72)	830 (32.68)	905 (35.63)
E	95 (3.74)	115 (4.53)	152 (5.98)	174 (6.85)	194 (7.64)	220 (8.66)	255 (10.04)	280 (11.02)	310 (12.20)
F	14.5 (0.57)	17 (0.67)	22 (0.87)	27.5 (1.08)	28 (1.10)	31 (1.22)	37 (1.46)	37 (1.46)	41 (1.61)
K	3 (0.12)	3 (0.12)	3 (0.12)	3 (0.12)	4 (0.16)	4 (0.16)	5 (0.20)	5 (0.20)	5 (0.20)
M	94.5 (3.72)	122 (4.80)	145 (5.71)	165 (6.50)	180 (7.09)	205 (8.07)	228.5 (9.00)	240.5 (9.47)	263 (10.35)
N CON CALETTATORE N WITH LOCKING DEVICE	29 (1.14)	37 (1.46)	47 (1.85)	51 (2.00)	58 (2.28)	62 (2.44)	77 (3.03)	83 (3.27)	88,5 (3.48)
N SENZA CALETTATORE N WITHOUT LOCKING DEVICE	29 (1.14)	37 (1.46)	51 (2.00)	56 (2.20)	64 (2.51)	68 (2.67)	77 (3.03)	83 (3.27)	88,5 (3.48)
I	127 (5)	165 (6.49)	205 (8.07)	230 (9.05)	245 (9.64)	275 (10.82)	305 (12.0)	315 (12.4)	360 (14.17)
P	11 (0.43)	14 (0.55)	17 (0.67)	20 (0.79)	21 (0.83)	25 (0.98)	28 (1.10)	30 (1.18)	32.5 (1.28)
Q	325 (12.80)	408 (16.06)	500 (19.69)	584 (22.99)	640 (25.20)	725 (28.54)	810 (31.89)	890 (35.04)	965 (27.36)
R	15 (0.59)	18 (0.71)	25 (0.98)	25 (0.98)	30 (1.18)	35 (1.38)	40 (1.57)	45 (1.77)	45 (1.77)
S	M8	M10	M14	M18	M18	M20	M24	M24	M27
T	8 (0.31)	11.5 (0.45)	19 (0.75)	22 (0.86)	25 (0.98)	18 (0.71)	28,5 (1.12)	18 (0.71)	21.5 (0.85)
U	36.5 (1.44)	55 (2.17)	61 (2.40)	69 (2.71)	75 (2.95)	80 (3.15)	91.5 (3.60)	97 (3.82)	103 (4.05)
V	M8	M10	M14	M14	M16	M20	M24	M24	M24
1) Max velocità [RPM] 1) Max speed [RPM]	1750	1500	1250	1100	1000	850	750	700	650
Peso [kg] Weight [lb]	26 (57)	60 (132)	126 (277)	170 (374)	220 (484)	320 (704)	510 (1122)	600 (1320)	700 (1531)
Vol. cil. (nuovo) [lt] Cyl. Cap. (new) [in <sup>3</sup> ]	0.233 (14.25)	0.539 (32.90)	0.531 (32.40)	0.724 (44.17)	1.081 (65.97)	1.489 (90.83)	1.919 (117.11)	2.285 (139.43)	3.640 (222.18)
Vol. cil. (usurato) [lt] Cyl. Cap. (worn) [in <sup>3</sup> ]	0.455 (27.78)	0.970 (59.23)	1.035 (63.18)	1.412 (86.13)	2.119 (129.30)	2.923 (178.35)	3.769 (229.97)	4.487 (273.78)	7.801 (476.09)
Inerzia Corpo [Kgm <sup>2</sup> ] Inertia Body [lb-ft <sup>2</sup> ]	0,25 (5.93)	0.87 (20.65)	2.34 (55.53)	4.65 (110.34)	7.17 (170.14)	14.71 (349.07)	25.46 (604.17)	38.56 (915.03)	59.33 (1407.9)
Momento freno [Nm] Brake torque [lbin]	1800 (15,930)	3700 (32,708)	6800 (60,110)	11000 (97,240)	14000 (123,760)	20000 (176,800)	29000 (256,650)	38500 (340,350)	52000 (460,200)
Mom. Friz. (5,5bar) [Nm] Clutch torque (80Psi) [lbin]	1500 (13,270)	3100 (27,430)	5750 (50,880)	9000 (79,650)	12300 (108,850)	17350 (153,540)	24700 (218,590)	32350 (286,290)	45400 (401,790)

1) Non per operazioni in colpo singolo (consultare ns ufficio tecnico)  
 1) Not for single stroke operations (consult our engineering)



# GRUPPO FRIZIONE-FRENO A COMANDO PNEUMATICO AIR ACTUATED CLUTCH-BRAKE UNIT

SERIE  
SERIES **AS-CS**

FRIZIONE E FRENO MONODISCO  
SINGLE-DISC CLUTCH AND BRAKE

MODALITA' DI FISSAGGIO SULL'ALBERO

1) Con **chiavette** a 90° rispetto ai fori di entrata aria

MODALITY OF ON-SHAFT MOUNTING

2) Con **calettatori** (interpellare ns. uff tec.)

1) **keyways** at 90° against air inlet holes

2) with **locking devices** (contact our engineering)

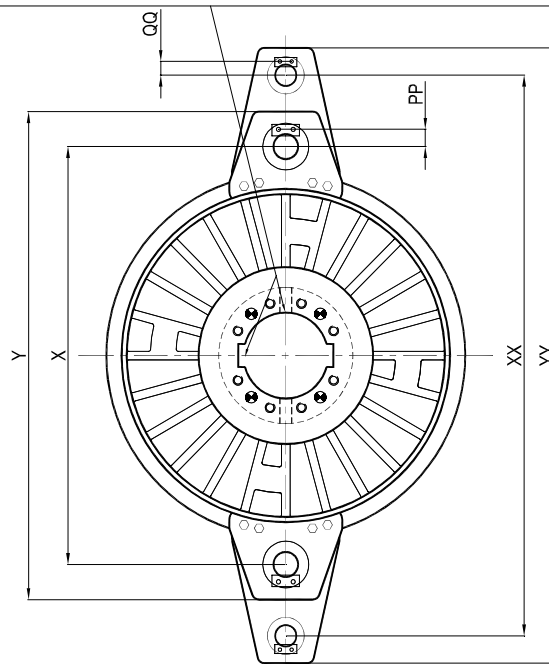
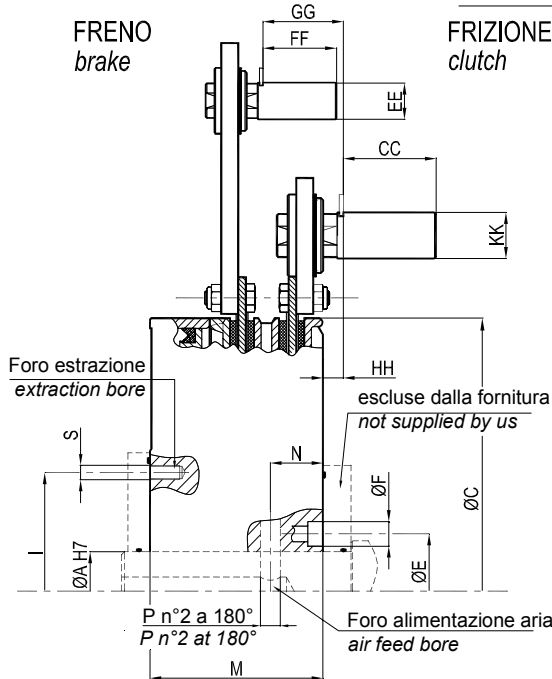

Grandezza Size	AS 0250	AS 0470	AS 0900	AS 1400	AS 1900	AS 2600	AS 3800	AS 5100	AS 7600
A max	80 (3.15)	95 (3.74)	125 (4.92)	140 (5.51)	160 (6.30)	180 (7.09)	200 (7.87)	220 (8.66)	240 (9.45)
A min	45 (1.77)	55 (2.17)	70 (2.76)	80 (3.15)	90 (3.54)	100 (3.94)	110 (4.33)	115 (4.53)	130 (5.12)
C	304 (11.97)	380 (14.96)	465 (18.31)	543 (21.38)	593 (23.35)	675 (26.57)	755 (29.72)	830 (32.68)	905 (35.63)
E	95 (3.74)	115 (4.53)	152 (5.98)	174 (6.85)	194 (7.64)	220 (8.66)	255 (10.04)	280 (11.02)	310 (12.20)
F	14.5 (0.57)	17 (0.67)	22 (0.87)	27.5 (1.08)	28 (1.10)	31 (1.22)	37 (1.46)	37 (1.46)	41 (1.61)
M	94.5 (3.72)	122 (4.80)	145 (5.71)	165 (6.50)	180 (7.09)	205 (8.07)	228.5 (9.00)	240.5 (9.47)	263 (10.35)
N CON CALETTATORE N WITH LOCKING DEVICE	29 (1.14)	37 (1.46)	47 (1.85)	51 (2.00)	58 (2.28)	62 (2.44)	77 (3.03)	83 (3.27)	88,5 (3.48)
N SENZA CALETTATORE N WITHOUT LOCKING DEVICE	29 (1.14)	37 (1.46)	51 (2.00)	56 (2.20)	64 (2.51)	68 (2.67)	77 (3.03)	83 (3.27)	88,5 (3.48)
P	11 (0.43)	14 (0.55)	17 (0.67)	20 (0.79)	21 (0.83)	25 (0.98)	28 (1.10)	30 (1.18)	32.5 (1.28)
S	M8	M10	M14	M18	M18	M20	M24	M24	M27
X	390 (15.35)	495 (19.49)	610 (24.02)	695 (27.36)	770 (30.31)	880 (34.65)	970 (38.19)	1100 (43.31)	1180 (46.46)
Y	449 (17.68)	575 (22.64)	708 (27.87)	793 (31.22)	910 (35.83)	1020 (40.16)	1130 (44.49)	1274 (50.16)	1344 (52.91)
I	127 (5)	165 (6.49)	205 (8.07)	230 (9.05)	245 (9.64)	275 (10.82)	305 (12.0)	315 (12.4)	360 (14.17)
HH	7 (0.27)	15 (0.59)	21.5 (0.85)	17 (0.66)	32.5 (1.28)	32 (1.26)	26 (1.02)	32 (1.26)	29.5 (1.16)
KK	22 (0.87)	32 (1.26)	45 (1.77)	45 (1.77)	60 (2.36)	60 (2.36)	65 (2.56)	75 (2.95)	75 (2.95)
CC	45 (1.77)	65 (2.56)	90 (3.54)	90 (3.54)	119 (4.69)	119 (4.69)	130 (5.12)	150 (5.91)	150 (5.91)
PP	P2* 15.5 (0.61)	P2* 21.5 (0.84)	P3* 29.5 (1.16)	P3* 29.5 (1.16)	P4* 39.5 (1.55)	P4* 39.5 (1.55)	P4* 42.5 (1.67)	P5* 52 (2.04)	P5* 53 (2.08)
XX	490 (19.29)	635 (25.00)	790 (31.10)	885 (34.84)	990 (38.98)	1135 (44.68)	1235 (48.62)	1450 (57.09)	1525 (60.04)
YY	533 (20.98)	700 (27.56)	870 (34.25)	967 (38.07)	1102 (43.39)	1255 (49.41)	1369 (53.90)	1610 (63.39)	1674 (65.91)
QQ	P1* 10.5 (0.41)	P2* 20 (0.79)	P2* 21.5 (0.84)	P2* 21.5 (0.84)	P3* 29.5 (1.16)	P3* 29.5 (1.16)	P4* 37.5 (1.47)	P4* 43 (1.67)	P4* 40 (1.57)
EE	16 (0.63)	30 (1.18)	32 (1.26)	32 (1.26)	45 (1.77)	45 (1.77)	55 (2.17)	65 (2.56)	65 (2.56)
FF	28 (1.10)	60 (2.36)	65 (2.56)	65 (2.56)	90 (3.54)	90 (3.54)	110 (4.33)	130 (5.12)	130 (5.12)
GG	41 (1.61)	52,5 (2.06)	77 (3.03)	84 (3.31)	91 (3.58)	106 (4.17)	106.5 (4.19)	108 (4.25)	123 (4.84)
1) Max velocità [RPM] 1) Max speed [RPM]	1750	1500	1250	1100	1000	850	750	700	650
Peso [kg] Weight [lb]	26 (57)	60 (132)	126 (277)	170 (374)	220 (484)	320 (704)	510 (1122)	600 (1320)	700 (1531)
Vol. cil. (nuovo) [lt] Cyl. Cap. (new) [in <sup>3</sup> ]	0.233 (14.25)	0.539 (32.90)	0.531 (32.40)	0.724 (44.17)	1.081 (65.97)	1.489 (90.83)	1.919 (117.11)	2.285 (139.43)	3.640 (222.18)
Vol. cil. (usurato) [lt] Cyl. Cap. (worm) [in <sup>3</sup> ]	0.455 (27.78)	0.970 (59.23)	1.035 (63.18)	1.412 (86.13)	2.119 (129.30)	2.923 (178.35)	3.769 (229.97)	4.487 (273.78)	7.801 (476.09)
Inerzia Corpo [Kgm <sup>2</sup> ] Inertia Body [lb-ft <sup>2</sup> ]	0,25 (5.93)	0.87 (20.65)	2.34 (55.53)	4.65 (110.34)	7.17 (170.14)	14.71 (349.07)	25.46 (604.17)	38.56 (915.03)	59.33 (1407.9)
Momento freno [Nm] Brake torque [lbin]	1800 (15,930)	3700 (32,708)	6800 (60,110)	11000 (97,240)	14000 (123,760)	20000 (176,800)	29000 (256,650)	38500 (340,350)	52000 (460,200)
Mom. Friz. (5,5bar) [Nm] Clutch torque (80Psi) [lbin]	1500 (13,270)	3100 (27,430)	5750 (50,880)	9000 (79,650)	12300 (108,850)	17350 (153,540)	24700 (218,590)	32350 (286,290)	45400 (401,790)

1) Non per operazioni in colpo singolo (consultare ns ufficio tecnico)

(\*) dimensioni delle piastine a pagina 16

dimensioni - dimensions in mm (inches)

1) Not for single stroke operations (consult our engineering)

(\*) keep plate's dimensions at page 16

# GRUPPO FRIZIONE-FRENO A COMANDO PNEUMATICO AIR ACTUATED CLUTCH-BRAKE UNIT

SERIE  
SERIES **DS-BB**

FRIZIONE E FRENO MONODISCO  
SINGLE-DISC CLUTCH AND BRAKE

MODALITA' DI FISSAGGIO SULL'ALBERO  
MODALITY OF ON-SHAFT MOUNTING

- 1) Con **chiavette** a 90° rispetto ai fori di entrata aria  
2) Con **calettatori** (interpellare ns. uff tec.)
- 1) **keyways** at 90° against air inlet holes  
2) **with locking devices** (contact our engineering)

FRENO  
brake

FRIZIONE  
clutch

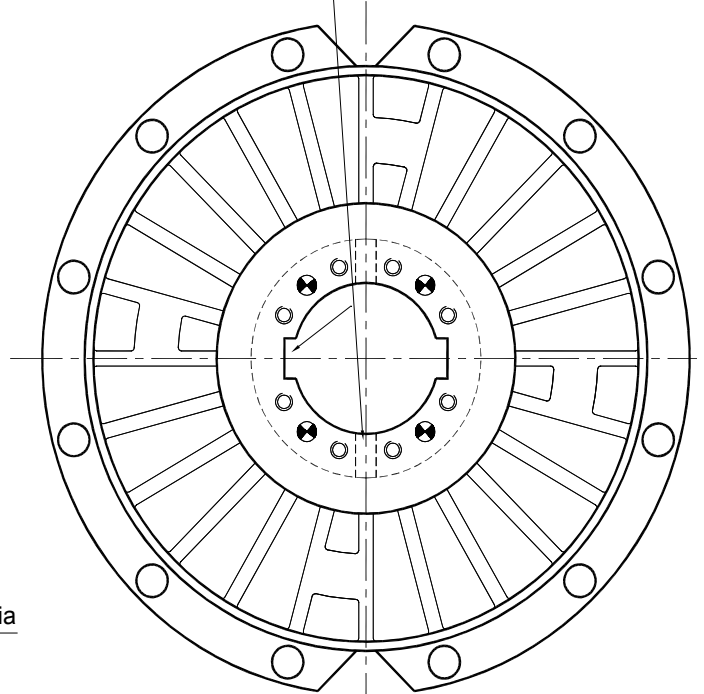
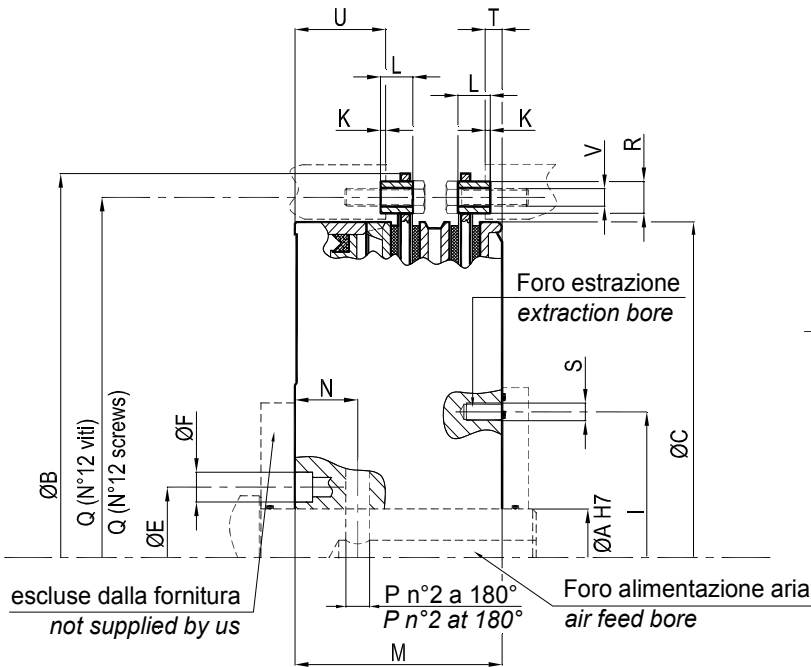

Grandezza Size	DS 0250	DS 0470	DS 0900	DS 1400	DS 1900	DS 2600	DS 3800	DS 5100	DS 7600
A max	80 (3.15)	95 (3.74)	125 (4.92)	140 (5.51)	160 (6.30)	180 (7.09)	200 (7.87)	220 (8.66)	240 (9.45)
A min	45 (1.77)	55 (2.17)	70 (2.76)	80 (3.15)	90 (3.54)	100 (3.94)	110 (4.33)	115 (4.53)	130 (5.12)
B	352 (13.86)	435 (17.13)	535 (21.06)	620 (24.41)	680 (26.77)	775 (30.51)	865 (34.06)	950 (37.40)	1025 (40.35)
C	304 (11.97)	380 (14.96)	465 (18.31)	543 (21.38)	593 (23.35)	675 (26.57)	755 (29.72)	830 (32.68)	905 (35.63)
E	95 (3.74)	115 (4.53)	152 (5.98)	174 (6.85)	194 (7.64)	220 (8.66)	255 (10.04)	280 (11.02)	310 (12.20)
F	14.5 (0.57)	17 (0.67)	22 (0.87)	27.5 (1.08)	28 (1.10)	31 (1.22)	37 (1.46)	37 (1.46)	41 (1.61)
K	3 (0.12)	3 (0.12)	3 (0.12)	3 (0.12)	4 (0.16)	4 (0.16)	5 (0.20)	5 (0.20)	5 (0.20)
L	20 (0.79)	19 (0.75)	24 (0.94)	26 (1.02)	30 (1.18)	35 (1.38)	41 (1.61)	45 (1.77)	45 (1.77)
M	94.5 (3.72)	122 (4.80)	145 (5.71)	165 (6.50)	180 (7.09)	205 (8.07)	228.5 (9.00)	240.5 (9.47)	263 (10.35)
N	39 (1.53)	54.5 (2.15)	59.5 (2.34)	66.5 (2.62)	72.5 (2.85)	83.5 (3.29)	94 (3.70)	103 (4.06)	116 (4.57)
I	127 (5)	194.5 (7.65)	244 (9.6)	287 (11.29)	313 (12.32)	378 (14.88)	423 (16.65)	471 (18.54)	487 (19.17)
P	11 (0.43)	14 (0.55)	17 (0.67)	20 (0.79)	21 (0.83)	25 (0.98)	28 (1.10)	30 (1.18)	32.5 (1.28)
Q	325 (12.80)	408 (16.06)	500 (19.69)	584 (22.99)	640 (25.20)	725 (28.54)	810 (31.89)	890 (35.04)	965 (37.99)
R	15 (0.59)	18 (0.71)	25 (0.98)	25 (0.98)	30 (1.18)	35 (1.38)	41 (1.61)	45 (1.77)	45 (1.77)
S	M8	M10	M14	M18	M18	M20	M24	M24	M27
T	8 (0.31)	7 (0.27)	13,5 (0.53)	22,5 (0.88)	25 (0.98)	23,5 (0.92)	91,5 (3.60)	25 (0.98)	28 (1.10)
U	36,5 (1.44)	53,5 (2.10)	60,5 (2.38)	69,5 (2.73)	75 (2.95)	85,5 (3.36)	28,5 (1.12)	140 (5.51)	109,5 (4.31)
V	M8	M10	M14	M14	M16	M20	M24	M24	M24
1) Max velocità [RPM] 1) Max speed [RPM]	1750	1500	1250	1100	1000	850	750	700	650
Peso [kg] Weight [lb]	26 (57)	60 (132)	126 (277)	170 (374)	220 (484)	320 (704)	510 (1122)	600 (1320)	700 (1531)
Vol. cil. (nuovo) [lt] Cyl. Cap. (new) [in <sup>3</sup> ]	0.233 (14.25)	0.539 (32.90)	0.531 (32.40)	0.724 (44.17)	1.081 (65.97)	1.489 (90.83)	1.919 (117.11)	2.285 (139.43)	3.640 (222.18)
Vol. cil. (usurato) [lt] Cyl. Cap. (worn) [in <sup>3</sup> ]	0.455 (27.78)	0.970 (59.23)	1.035 (63.18)	1.412 (86.13)	2.119 (129.30)	2.923 (178.35)	3.769 (229.97)	4.487 (273.78)	7.801 (476.09)
Inerzia Corpo [Kgm <sup>2</sup> ] Inertia Body [lb-ft <sup>2</sup> ]	0,25 (5.93)	0,87 (20.65)	2,34 (55.53)	4,65 (110.34)	7,17 (170.14)	14,71 (349.07)	25,46 (604.17)	38,56 (915.03)	59,33 (1407.9)
Momento freno [Nm] Brake torque [lbin]	1800 (15,930)	3700 (32,708)	6800 (60,110)	11000 (97,240)	14000 (123,760)	20000 (176,800)	29000 (256,650)	38500 (340,350)	52000 (460,200)
Mom. Friz. (5,5bar) [Nm] Clutch torque (80Psi) [lbin]	1500 (13,270)	3100 (27,430)	5750 (50,880)	9000 (79,650)	12300 (108,850)	17350 (153,540)	24700 (218,590)	32350 (286,290)	45400 (401,790)

1) Non per operazioni in colpo singolo (consultare ns ufficio tecnico)

dimensioni - dimensions in mm (inches)

1) Not for single stroke operations (consult our engineering)

# GRUPPO FRIZIONE-FRENO A COMANDO PNEUMATICO AIR ACTUATED CLUTCH-BRAKE UNIT

SERIE  
SERIES **DS-TT**

FRIZIONE E FRENO MONODISCO  
SINGLE-DISC CLUTCH AND BRAKE

MODALITA' DI FISSAGGIO SULL'ALBERO  
MODALITY OF ON-SHAFT MOUNTING

1) Con **chiavette** a 90° rispetto ai fori di entrata aria  
2) Con **calettatori** (interpellare ns. uff tec.)

1) **keyways** at 90° against air inlet holes  
2) with **locking devices** (contact our engineering)

FRENO  
brake

FRIZIONE  
clutch

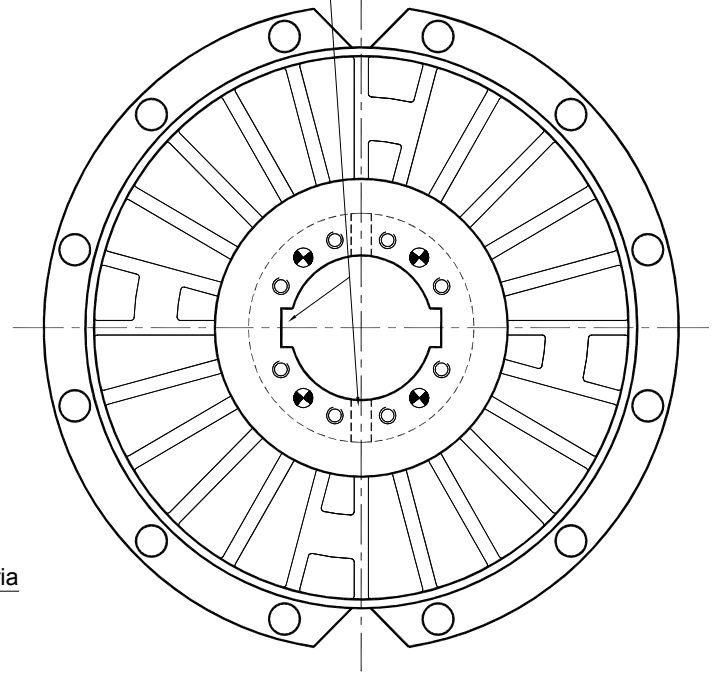
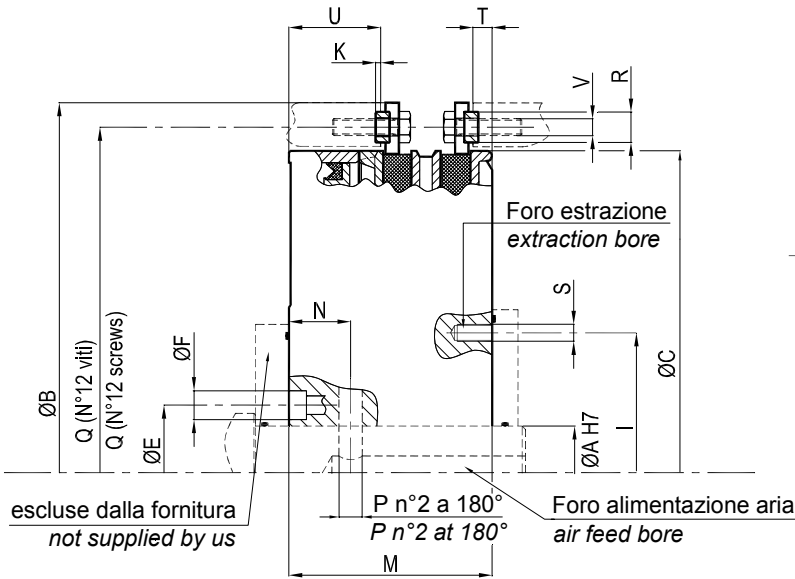

Grandezza Size	DS 0250	DS 0470	DS 0900	DS 1400	DS 1900	DS 2600	DS 3800	DS 5100	DS 7600
A max	80 (3.15)	95 (3.74)	125 (4.92)	140 (5.51)	160 (6.30)	180 (7.09)	200 (7.87)	220 (8.66)	240 (9.45)
A min	45 (1.77)	55 (2.17)	70 (2.76)	80 (3.15)	90 (3.54)	100 (3.94)	110 (4.33)	115 (4.53)	130 (5.12)
B	352 (13.86)	437 (17.20)	535 (21.06)	620 (24.41)	680 (26.77)	775 (30.51)	865 (34.06)	950 (37.40)	1025 (40.35)
C	304 (11.97)	380 (14.96)	465 (18.31)	543 (21.38)	593 (23.35)	675 (26.57)	755 (29.72)	830 (32.68)	905 (35.63)
E	95 (3.74)	115 (4.53)	152 (5.98)	174 (6.85)	194 (7.64)	220 (8.66)	255 (10.04)	280 (11.02)	310 (12.20)
F	14.5 (0.57)	17 (0.67)	22 (0.87)	27.5 (1.08)	28 (1.10)	31 (1.22)	37 (1.46)	37 (1.46)	41 (1.61)
K	3 (0.12)	3 (0.12)	3 (0.12)	3 (0.12)	4 (0.16)	4 (0.16)	5 (0.20)	5 (0.20)	5 (0.20)
M	94.5 (3.72)	122 (4.80)	145 (5.71)	165 (6.50)	180 (7.09)	205 (8.07)	228.5 (9.00)	240.5 (9.47)	263 (10.35)
N	39 (1.53)	54.5 (2.15)	59.5 (2.34)	66.5 (2.62)	72.5 (2.85)	83.5 (3.29)	94 (3.70)	103 (4.06)	116 (4.57)
I	127 (5)	194.5 (7.65)	244 (9.6)	287 (11.29)	313 (12.32)	378 (14.88)	423 (16.65)	471 (18.54)	487 (19.17)
P	11 (0.43)	14 (0.55)	17 (0.67)	20 (0.79)	21 (0.83)	25 (0.98)	28 (1.10)	30 (1.18)	32.5 (1.28)
Q	325 (12.80)	408 (16.06)	500 (19.69)	584 (22.99)	640 (25.20)	725 (28.54)	810 (31.89)	890 (35.04)	965 (37.99)
R	15 (0.59)	18 (0.71)	25 (0.98)	25 (0.98)	30 (1.18)	35 (1.38)	40 (1.57)	45 (1.77)	45 (1.77)
S	M8	M10	M14	M18	M18	M20	M24	M24	M27
T	8 (0.31)	11.5 (0.45)	19 (0.75)	22 (0.86)	25 (0.98)	18 (0.71)	28.5 (1.12)	18 (0.71)	21.5 (0.85)
U	36.5 (1.44)	55 (2.17)	61 (2.40)	69 (2.71)	75 (2.95)	80 (3.15)	91.5 (3.60)	97 (3.82)	103 (4.05)
V	M8	M10	M14	M14	M16	M20	M24	M24	M24
1) Max velocità [RPM] 1) Max speed [RPM]	1750	1500	1250	1100	1000	850	750	700	650
Peso [kg] Weight [lb]	26 (57)	60 (132)	126 (277)	170 (374)	220 (484)	320 (704)	510 (1122)	600 (1320)	700 (1531)
Vol. cil. (nuovo) [lt] Cyl. Cap. (new) [in <sup>3</sup> ]	0.233 (14.25)	0.539 (32.90)	0.531 (32.40)	0.724 (44.17)	1.081 (65.97)	1.489 (90.83)	1.919 (117.11)	2.285 (139.43)	3.640 (222.18)
Vol. cil. (usurato) [lt] Cyl. Cap. (worn) [in <sup>3</sup> ]	0.455 (27.78)	0.970 (59.23)	1.035 (63.18)	1.412 (86.13)	2.119 (129.30)	2.923 (178.35)	3.769 (229.97)	4.487 (273.78)	7.801 (476.09)
Inerzia Corpo [Kgm <sup>2</sup> ] Inertia Body [lb-ft <sup>2</sup> ]	0,25 (5.93)	0.87 (20.65)	2.34 (55.53)	4.65 (110.34)	7.17 (170.14)	14.71 (349.07)	25.46 (604.17)	38.56 (915.03)	59.33 (1407.9)
Momento freno [Nm] Brake torque [lbin]	1800 (15,930)	3700 (32,708)	6800 (60,110)	11000 (97,240)	14000 (123,760)	20000 (176,800)	29000 (256,650)	38500 (340,350)	52000 (460,200)
Mom. Friz. (5,5bar) [Nm] Clutch torque (80Psi) [lbin]	1500 (13,270)	3100 (27,430)	5750 (50,880)	9000 (79,650)	12300 (108,850)	17350 (153,540)	24700 (218,590)	32350 (286,290)	45400 (401,790)

1) Non per operazioni in colpo singolo (consultare ns ufficio tecnico)

dimensioni - dimensions in mm (inches)

1) Not for single stroke operations (consult our engineering)



# GRUPPO FRIZIONE-FRENO A COMANDO PNEUMATICO AIR ACTUATED CLUTCH-BRAKE UNIT

SERIE  
SERIES **DS-CC**

FRIZIONE E FRENO MONODISCO  
SINGLE-DISC CLUTCH AND BRAKE

MODALITA' DI FISSAGGIO SULL'ALBERO  
MODALITY OF ON-SHAFT MOUNTING

FRENO  
brake

FRIZIONE  
clutch

1) Con **chiavette** a 90° rispetto ai fori di entrata aria

2) Con **calettatori** (interpellare ns. uff tec.)

1) **keyways** at 90° against air inlet holes

2) **with locking devices** (contact our engineering)

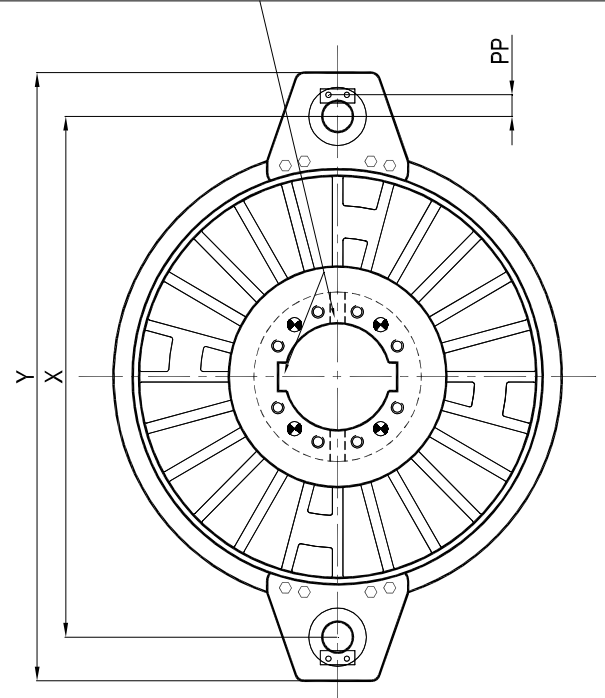
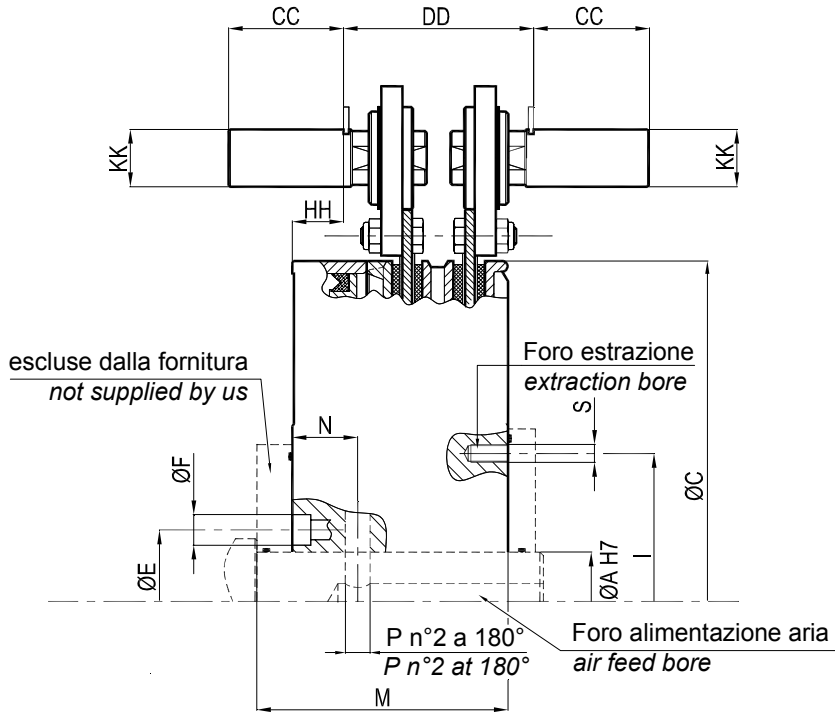

Grandezza Size	DS 0250	DS 0470	DS 0900	DS 1400	DS 1900	DS 2600	DS 3800	DS 5100	DS 7600
A max	80 (3.15)	95 (3.74)	125 (4.92)	140 (5.51)	160 (6.30)	180 (7.09)	200 (7.87)	220 (8.66)	240 (9.45)
A min	45 (1.77)	55 (2.17)	70 (2.76)	80 (3.15)	90 (3.54)	100 (3.94)	110 (4.33)	115 (4.53)	130 (5.12)
C	304 (11.97)	380 (14.96)	465 (18.31)	543 (21.38)	593 (23.35)	675 (26.57)	755 (29.72)	830 (32.68)	905 (35.63)
E	95 (3.74)	115 (4.53)	152 (5.98)	174 (6.85)	194 (7.64)	220 (8.66)	255 (10.04)	280 (11.02)	310 (12.20)
F	14.5 (0.57)	17 (0.67)	22 (0.87)	27.5 (1.08)	28 (1.10)	31 (1.22)	37 (1.46)	37 (1.46)	41 (1.61)
M	94.5 (3.72)	122 (4.80)	145 (5.71)	165 (6.50)	180 (7.09)	205 (8.07)	228.5 (9.00)	240.5 (9.47)	263 (10.35)
N	39 (1.53)	54.5 (2.15)	59.5 (2.34)	66.5 (2.62)	72.5 (2.85)	83.5 (3.29)	94 (3.70)	103 (4.06)	116 (4.57)
P	11 (0.43)	14 (0.55)	17 (0.67)	20 (0.79)	21 (0.83)	25 (0.98)	28 (1.10)	30 (1.18)	32.5 (1.28)
S	M8	M10	M14	M18	M18	M20	M24	M24	M27
X	390 (15.35)	495 (19.49)	610 (24.02)	695 (27.36)	770 (30.31)	880 (34.65)	970 (38.19)	1100 (43.31)	1180 (46.46)
Y	449 (17.68)	575 (22.64)	708 (27.87)	793 (31.22)	910 (35.83)	1020 (40.16)	1130 (44.49)	1274 (50.16)	1344 (52.91)
I	127 (5)	194.5 (7.65)	244 (9.6)	287 (11.29)	313 (12.32)	378 (14.88)	423 (16.65)	471 (18.54)	487 (19.17)
HH	21.5 (0.85)	31 (1.22)	20.5 (0.81)	29.5 (1.16)	17.5 (0.69)	30 (1.18)	37 (1.46)	49.5 (1.95)	51 (2.01)
KK	22 (0.87)	32 (1.26)	45 (1.77)	45 (1.77)	60 (2.36)	60 (2.36)	65 (2.56)	75 (2.95)	75 (2.95)
CC	45 (1.77)	65 (2.56)	90 (3.54)	90 (3.54)	119 (4.69)	119 (4.69)	130 (5.12)	150 (5.91)	150 (5.91)
DD	80 (3.15)	104 (4.09)	146 (5.75)	153 (6.02)	195 (7.68)	207 (8.15)	217.5 (8.56)	223 (8.78)	241.5 (9.51)
PP	P2* 15.5 (0.61)	P2* 21.5 (0.84)	P3* 29.5 (1.16)	P3* 29.5 (1.16)	P4* 39.5 (1.55)	P4* 39.5 (1.55)	P4* 42.5 (1.67)	P5* 52 (2.04)	P5* 53 (2.08)
1) Max velocità [RPM] 1) Max speed [RPM]	1750	1500	1250	1100	1000	850	750	700	650
Peso [kg] Weight [lb]	26 (57)	60 (132)	126 (277)	170 (374)	220 (484)	320 (704)	510 (1122)	600 (1320)	700 (1531)
Vol. cil. (nuovo) [lt] Cyl. Cap. (new) [in <sup>3</sup> ]	0.233 (14.25)	0.539 (32.90)	0.531 (32.40)	0.724 (44.17)	1.081 (65.97)	1.489 (90.83)	1.919 (117.11)	2.285 (139.43)	3.640 (222.18)
Vol. cil. (usurato) [lt] Cyl. Cap. (worn) [in <sup>3</sup> ]	0.455 (27.78)	0.970 (59.23)	1.035 (63.18)	1.412 (86.13)	2.119 (129.30)	2.923 (178.35)	3.769 (229.97)	4.487 (273.78)	7.801 (476.09)
Inerzia Corpo [Kgm <sup>2</sup> ] Inertia Body [lb-ft <sup>2</sup> ]	0,25 (5.93)	0.87 (20.65)	2.34 (55.53)	4.65 (110.34)	7.17 (170.14)	14.71 (349.07)	25.46 (604.17)	38.56 (915.03)	59.33 (1407.9)
Momento freno [Nm] Brake torque [lbin]	1800 (15,930)	3700 (32,708)	6800 (60,110)	11000 (97,240)	14000 (123,760)	20000 (176,800)	29000 (256,650)	38500 (340,350)	52000 (460,200)
Mom. Friz. (5,5bar) [Nm] Clutch torque (80Psi) [lbin]	1500 (13,270)	3100 (27,430)	5750 (50,880)	9000 (79,650)	12300 (108,850)	17350 (153,540)	24700 (218,590)	32350 (286,290)	45400 (401,790)

1) Non per operazioni in colpo singolo (consultare ns ufficio tecnico)

(\*) dimensioni delle piastrine a pagina 16

dimensioni - dimensions in mm (inches)

1) Not for single stroke operations (consult our engineering)

(\*) keep plate's dimensions at page 16

# GRUPPO FRIZIONE-FRENO A COMANDO PNEUMATICO AIR ACTUATED CLUTCH-BRAKE UNIT

SERIE DS-CS  
SERIES

FRIZIONE E FRENO MONODISCO  
SINGLE-DISC CLUTCH AND BRAKE

MODALITA' DI FISSAGGIO SULL'ALBERO

1) Con **chiavette** a 90° rispetto ai fori di entrata aria

MODALITY OF ON-SHAFT MOUNTING

2) Con **calettatori** (interpellare ns. uff tec.)

1) **keyways** at 90° against air inlet holes

2) **with locking devices** (contact our engineering)

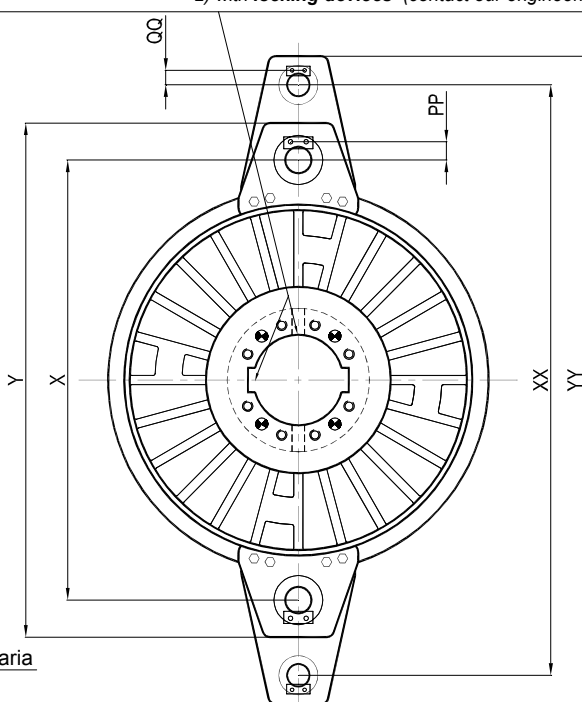
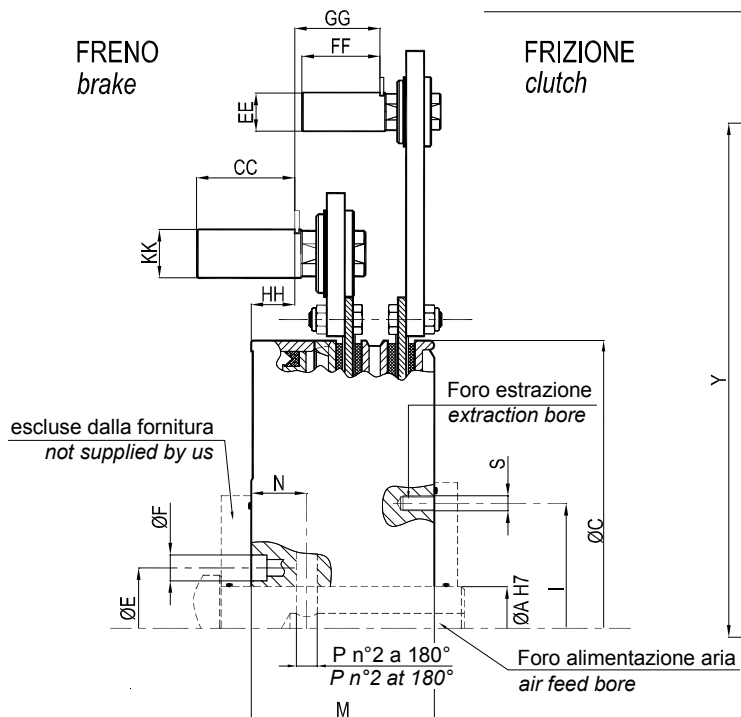

Grandezza Size	DS 0250	DS 0470	DS 0900	DS 1400	DS 1900	DS 2600	DS 3800	DS 5100	DS 7600
A max	80 (3.15)	95 (3.74)	125 (4.92)	140 (5.51)	160 (6.30)	180 (7.09)	200 (7.87)	220 (8.66)	240 (9.45)
A min	45 (1.77)	55 (2.17)	70 (2.76)	80 (3.15)	90 (3.54)	100 (3.94)	110 (4.33)	115 (4.53)	130 (5.12)
C	304 (11.97)	380 (14.96)	465 (18.31)	543 (21.38)	593 (23.35)	675 (26.57)	755 (29.72)	830 (32.68)	905 (35.63)
E	95 (3.74)	115 (4.53)	152 (5.98)	174 (6.85)	194 (7.64)	220 (8.66)	255 (10.04)	280 (11.02)	310 (12.20)
F	14.5 (0.57)	17 (0.67)	22 (0.87)	27.5 (1.08)	28 (1.10)	31 (1.22)	37 (1.46)	37 (1.46)	41 (1.61)
M	94.5 (3.72)	122 (4.80)	145 (5.71)	165 (6.50)	180 (7.09)	205 (8.07)	228.5 (9.00)	240.5 (9.47)	263 (10.35)
N	39 (1.53)	54.5 (2.15)	59.5 (2.34)	66.5 (2.62)	72.5 (2.85)	83.5 (3.29)	94 (3.70)	103 (4.06)	116 (4.57)
P	11 (0.43)	14 (0.55)	17 (0.67)	20 (0.79)	21 (0.83)	25 (0.98)	28 (1.10)	30 (1.18)	32.5 (1.28)
S	M8	M10	M14	M18	M18	M20	M24	M24	M27
X	390 (15.35)	495 (19.49)	610 (24.02)	695 (27.36)	770 (30.31)	880 (34.65)	970 (38.19)	1100 (43.31)	1180 (46.46)
Y	449 (17.68)	575 (22.64)	708 (27.87)	793 (31.22)	910 (35.83)	1020 (40.16)	1130 (44.49)	1274 (50.16)	1344 (52.91)
I	127 (5)	194.5 (7.65)	244 (9.6)	287 (11.29)	313 (12.32)	378 (14.88)	423 (16.65)	471 (18.54)	487 (19.17)
HH	21.5 (0.85)	31 (1.22)	20.5 (0.81)	29.5 (1.16)	17.5 (0.69)	30 (1.18)	37 (1.46)	45.5 (1.79)	51 (2.01)
KK	22 (0.87)	32 (1.26)	45 (1.77)	45 (1.77)	60 (2.36)	60 (2.36)	65 (2.56)	75 (2.95)	75 (2.95)
CC	45 (1.77)	65 (2.56)	90 (3.54)	90 (3.54)	119 (4.69)	119 (4.69)	130 (5.12)	150 (5.91)	150 (5.91)
PP	P2* 15.5 (0.61)	P2* 21.5 (0.84)	P3* 29.5 (1.16)	P3* 29.5 (1.16)	P4* 39.5 (1.55)	P4* 39.5 (1.55)	P4* 42.5 (1.67)	P5* 52 (2.05)	P5* 53 (2.08)
XX	490 (19.29)	635 (25.00)	790 (31.10)	885 (34.84)	990 (38.98)	1135 (44.68)	1235 (48.62)	1450 (57.09)	1525 (60.04)
YY	533 (20.98)	700 (27.56)	870 (34.25)	967 (38.07)	1102 (43.39)	1255 (49.41)	1369 (53.90)	1610 (63.39)	1674 (65.91)
QQ	P1* 10.5 (0.41)	P2* 20 (0.79)	P2* 21.5 (0.84)	P2* 21.5 (0.84)	P3* 29.5 (1.16)	P3* 29.5 (1.16)	P4* 37.5 (1.47)	P4* 43 (1.69)	P4* 40 (1.57)
EE	16 (0.63)	30 (1.18)	32 (1.26)	32 (1.26)	45 (1.77)	45 (1.77)	55 (2.17)	65 (2.56)	65 (2.56)
FF	28 (1.10)	60 (2.36)	65 (2.56)	65 (2.56)	90 (3.54)	90 (3.54)	110 (4.33)	130 (5.12)	130 (5.12)
GG	41 (1.61)	50 (1.97)	77 (3.03)	84 (3.31)	91 (3.58)	106 (4.17)	106.5 (4.19)	108 (4.25)	123 (4.84)
1) Max velocità [RPM] 1) Max speed [RPM]	1750	1500	1250	1100	1000	850	750	700	650
Peso [kg] Weight [lb]	26 (57)	60 (132)	126 (277)	170 (374)	220 (484)	320 (704)	510 (1122)	600 (1320)	700 (1531)
Vol. cil. (nuovo) [lt] Cyl. Cap. (new) [in <sup>3</sup> ]	0.233 (14.25)	0.539 (32.90)	0.531 (32.40)	0.724 (44.17)	1.081 (65.97)	1.489 (90.83)	1.919 (117.11)	2.285 (139.43)	3.640 (222.18)
Vol. cil. (usurato) [lt] Cyl. Cap. (worn) [in <sup>3</sup> ]	0.455 (27.78)	0.970 (59.23)	1.035 (63.18)	1.412 (86.13)	2.119 (129.30)	2.923 (178.35)	3.769 (229.97)	4.487 (273.78)	7.801 (476.09)
Inerzia Corpo [Kgm <sup>2</sup> ] Inertia Body [lb-ft <sup>2</sup> ]	0,25 (5.93)	0,87 (20.65)	2,34 (55.53)	4,65 (110.34)	7,17 (170.14)	14,71 (349.07)	25,46 (604.17)	38,56 (915.03)	59,33 (1407.9)
Momento freno [Nm] Brake torque [lbin]	1800 (15,930)	3700 (32,708)	6800 (60,110)	11000 (97,240)	14000 (123,760)	20000 (176,800)	29000 (256,650)	38500 (340,350)	52000 (460,200)
Mom. Friz. (5,5bar) [Nm] Clutch torque (80Psi) [lbin]	1500 (13,270)	3100 (27,430)	5750 (50,880)	9000 (79,650)	12300 (108,850)	17350 (153,540)	24700 (218,590)	32350 (286,290)	45400 (401,790)

1) Non per operazioni in colpo singolo (consultare ns ufficio tecnico)

1) Not for single stroke operations (consult our engineering)

(\*) dimensioni delle piastrelle a pagina 16

(\*) keep plate's dimensions at page 16

dimensioni - dimensions in mm (inches)

**COPIE FRENO E FRIZIONE IN FUNZIONE  
DELLA PRESSIONE DI COMANDO E DEL NUMERO DI MOLLE  
CLUTCH AND BRAKE TORQUES  
DUE TO THE OPERATING PRESSURE AND THE SPRINGS NUMBER**

**SERIE  
SERIES AC e DC**

Grandezza Size	n° molle springs #	coppia freno [Nm] brake torque [lbin]	pressione apertura freno [bar (psi)] opening pressure [bar (psi)]	coppia frizione [Nm] alle pressioni [bar] clutch torque [lbin] at pressures [bar]					inerzia [kgm <sup>2</sup> ] inertia [lbf <sup>2</sup> ]
				6 bar	5.5 bar	5 bar	4.5 bar	4 bar	
AC 0250	12	1800 (15,930)	2,9 (42)	3680 (32,560)	3000 (26,550)	2320 (20,530)	1640 (14,510)	960 (8,490)	0.32 (7.59)
	10	1500 (13,270)	2,4 (35)	4420 (39,110)	3740 (33,090)	3060 (27,080)	2380 (21,060)	1700 (15,040)	0.31 (7.36)
	8	1200 (10,620)	1,9 (28)	5160 (45,660)	4480 (39,640)	3800 (33,630)	3120 (27,610)	2440 (21,590)	0.31 (7.36)
	6	900 (7,960)	1,5 (22)	5900 (52,210)	5220 (46,190)	4540 (40,170)	3860 (34,160)	3180 (28,140)	0.30 (7.12)
AC 0470	16	3700 (32,700)	3,0 (44)	7580 (67,080)	6200 (54,870)	4840 (42,830)	3500 (30,970)	2140 (18,930)	1.10 (26.10)
	14	3250 (28,730)	2,6 (38)	8700 (76,990)	7300 (64,600)	6000 (53,100)	4600 (40,710)	3220 (28,490)	1.09 (25.87)
	12	2800 (24,750)	2,2 (32)	9800 (86,730)	8400 (74,340)	7100 (62,830)	5700 (50,440)	4400 (38,940)	1.07 (25.39)
	10	2350 (20,770)	1,9 (28)	10900 (96,460)	9500 (84,070)	8200 (72,570)	6800 (60,180)	5400 (47,790)	1.06 (25.15)
	8	1850 (16,350)	1,5 (22)	12000 (106,200)	10600 (93,810)	9240 (81,770)	7900 (69,910)	6500 (57,520)	1.04 (24.68)
	6	1400 (12,370)	1,1 (16)	13100 (115,930)	11700 (103,540)	10320 (91,330)	9000 (79,650)	7600 (67,260)	1.02 (24.22)
AC 0900	16	6800 (60,110)	3,0 (44)	14000 (123,900)	11500 (101,770)	9000 (79,650)	6500 (57,520)	4000 (35,400)	2.93 (69.53)
	14	5950 (52,590)	2,6 (38)	15900 (140,710)	13500 (119,470)	11000 (97,350)	8500 (75,220)	6000 (53,100)	2.88 (68.34)
	12	5100 (45,080)	2,3 (33)	17900 (158,410)	15400 (136,290)	13000 (115,050)	10500 (92,920)	8000 (70,800)	2.84 (67.39)
	10	4250 (37,570)	1,9 (28)	19900 (176,110)	17400 (153,990)	14900 (131,860)	12500 (110,620)	10000 (88,500)	2.79 (66.21)
	8	3400 (30,056)	1,5 (22)	21900 (193,810)	19400 (171,690)	16900 (149,560)	14400 (127,440)	12000 (106,200)	2.75 (65.26)
	6	2550 (22,542)	1,1 (16)	23800 (210,630)	21400 (189,390)	18900 (167,260)	16400 (145,140)	13900 (123,010)	2.70 (64.07)
AC 1400	15	11000 (97,240)	3,1 (45)	21900 (193,810)	18000 (159,300)	14100 (124,780)	10100 (89,380)	6200 (54,870)	5.98 (141.91)
	12	8800 (77,792)	2,5 (36)	27000 (238,950)	23000 (203,550)	19100 (169,030)	15200 (134,520)	11200 (99,120)	5.82 (138.11)
	9	6600 (58,340)	2,0 (29)	32000 (283,200)	28100 (248,680)	24200 (214,170)	20200 (178,770)	16300 (144,250)	5.66 (134.31)
	6	4400 (38,890)	1,2 (17)	37100 (328,330)	33100 (292,930)	29200 (258,420)	25300 (223,900)	21300 (188,500)	5.50 (130.52)
AC 1900	18	14000 (123,760)	3,0 (44)	29700 (262,840)	24600 (217,710)	19400 (171,690)	14300 (126,550)	9100 (80,530)	8.96 (212.62)
	15	11650 (103,100)	2,6 (38)	35000 (309,750)	29900 (264,610)	24800 (219,480)	19600 (173,460)	14500 (128,320)	8.74 (207.40)
	12	9300 (82,300)	2,1 (30)	40300 (356,650)	35200 (311,520)	30100 (266,380)	24900 (220,360)	19800 (175,230)	8.52 (202.18)
	9	7000 (61,950)	1,7 (25)	45600 (403,560)	40500 (358,420)	35400 (313,290)	30200 (267,270)	25100 (222,130)	8.29 (196.72)
	6	4650 (41,150)	1,3 (19)	51000 (451,350)	45800 (405,330)	40700 (360,190)	35500 (314,170)	30400 (269,040)	8.07 (191.50)
AC 2600	21	20000 (176,800)	3,0 (44)	42000 (371,700)	34700 (307,090)	27400 (242,490)	20100 (177,880)	12700 (112,390)	18.55 (440.19)
	18	17150 (151,600)	2,6 (38)	48600 (430,110)	41300 (365,500)	33900 (300,010)	26600 (235,410)	19300 (170,800)	18.17 (431.17)
	15	14300 (126,410)	2,2 (32)	55100 (487,630)	47800 (423,030)	40500 (358,420)	33100 (292,930)	25800 (228,330)	17.78 (421.92)
	12	11400 (100,770)	1,7 (25)	61700 (546,040)	54300 (480,550)	47000 (415,950)	37700 (333,640)	32400 (286,740)	17.39 (412.66)
	9	8600 (76,020)	1,3 (19)	68200 (603,570)	60900 (538,960)	53600 (474,360)	46200 (408,870)	38900 (344,260)	17.00 (403.41)
AC 3800	21	29000 (256,650)	3,0 (44)	60000 (531,000)	49400 (437,190)	38800 (343,380)	28200 (249,570)	17600 (155,760)	32.41 (769.09)
	18	24850 (219,920)	2,6 (38)	69600 (615,960)	59000 (522,150)	48400 (428,340)	37800 (334,530)	27200 (240,720)	31.79 (754.38)
	15	20700 (183,190)	2,2 (32)	79200 (700,920)	68600 (607,110)	58000 (513,300)	47400 (419,490)	36800 (325,680)	31.17 (739.66)
	12	16550 (146,460)	1,7 (25)	88700 (784,990)	78100 (691,180)	67600 (598,260)	57000 (504,450)	46400 (410,640)	30.54 (724.71)
	9	12400 (109,740)	1,3 (19)	98300 (869,950)	87700 (776,140)	77100 (682,330)	66500 (588,520)	56000 (495,600)	29.92 (710.00)
AC 5100	21	38500 (340,350)	3,0 (44)	78600 (695,610)	64700 (572,590)	50800 (449,580)	36800 (325,680)	22900 (202,660)	48.90 (1160.4)
	18	33000 (291,720)	2,6 (38)	91300 (808,000)	77400 (684,990)	63400 (561,090)	49500 (438,070)	35500 (314,170)	47.93 (1137.4)
	15	27500 (243,100)	2,2 (32)	104000 (920,400)	90000 (796,500)	76100 (673,480)	62100 (549,580)	48200 (426,570)	46.95 (1114.1)
	12	22000 (194,480)	1,7 (25)	116600 (1,031,910)	102700 (908,890)	88700 (784,990)	74800 (661,980)	60900 (538,960)	45.97 (1090.9)
	9	16500 (145,860)	1,3 (19)	129300 (1,144,300)	115300 (1,020,400)	101400 (897,390)	87400 (773,490)	73500 (650,470)	44.99 (1067.6)
AC 7600	18	52000 (460,200)	3,0 (44)	110000 (973,500)	90800 (803,580)	71700 (634,540)	52600 (465,510)	33500 (296,470)	74.11 (1758.6)
	15	43300 (383,200)	2,5 (36)	129800 (1,148,730)	110700 (979,690)	91600 (810,660)	72500 (641,620)	53400 (472,590)	72.15 (1712.1)
	12	34650 (306,650)	2,0 (29)	149700 (1,324,840)	130600 (1,155,810)	111500 (986,770)	92400 (817,740)	73300 (648,700)	70.19 (1665.6)
	9	26000 (230,100)	1,5 (22)	169600 (1,500,960)	150500 (1,331,920)	131400 (1,162,890)	112300 (993,850)	93200 (824,820)	68.23 (1619.1)

**GRUPPO FRIZIONE-FRENO A COMANDO PNEUMATICO**  
**AIR ACTUATED CLUTCH-BRAKE UNIT**

SERIE  
SERIES **AC-CC**

FRIZIONE BIDISCO E FRENO  
MONODISCO  
DUAL-DISC CLUTCH AND  
SINGLE DISC BRAKE

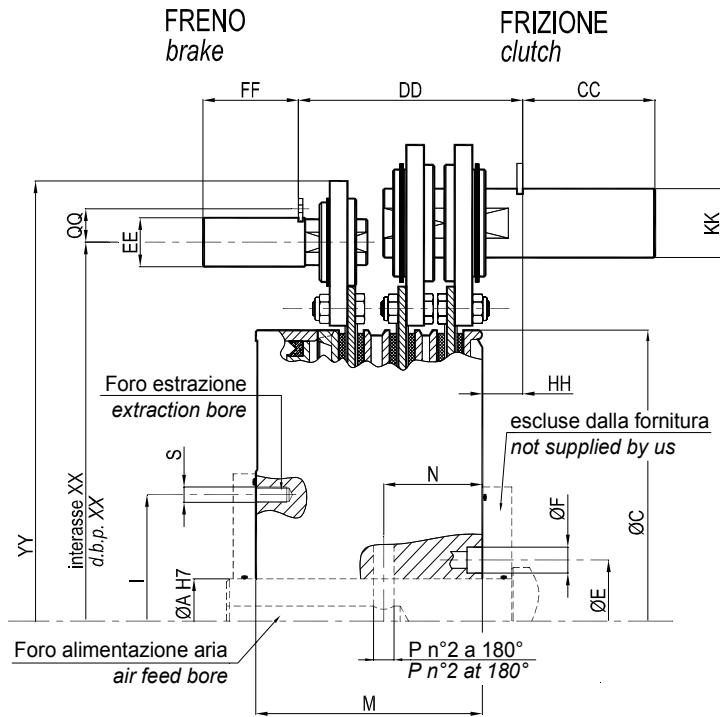

MODALITA' DI FISSAGGIO SULL'ALBERO  
MODALITY OF ON-SHAFT MOUNTING

1) Con **chiavette** a 90° rispetto ai fori di entrata aria  
2) Con **calettatori** (interpellare ns. uff tec.)

1) **keyways** at 90° against air inlet holes  
2) **with locking devices** (contact our engineering)

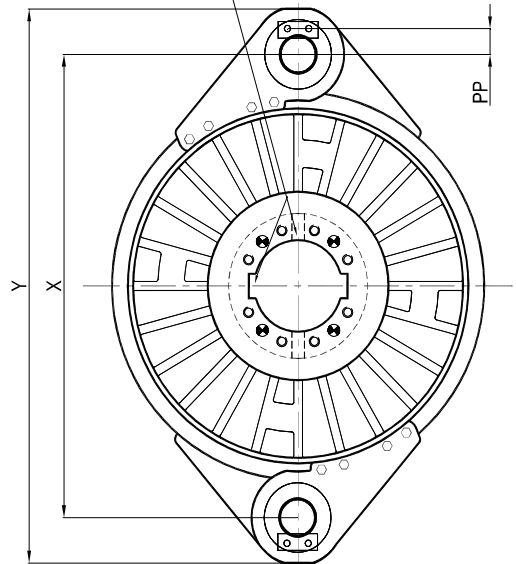

Grandezza Size	AC 0250	AC 0470	AC 0900	AC 1400	AC 1900	AC 2600	AC 3800	AC 5100	AC 7600
A max	80 (3.15)	95 (3.74)	125 (4.92)	140 (5.51)	160 (6.30)	180 (7.09)	200 (7.87)	220 (8.66)	240 (9.45)
A min	45 (1.77)	55 (2.17)	70 (2.76)	80 (3.15)	90 (3.54)	100 (3.94)	110 (4.33)	115 (4.53)	130 (5.12)
C	300 (11.81)	380 (14.96)	465 (18.31)	543 (21.38)	593 (23.35)	675 (26.57)	755 (29.72)	830 (32.68)	905 (35.63)
E	95 (3.74)	115 (4.53)	152 (5.98)	174 (6.85)	194 (7.64)	220 (8.66)	255 (10.04)	280 (11.02)	310 (12.20)
F	14.5 (0.57)	17 (0.67)	22 (0.87)	27.5 (1.08)	28 (1.10)	31 (1.22)	37 (1.46)	37 (1.46)	41 (1.61)
M	120.7 (4.75)	154.2 (6.07)	181.2 (7.13)	208.2 (8.20)	227.5 (8.95)	262.3 (10.32)	289 (11.38)	304 (11.97)	336.5 (13.25)
N CON CALETTATORE N WITH LOCKING DEVICE	54.5 (2.14)	69 (2.71)	83 (3.26)	94 (3.70)	105 (4.13)	120 (4.72)	138 (5.43)	146.5 (5.76)	162 (6.38)
N SENZA CALETTATORE N WITHOUT LOCKING DEVICE	54.5 (2.14)	69 (2.71)	87 (3.42)	99 (3.89)	111 (4.37)	125 (4.92)	138 (5.43)	146.5 (5.76)	162 (6.38)
I	127 (5)	165 (6.49)	205 (8.07)	230 (9.05)	245 (9.64)	275 (10.82)	305 (12.0)	315 (12.4)	360 (14.17)
P	11 (0.43)	14 (0.55)	17 (0.67)	20 (0.79)	21 (0.83)	25 (0.98)	28 (1.10)	30 (1.18)	32.5 (1.28)
S	M8	M10	M14	M18	M18	M20	M24	M24	M27
X	405 (15.94)	520 (20.47)	635 (25.00)	720 (28.35)	815 (32.09)	910 (35.83)	1020 (40.16)	1150 (45.27)	1220 (48.03)
Y	480 (18.90)	622 (24.49)	755 (29.72)	840 (33.07)	975 (38.38)	1070 (42.13)	1210 (47.63)	1364 (53.70)	1460 (57.48)
XX	390 (15.35)	495 (19.49)	610 (24.02)	695 (27.36)	770 (30.31)	880 (34.65)	970 (38.19)	1100 (43.31)	1178 (46.37)
YY	449 (17.68)	575 (22.64)	708 (27.87)	793 (31.22)	907 (35.7)	1030 (40.55)	1130 (44.49)	1264 (49.76)	1360 (53.54)
HH	13 (0.51)	27.5 (1.08)	30.5 (1.20)	21 (0.83)	50.5 (1.98)	26 (1.02)	38 (1.50)	40 (1.57)	40.5 (1.59)
KK	30 (1.18)	45 (1.77)	60 (2.36)	60 (2.36)	75 (2.95)	75 (2.95)	90 (3.54)	90 (3.54)	110 (4.33)
CC	45 (1.77)	90 (3.54)	119 (4.69)	119 (4.69)	150 (5.9)	130 (5.12)	180 (7.09)	180 (7.09)	180 (7.09)
DD	112.2 (4.42)	151 (5.94)	191.2 (7.52)	199.5 (7.85)	243.5 (9.58)	258 (10.16)	285 (11.22)	294 (11.57)	321.5 (12.65)
EE	22 (0.87)	32 (1.26)	45 (1.77)	45 (1.77)	60 (2.36)	60 (2.36)	65 (2.56)	75 (2.95)	75 (2.95)
FF	45 (1.77)	65 (2.56)	90 (3.54)	90 (3.54)	119 (4.69)	119 (4.69)	135 (5.31)	150 (5.91)	150 (5.91)
PP	P2* 20 (0.79)	P3* 31 (1.22)	P4* 39.5 (1.55)	P4* 39.5 (1.55)	P5* 52.5 (2.07)	P5* 52.5 (2.07)	P6* 60.5 (2.38)	P6* 60.5 (2.38)	P6* 70.5 (2.77)
QQ	P2* 15.5 (0.61)	P2* 21 (0.83)	P3* 29.5 (1.16)	P3* 29.5 (1.16)	P4* 39.5 (1.55)	P4* 39.5 (1.55)	P4* 42.5 (1.67)	P5* 52.5 (2.07)	P5* 52.5 (2.07)
1) Max velocità [RPM] 1) Max speed [RPM]	1750	1500	1250	1100	1000	850	750	700	650
Vol. cil. (nuovo) [lt] Cyl. Cap. (new) [in <sup>3</sup> ]	0.233 (14.25)	0.539 (32.90)	0.531 (32.40)	0.724 (44.17)	1.081 (65.97)	1.489 (90.83)	1.919 (117.11)	2.285 (139.43)	3.640 (222.18)
Vol. cil. (usurato) [lt] Cyl. Cap. (worm) [in <sup>3</sup> ]	0.455 (27.78)	0.970 (59.23)	1.035 (63.18)	1.412 (86.13)	2.119 (129.30)	2.923 (178.35)	3.769 (229.97)	4.487 (273.78)	7.801 (476.09)
Inerzia Corpo [Kgm <sup>2</sup> ] Inertia Body [lb-ft <sup>2</sup> ]	0.32 (7.59)	1.10 (26.10)	2.93 (69.53)	5.98 (141.91)	8.96 (212.62)	18.55 (440.19)	32.41 (769.09)	48.90 (1,160.4)	74.11 (1,758.6)
Momento freno [Nm] Brake torque [lbin]	1800 (15,930)	3700 (32,708)	6800 (60,110)	11000 (97,240)	14000 (123,760)	20000 (176,800)	29000 (256,650)	38500 (340,350)	52000 (460,200)
Mom. Friz. (5,5bar) [Nm] Clutch torque (80Psi) [lbin]	3000 (26,550)	6200 (54,800)	11500 (101,770)	18000 (159,300)	24600 (217,710)	34700 (307,090)	49400 (437,190)	64700 (572,590)	90800 (803,580)

1) Non per operazioni in colpo singolo (consultare ns ufficio tecnico)  
1) Not for single stroke operations (consult our engineering)

(\*) dimensioni delle piastrine a pagina 16  
(\* keep plate's dimensions at page 16)

dimensioni - dimensions in mm (inches)

**GRUPPO FRIZIONE-FRENO A COMANDO PNEUMATICO**  
**AIR ACTUATED CLUTCH-BRAKE UNIT**

SERIE  
 SERIES **AC-CS**

FRIZIONE BIDISCO E FRENO  
 MONODISCO  
 DUAL-DISC CLUTCH AND  
 SINGLE DISC BRAKE

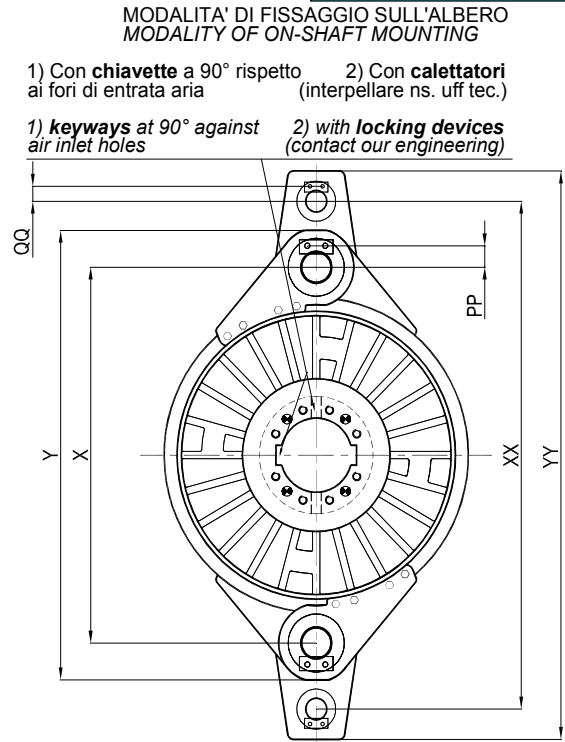
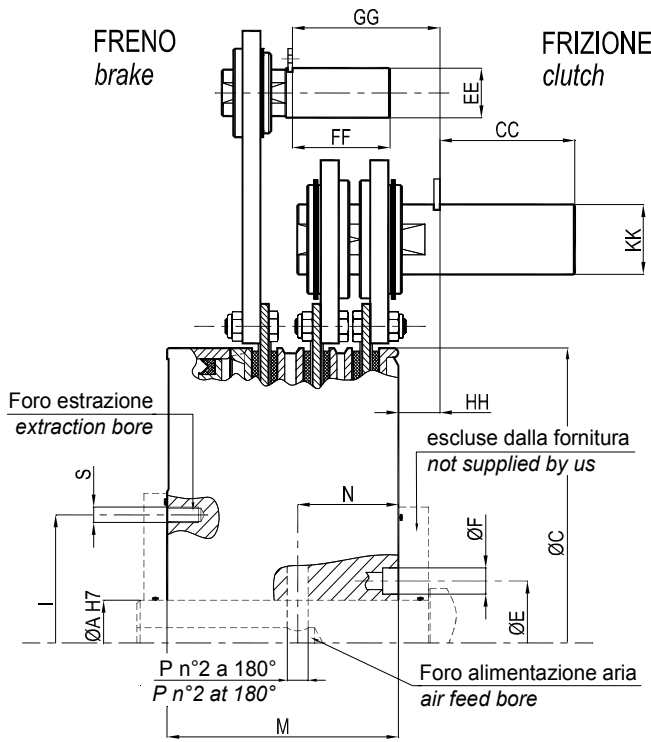

Grandezza Size	AC 0250	AC 0470	AC 0900	AC 1400	AC 1900	AC 2600	AC 3800	AC 5100	AC 7600
A max	80 (3.15)	95 (3.74)	125 (4.92)	140 (5.51)	160 (6.30)	180 (7.09)	200 (7.87)	220 (8.66)	240 (9.45)
A min	45 (1.77)	55 (2.17)	70 (2.76)	80 (3.15)	90 (3.54)	100 (3.94)	110 (4.33)	115 (4.53)	130 (5.12)
C	300 (11.81)	380 (14.96)	465 (18.31)	543 (21.38)	593 (23.35)	675 (26.57)	755 (29.72)	830 (32.68)	905 (35.63)
E	95 (3.74)	115 (4.53)	152 (5.98)	174 (6.85)	194 (7.64)	220 (8.66)	255 (10.04)	280 (11.02)	310 (12.20)
F	14.5 (0.57)	17 (0.67)	22 (0.87)	27.5 (1.08)	28 (1.10)	31 (1.22)	37 (1.46)	37 (1.46)	41 (1.61)
M	120.7 (4.75)	154.25 (6.07)	181.2 (7.13)	208.2 (8.20)	227.5 (8.95)	262.3 (10.32)	289 (11.38)	304 (11.97)	336.5 (13.25)
N CON CALETTATORE N WITH LOCKING DEVICE	54.5 (2.14)	69 (2.71)	83 (3.26)	94 (3.70)	105 (4.13)	120 (4.72)	138 (5.43)	146,5 (5.76)	162 (6.38)
N SENZA CALETTATORE N WITHOUT LOCKING DEVICE	54,5 (2.14)	69 (2.71)	87 (3.42)	99 (3.89)	111 (4.37)	125 (4.92)	138 (5.43)	146,5 (5.76)	162 (6.38)
I	127 (5)	165 (6.49)	205 (8.07)	230 (9.05)	245 (9.64)	275 (10.82)	305 (12.0)	315 (12,4)	360 (14.17)
P	11 (0.43)	14 (0.55)	17 (0.67)	20 (0.79)	21 (0.83)	25 (0.98)	28 (1.10)	30 (1.18)	32,5 (1.28)
S	M8	M10	M14	M18	M18	M20	M24	M24	M27
X	405 (15.94)	520 (20.47)	635 (25.00)	720 (28.35)	815 (32.09)	910 (35.82)	1040 (40.94)	1150 (45.27)	1220 (48.03)
Y	480 (18.90)	622 (24.49)	755 (29.72)	840 (33.07)	975 (38.38)	1070 (42.13)	1250 (49.21)	1364 (53.70)	1460 (57.48)
HH	13 (0.51)	27.7 (1.09)	30.5 (1.20)	21 (0.83)	50,5 (1.98)	33.5 (1.31)	38 (1.50)	40 (1.57)	40.5 (1.59)
KK	30 (1.18)	45 (1.77)	60 (2.36)	60 (2.36)	75 (2.95)	75 (2.95)	90 (3.54)	90 (3.54)	110 (4.33)
CC	45 (1.77)	90 (3.54)	119 (4.69)	119 (4.69)	150 (5.90)	130 (5.12)	180 (7.09)	180 (7.09)	180 (7.09)
PP	P2* 20 (0.79)	P3* 31 (1.22)	P4* 39,5 (1.55)	P4* 39,5 (1.55)	P5* 52,5 (2.07)	P5* 52,5 (2.07)	P6* 60,5 (2.38)	P6* 60,5 (2.38)	P6* 70,5 (2.77)
XX	515 (20.27)	675 (26.57)	810 (31.89)	900 (35.43)	1100 (43.3)	1155 (45.47)	1355 (53.34)	1500 (59.05)	1625 (63.98)
YY	558 (21.97)	740 (29.13)	880 (34.64)	970 (38.19)	1212 (47.71)	1267 (49.88)	1495 (58.86)	1660 (65.35)	1774 (69.84)
QQ	P1* 10,5 (0.41)	P2* 20 (0.79)	P2* 21,5 (0.84)	P2* 21,5 (0.84)	P3* 29,5 (1.16)	P3* 29,5 (1.16)	P4* 37,5 (1.47)	P4* 43 (1.67)	P4* 40 (1.57)
EE	16 (0.63)	30 (1.18)	32 (1.26)	32 (1.26)	45 (1.77)	45 (1.77)	55 (2.17)	65 (2.56)	65 (2.56)
FF	28 (1.10)	60 (2.36)	65 (2.56)	65 (2.56)	90 (3.54)	90 (3.54)	110 (4.33)	130 (5.12)	130 (5.12)
GG	73 (2.87)	97 (3.82)	122 (4.80)	130 (5.12)	144 (5.66)	165.5 (6.51)	179 (7.05)	179 (7.05)	207.5 (8.17)
1) Max velocità [RPM] 1) Max speed [RPM]	1750	1500	1250	1100	1000	850	750	700	650
Vol. cil. (nuovo) [lt] Cyl. Cap. (new) [in <sup>3</sup> ]	0.233 (14.25)	0.539 (32.90)	0.531 (32.40)	0.724 (44.17)	1.081 (65.97)	1.489 (90.83)	1.919 (117.11)	2.285 (139.43)	3.640 (222.18)
Vol. cil. (usurato) [lt] Cyl. Cap. (worm) [in <sup>3</sup> ]	0.455 (27.78)	0.970 (59.23)	1.035 (63.18)	1.412 (86.13)	2.119 (129.30)	2.923 (178.35)	3.769 (229.97)	4.487 (273.78)	7.801 (476.09)
Inerzia Corpo [Kgm <sup>2</sup> ] Inertia Body [lb-ft <sup>2</sup> ]	0.32 (7.59)	1.10 (26.10)	2.93 (69.53)	5.98 (141.91)	8.96 (212.62)	18.55 (440.19)	32.41 (769.09)	48.90 (1,160.4)	74.11 (1,758.6)
Momento freno [Nm] Brake torque [lbin]	1800 (15,930)	3700 (32,708)	6800 (60,110)	11000 (97,240)	14000 (123,760)	20000 (176,800)	29000 (256,650)	38500 (340,350)	52000 (460,200)
Mom. Friz. (5,5bar) [Nm] Clutch torque (80Psi) [lbin]	3000 (26,550)	6200 (54,800)	11500 (101,770)	18000 (159,300)	24600 (217,710)	34700 (307,090)	49400 (437,190)	64700 (572,590)	90800 (803,580)

1) Non per operazioni in colpo singolo (consultare ns ufficio tecnico)  
 1) Not for single stroke operations (consult our engineering)

(\*) dimensioni delle piastrine a pagina 16  
 (\*) keep plate's dimensions at page 16

dimensioni - dimensions in mm (inches)  
 13

# GRUPPO FRIZIONE-FRENO A COMANDO PNEUMATICO AIR ACTUATED CLUTCH-BRAKE UNIT

SERIE  
SERIES **DC-CC**

FRIZIONE BIDISCO E FRENO  
MONODISCO  
DUAL-DISC CLUTCH AND  
SINGLE DISC BRAKE

MODALITA' DI FISSAGGIO SULL'ALBERO  
MODALITY OF ON-SHAFT MOUNTING

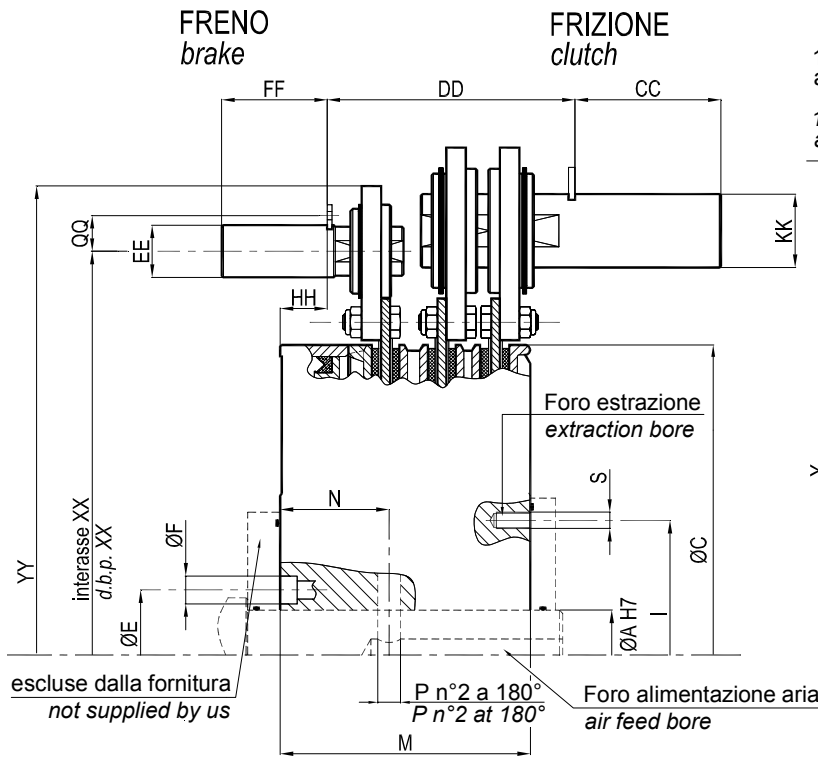

- 1) Con **chiavette** a 90° rispetto ai fori di entrata aria  
2) Con **calettatori** (interpellare ns. uff tec.)  
1) **keyways** at 90° against air inlet holes  
2) **with locking devices** (contact our engineering)

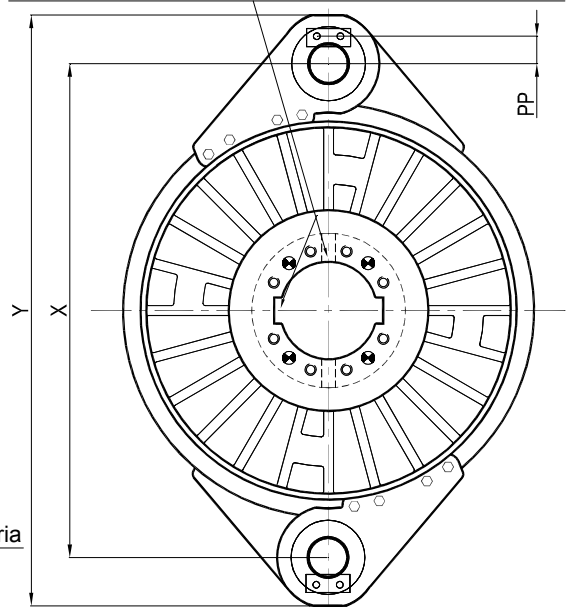

Grandezza Size	DC 0250	DC 0470	DC 0900	DC 1400	DC 1900	DC 2600	DC 3800	DC 5100	DC 7600
A max	80 (3.15)	95 (3.74)	125 (4.92)	140 (5.51)	160 (6.30)	180 (7.09)	200 (7.87)	220 (8.66)	240 (9.45)
A min	45 (1.77)	55 (2.17)	70 (2.76)	80 (3.15)	90 (3.54)	100 (3.94)	110 (4.33)	115 (4.53)	130 (5.12)
C	300 (11.81)	380 (14.96)	465 (18.31)	543 (21.38)	593 (23.35)	675 (26.57)	755 (29.72)	830 (32.68)	905 (35.63)
E	95 (3.74)	115 (4.53)	152 (5.98)	174 (6.85)	194 (7.64)	220 (8.66)	255 (10.04)	280 (11.02)	310 (12.20)
F	14.5 (0.57)	17 (0.67)	22 (0.87)	27.5 (1.08)	28 (1.10)	31 (1.22)	37 (1.46)	37 (1.46)	41 (1.61)
M	120.7 (4.75)	154.25 (6.07)	181.2 (7.13)	208.2 (8.20)	227 (8.93)	257 (10.11)	289 (11.38)	304 (11.97)	336.5 (13.25)
N	39 (1.53)	54.5 (2.15)	59.5 (2.34)	66.5 (2.62)	72.5 (2.85)	83.5 (3.29)	94 (3.70)	103 (4.06)	116 (4.57)
P	11 (0.43)	14 (0.55)	17 (0.67)	20 (0.79)	21 (0.83)	25 (0.98)	28 (1.10)	30 (1.18)	32.5 (1.28)
I	127 (5)	194.5 (7.65)	244 (9.6)	287 (11.29)	313 (12.32)	378 (14.88)	423 (16.65)	471 (18.54)	487 (19.17)
S	M8	M10	M14	M18	M18	M20	M24	M24	M27
X	405 (15.94)	520 (20.47)	635 (25.00)	720 (28.35)	815 (32.09)	910 (35.83)	1020 (40.16)	1100 (43.31)	1220 (48.03)
Y	480 (18.90)	622 (24.49)	755 (29.72)	840 (33.07)	975 (38.38)	1070 (42.13)	1210 (47.96)	1294 (50.94)	1460 (57.48)
XX	390 (15.35)	495 (19.49)	610 (24.02)	695 (27.36)	770 (30.31)	880 (34.65)	970 (38.19)	1150 (45.27)	1178 (46.37)
YY	449 (17.68)	575 (22.64)	708 (27.87)	793 (31.22)	907 (35.7)	1030 (40.55)	1130 (44.49)	1364 (53.70)	1360 (53.54)
HH	21.5 (0.85)	31 (1.22)	20.5 (0.81)	29.5 (1.16)	17.5 (0.68)	30 (1.18)	37 (1.46)	50 (1.97)	55.5 (2.18)
KK	30 (1.18)	45 (1.77)	60 (2.36)	60 (2.36)	75 (2.95)	75 (2.95)	90 (3.54)	90 (3.54)	110 (4.33)
CC	45 (1.77)	90 (3.54)	119 (4.69)	119 (4.69)	150 (5.90)	130 (5.12)	180 (7.09)	180 (7.09)	180 (7.09)
DD	112.2 (4.42)	151 (5.94)	191.2 (7.52)	199.5 (7.85)	243.5 (9.58)	258 (10.16)	290 (11.42)	294 (11.57)	321.5 (12.65)
EE	22 (0.87)	32 (1.26)	45 (1.77)	45 (1.77)	60 (2.36)	60 (2.36)	65 (2.56)	75 (2.95)	75 (2.95)
FF	45 (1.77)	65 (2.56)	90 (3.54)	90 (3.54)	119 (4.69)	119 (4.69)	130 (5.12)	150 (5.91)	150 (5.91)
PP	P2* 20 (0.79)	P3* 31 (1.22)	P4* 39.5 (1.55)	P4* 39.5 (1.55)	P5* 52.5 (2.07)	P5* 52.5 (2.07)	P6* 60.5 (2.38)	P6* 60.5 (2.38)	P6* 70.5 (2.77)
QQ	P2* 15.5 (0.61)	P2* 21 (0.83)	P3* 29.5 (1.16)	P3* 29.5 (1.16)	P4* 39.5 (1.55)	P4* 39.5 (1.55)	P4* 42.5 (1.67)	P5* 52.5 (2.07)	P5* 52.5 (2.07)
1) Max velocità [RPM] 1) Max speed [RPM]	1750	1500	1250	1100	1000	850	750	700	650
Vol. cil. (nuovo) [lt] Cyl. Cap. (new) [in <sup>3</sup> ]	0.233 (14.25)	0.539 (32.90)	0.531 (32.40)	0.724 (44.17)	1.081 (65.97)	1.489 (90.83)	1.919 (117.11)	2.285 (139.43)	3.640 (222.18)
Vol. cil. (usurato) [lt] Cyl. Cap. (worn) [in <sup>3</sup> ]	0.455 (27.78)	0.970 (59.23)	1.035 (63.18)	1.412 (86.13)	2.119 (129.30)	2.923 (178.35)	3.769 (229.97)	4.487 (273.78)	7.801 (476.09)
Inerzia Corpo [Kgm <sup>2</sup> ] Inertia Body [lb-ft <sup>2</sup> ]	0.32 (7.59)	1.10 (26.10)	2.93 (69.53)	5.98 (141.91)	8.96 (212.62)	18.55 (440.19)	32.41 (769.09)	48.90 (1,160.4)	74.11 (1,758.6)
Momento freno [Nm] Brake torque [lbin]	1800 (15,930)	3700 (32,708)	6800 (60,110)	11000 (97,240)	14000 (123,760)	20000 (176,800)	29000 (256,650)	38500 (340,350)	52000 (460,200)
Mom. Friz. (5,5bar) [Nm] Clutch torque (80Psi) [lbin]	3000 (26,550)	6200 (54,800)	11500 (101,770)	18000 (159,300)	24600 (217,710)	34700 (307,090)	49400 (437,190)	64700 (572,590)	90800 (803,580)

1) Non per operazioni in colpo singolo (consultare ns ufficio tecnico)  
1) Not for single stroke operations (consult our engineering)

(\*) dimensioni delle piastine a pagina 16  
(\* keep plate's dimensions at page 16)

dimensioni - dimensions in mm (inches)

# GRUPPO FRIZIONE-FRENO A COMANDO PNEUMATICO AIR ACTUATED CLUTCH-BRAKE UNIT

SERIE  
SERIES **DC-XB**

FRIZIONE BIDISCO E FRENO  
MONODISCO  
DUAL-DISC CLUTCH AND  
SINGLE DISC BRAKE

FRENO  
brake

FRIZIONE  
clutch

MODALITA' DI FISSAGGIO SULL'ALBERO  
MODALITY OF ON-SHAFT MOUNTING

1) Con **chiavette** a 90° rispetto ai fori di entrata aria  
2) Con **calettatori** (interpellare ns. uff tec.)

1) **keyways** at 90° against air inlet holes  
2) **with locking devices** (contact our engineering)

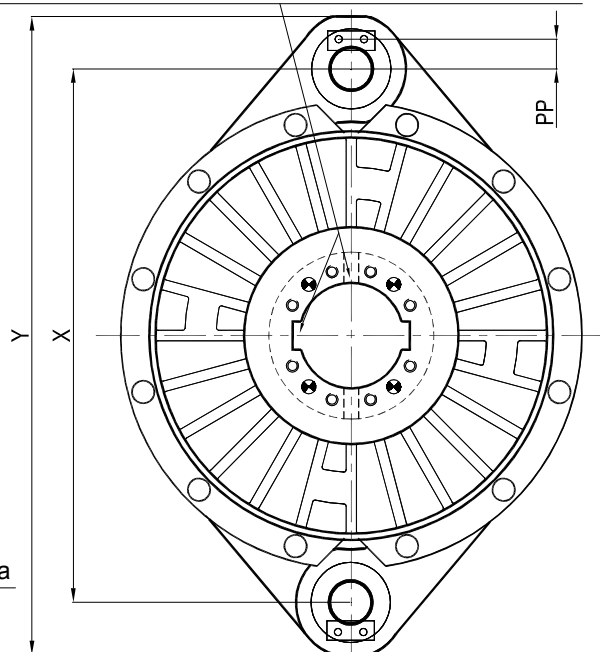
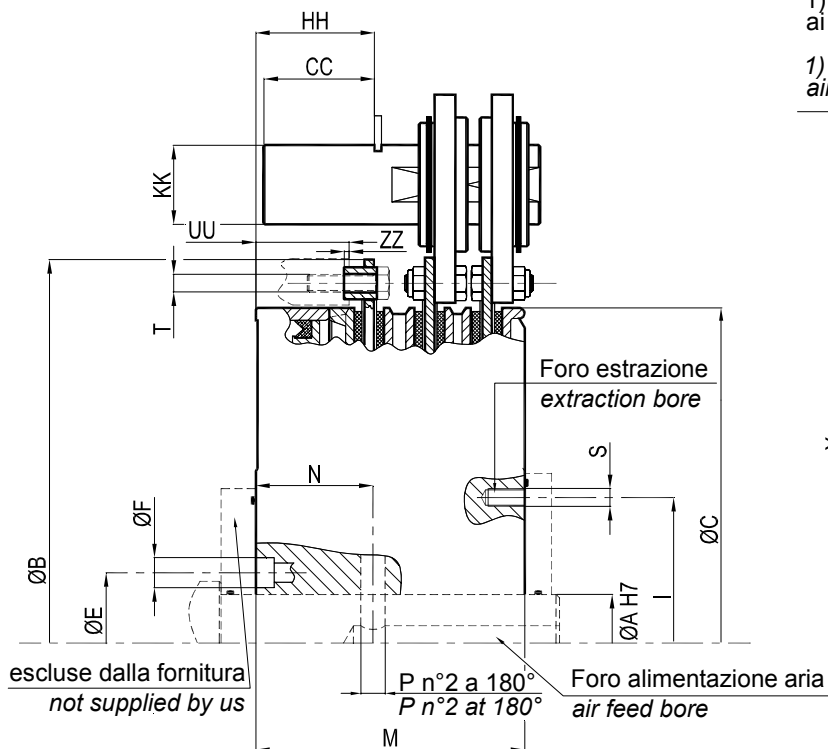

Grandezza Size	DC 0250	DC 0470	DC 0900	DC 1400	DC 1900	DC 2600	DC 3800	DC 5100	DC 7600
A max	80 (3.15)	95 (3.74)	125 (4.92)	140 (5.51)	160 (6.30)	180 (7.09)	200 (7.87)	220 (8.66)	240 (9.45)
A min	45 (1.77)	55 (2.17)	70 (2.76)	80 (3.15)	90 (3.54)	100 (3.94)	110 (4.33)	115 (4.53)	130 (5.12)
B	325 (12.80)	408 (16.06)	500 (19.69)	584 (22.99)	640 (25.20)	725 (28.54)	810 (31.89)	890 (35.04)	965 (37.99)
C	300 (11.81)	380 (14.96)	465 (18.31)	543 (21.38)	593 (23.35)	675 (26.57)	755 (29.72)	830 (32.68)	905 (35.63)
E	95 (3.74)	115 (4.53)	152 (5.98)	174 (6.85)	194 (7.64)	220 (8.66)	255 (10.04)	280 (11.02)	310 (12.20)
F	14.5 (0.57)	17 (0.67)	22 (0.87)	27.5 (1.08)	28 (1.10)	31 (1.22)	37 (1.46)	37 (1.46)	41 (1.61)
M	120.7 (4.75)	154.25 (6.07)	181.2 (7.13)	208.2 (8.20)	227 (8.93)	257 (10.31)	289 (11.38)	304 (11.97)	336.5 (13.25)
N	39 (1.53)	54.5 (2.15)	59.5 (2.34)	66.5 (2.62)	72.5 (2.85)	83.5 (3.29)	96 (3.78)	103 (4.06)	116 (4.57)
I	127 (5)	194.5 (7.65)	244 (9.6)	287 (11.29)	313 (12.32)	378 (14.88)	423 (16.65)	471 (18.54)	487 (19.17)
P	11 (0.43)	14 (0.55)	17 (0.67)	20 (0.79)	21 (0.83)	25 (0.98)	28 (1.10)	30 (1.18)	32.5 (1.28)
S	M8	M10	M14	M18	M18	M20	M24	M24	M27
X	405 (15.94)	520 (20.47)	634 (24.96)	720 (28.35)	815 (32.09)	910 (35.83)	1020 (40.16)	1150 (45.27)	1220 (48.03)
Y	480 (18.90)	622 (24.49)	754 (29.68)	840 (33.07)	975 (38.38)	1070 (42.13)	1210 (47.63)	1364 (53.70)	1460 (57.48)
T	M8	M10	M14	M14	M16	M20	M24	M24	M24
HH	54 (2.13)	68 (2.68)	72 (2.83)	93.5 (3.68)	71 (2.79)	125 (4.92)	123 (4.84)	140.5 (5.53)	156.5 (6.16)
KK	30 (1.18)	45 (1.77)	60 (2.36)	60 (2.36)	75 (2.95)	75 (2.95)	90 (3.54)	90 (3.54)	110 (4.33)
CC	45 (1.77)	90 (3.54)	119 (4.69)	119 (4.69)	150 (5.90)	130 (5.12)	180 (7.09)	180 (7.09)	180 (7.09)
PP	P2* 20 (0.79)	P3* 31 (1.22)	P4* 39.5 (1.55)	P4* 39.5 (1.55)	P5* 52.5 (2.07)	P5* 52.5 (2.07)	P6* 60.5 (2.38)	P6* 60.5 (2.38)	P6* 70.5 (2.77)
UU	36.5 (1.44)	55 (2.17)	61 (2.4)	70 (2.76)	76 (2.99)	88 (3.46)	93 (3.66)	103 (4.05)	110.5 (4.35)
ZZ	3 (0.12)	3 (0.12)	3 (0.12)	3 (0.12)	4 (0.16)	4 (0.16)	5 (0.20)	5 (0.20)	5 (0.20)
1) Max velocità [RPM] 1) Max speed [RPM]	1750	1500	1250	1100	1000	850	750	700	650
Vol. cil. (nuovo) [lt] Cyl. Cap. (new) [in <sup>3</sup> ]	0.233 (14.25)	0.539 (32.90)	0.531 (32.40)	0.724 (44.17)	1.081 (65.97)	1.489 (90.83)	1.919 (117.11)	2.285 (139.43)	3.640 (222.18)
Vol. cil. (usurato) [lt] Cyl. Cap. (worn) [in <sup>3</sup> ]	0.455 (27.78)	0.970 (59.23)	1.035 (63.18)	1.412 (86.13)	2.119 (129.30)	2.923 (178.35)	3.769 (229.97)	4.487 (273.78)	7.801 (476.09)
Inerzia Corpo [Kgm <sup>2</sup> ] Inertia Body [lb-ft <sup>2</sup> ]	0.32 (7.59)	1.10 (26.10)	2.93 (69.53)	5.98 (141.91)	8.96 (212.62)	18.55 (440.19)	32.41 (769.09)	48.90 (1,160.4)	74.11 (1,758.6)
Momento freno [Nm] Brake torque [lbin]	1800 (15,930)	3700 (32,708)	6800 (60,110)	11000 (97,240)	14000 (123,760)	20000 (176,800)	29000 (256,650)	38500 (340,350)	52000 (460,200)
Mom. Friz. (5,5bar) [Nm] Clutch torque (80Psi) [lbin]	3000 (26,550)	6200 (54,800)	11500 (101,770)	18000 (159,300)	24600 (217,710)	34700 (307,090)	49400 (437,190)	64700 (572,590)	90800 (803,580)

1) Non per operazioni in colpo singolo (consultare ns ufficio tecnico)

1) Not for single stroke operations (consult our engineering)

(\*) dimensioni delle piastrine a pagina 16

(\* keep plate's dimensions at page 16

dimensioni - dimensions in mm (inches)

## FLANGIA ADDUZIONE ARIA AIR INLET FLANGE

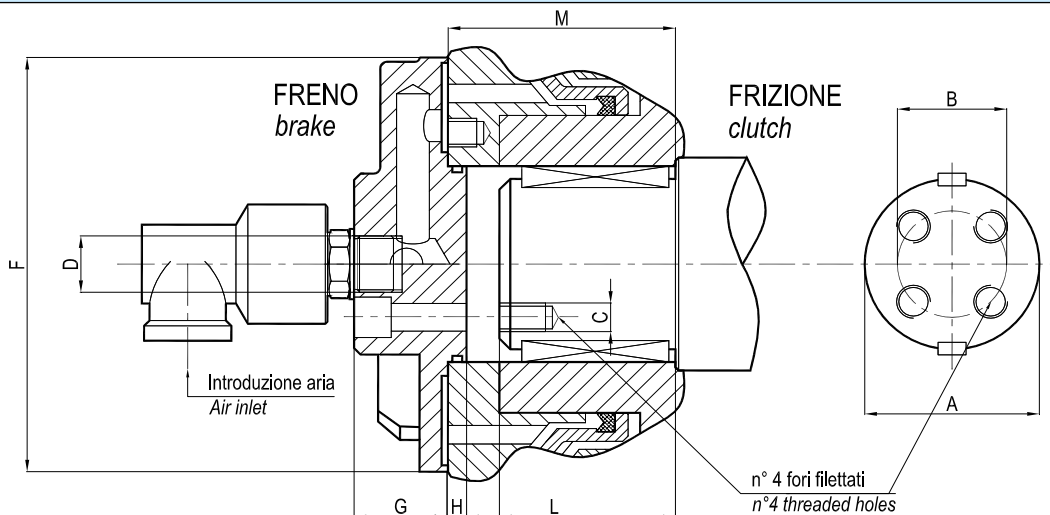

Grandezza Size	AS 0250	AS 0470	AS 0900	AS 1400	AS 1900	AS 2600	AS 3800	AS 5100	AS 7600
Amax	80 (3.15)	91 (3.58)	120 (4.72)	140 (5.51)	160 (6.30)	180 (7.09)	200 (7.87)	220 (8.66)	240 (9.45)
Amin	60 (2.36)	72 (2.83)	85 (3.35)	96 (3.78)	108 (4.25)	130 (5.12)	138 (5.43)	148 (5.83)	165 (6.50)
B	42 (1.65)	50 (1.97)	61 (2.40)	65 (2.56)	80 (3.15)	95 (3.74)	100 (3.94)	110 (4.33)	120 (4.72)
C	M10	M12	M14	M16	M16	M20	M20	M20	M24
D	1/2"	3/4"	1"	1"	1 1/4"	1 1/2"	1 1/2"	2"	2"
F	165 (6.50)	195 (7.68)	238 (9.37)	272 (10.71)	295 (11.61)	312 (12.28)	360 (14.17)	380 (14.96)	420 (16.54)
G	42 (1.65)	43 (1.69)	52 (2.05)	54 (2.13)	62 (2.44)	77 (3.03)	77 (3.03)	90 (3.54)	95 (3.74)
H	8.5 (0.33)	8.5 (0.33)	8.5 (0.33)	8.5 (0.33)	8.5 (0.33)	8.5 (0.33)	13 (0.51)	10 (0.39)	15 (0.59)
Lmax	80 (3.15)	105 (4.13)	128 (5.04)	146 (5.75)	160 (6.30)	185 (7.28)	200 (7.87)	220 (8.66)	235 (9.25)
M	94.5 (3.72)	122 (4.80)	145 (5.71)	165 (6.50)	180 (7.09)	205 (8.07)	228.5 (9.00)	240.5 (9.47)	263 (10.35)

dimensioni - dimensions in mm (inches)

## GIUNTO ROTANTE ADDUZIONE ARIA AIR INLET UNION

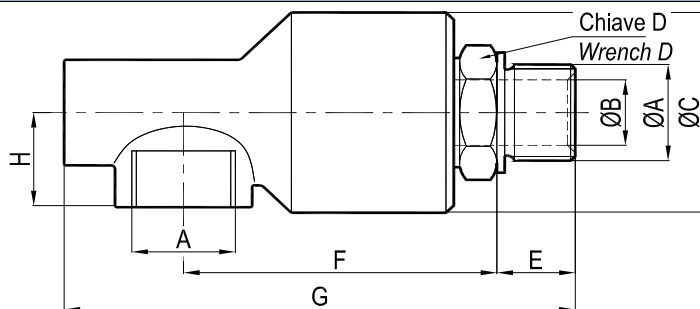

TIPO TYPE	A	B	C	D	E	F	G	H	Peso / Weight kg lbs	Velocità / Speed rpm
R 050	1/2"	4,5 (0,17)	35 (1,38)	27 (1,06)	18 (0,71)	80 (3,15)	111 (4,37)	30 (1,18)	0,75 (1,65)	1500
R 075	3/4"	17 (0,66)	56 (2,20)	32 (1,26)	20 (0,79)	86 (3,39)	122 (4,80)	36 (1,42)	0,96 (2,12)	1000
R 100	1"	22 (0,86)	65 (2,56)	41 (1,61)	23,5 (0,93)	98 (3,86)	138 (5,43)	40 (1,57)	1,4 (3,09)	700
U 125	1 1/4"	32 (1,26)	87 (3,43)	50 (1,97)	28 (1,10)	113 (4,45)	187 (7,36)	50 (1,97)	3,2 (7,06)	1500
U 150	1 1/2"	38 (1,49)	94 (3,70)	55 (2,17)	31 (1,22)	117 (4,61)	197 (7,76)	55 (2,17)	3,9 (8,60)	1000
U 200	2"	48 (1,89)	108 (4,25)	65 (2,56)	35 (1,38)	131 (5,16)	224 (8,82)	70 (2,76)	5,3 (11,69)	800

dimensioni - dimensions in mm (inches)

## PIASTRINE - KEEP PLATES

Piastrina --> Keep plate -->	P1	P2	P3	P4	P5	P6
A	20 (0,78)	25 (0,98)	35 (1,37)	45 (1,77)	60 (2,36)	60 (2,36)
B	35 (1,37)	42 (1,65)	55 (2,16)	65 (2,55)	85 (3,34)	90 (3,54)
C	5 (0,19)	7,5 (0,29)	10 (0,39)	15 (0,59)	20 (0,78)	20 (0,78)
D	10 (0,39)	15 (0,59)	20 (0,78)	25 (0,98)	40 (1,57)	40 (1,57)
E	7,5 (0,29)	8,5 (0,33)	10 (0,39)	10 (0,39)	12,5 (0,49)	15 (0,59)
F	4,5 (0,17)	5,5 (0,21)	6,5 (0,25)	8,5 (0,33)	10,5 (0,41)	10,5 (0,41)
S	3 (0,12)	3 (0,12)	4 (0,15)	5 (0,19)	8 (0,31)	8 (0,31)

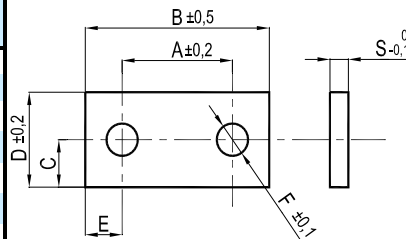



## ESEMPI DI MONTAGGIO MOUNTING STYLES

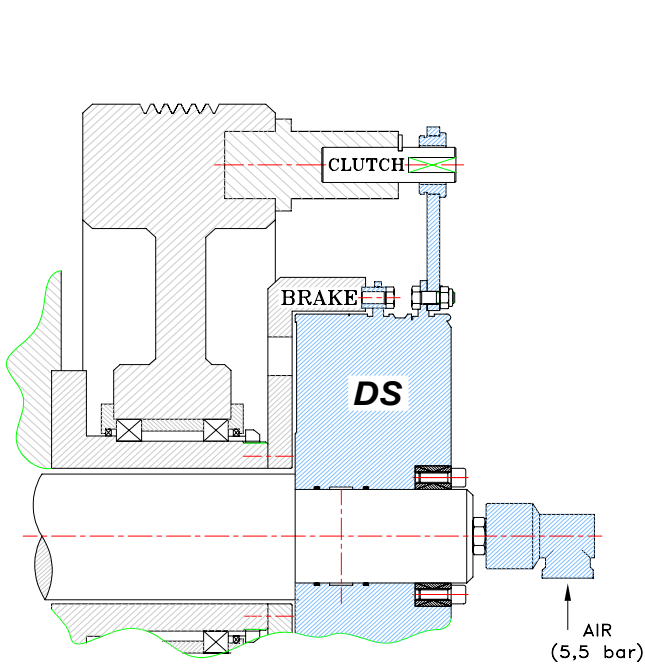

Volano su manicotto, gruppo f/f su albero e montaggio con calettatore  
*Flywheel on sleeve, c/b unit on shaft and mounting with locking device*

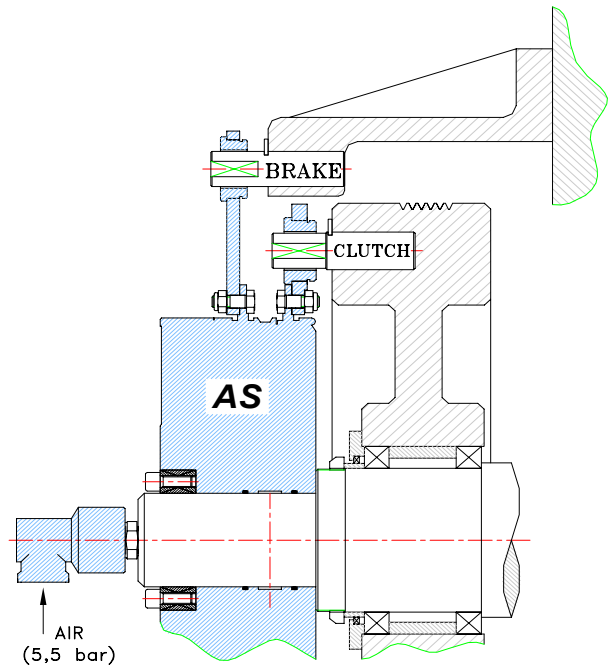

Freno collegato a sbalzo, frizione al volano e montaggio con calettatore  
*Brake overhanging, clutch connected to the flywheel and mounting with locking device*

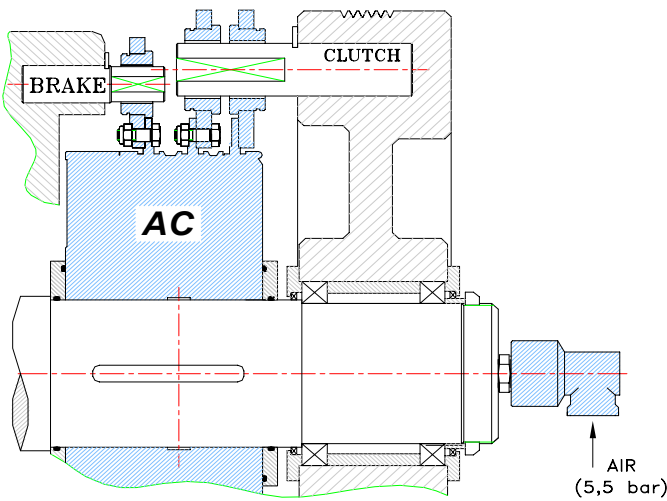

Frizione maggiorata collegata al volano esterno, freno alla cassa e montaggio con chiavette  
*Increased clutch connected to external flywheel, brake to frame and mounting with keyways*

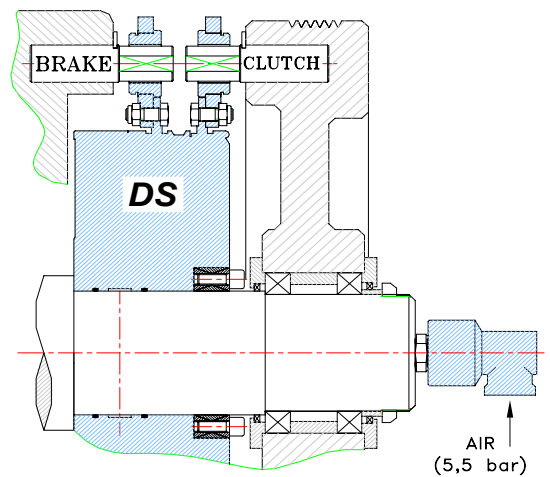

Frizione collegata al volano esterno, freno alla cassa e montaggio con calettatore  
*Clutch connected to external flywheel, brake to frame and mounting with locking device*

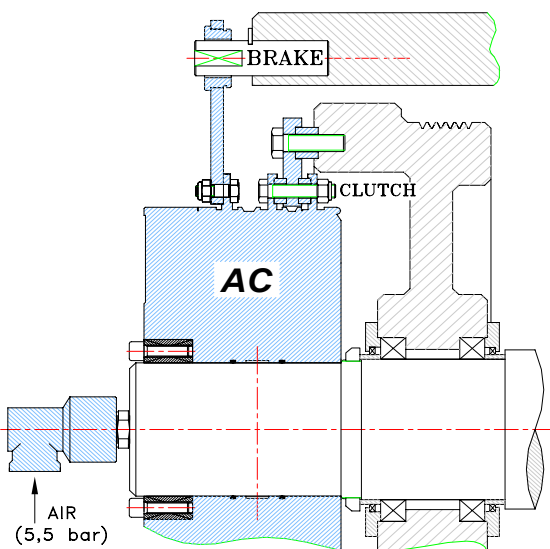

Frizione (con tasselli) maggiorata collegata al volano, freno collegato a sbalzo e montaggio con calettatore  
*Increased clutch with friction blocks connected to the flywheel, brake overhanging, and mounting with locking device*

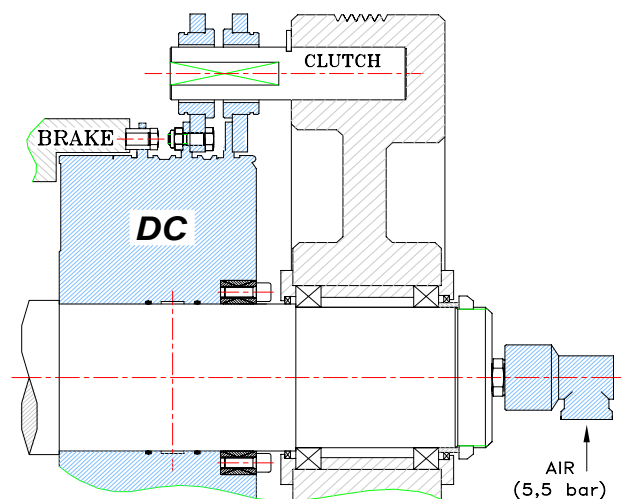

Frizione maggiorata collegata al volano esterno, freno alla cassa e montaggio con calettatore  
*Increased clutch connected to external flywheel, brake to frame and mounting with locking device*

## ALTRI PRODOTTI OTHER PRODUCTS

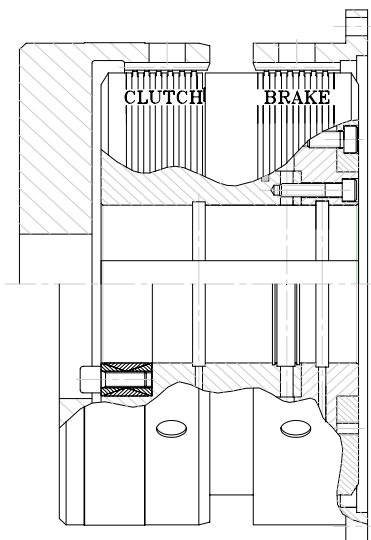

### SERIE WO - WO SERIES

Gruppi freno/frizione a comando idraulico in bagno d'olio  
*Hydraulically actuated clutch/brake units, wet running*

Coppie frizione - *Clutch torque values* : 1.000 ÷ 400.000 Nm  
Coppie freno - *Brake torque values* : 200 ÷ 215.000 Nm

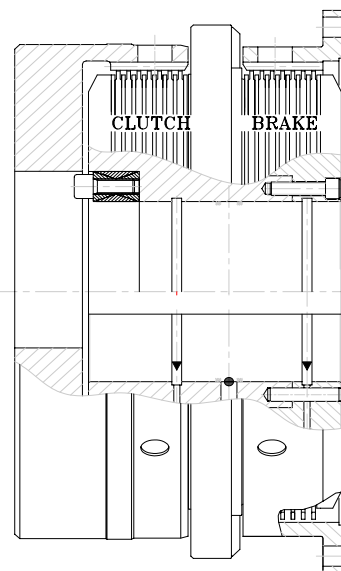

### SERIE WA - WA SERIES

Gruppi freno/frizione a comando pneumatico multidisco in bagno d'olio  
*Air actuated multi-plate clutch/brake units, wet running*

Coppie frizione - *Clutch torque values* : 3.000 ÷ 36.000 Nm  
Coppie freno - *Brake torque values* : 2000 ÷ 16.000 Nm

### OMPIPACK

Trasmissione premontata con gruppo freno/frizione a comando idraulico o pneumatico, per montaggio diretto su eccentrico o su ulteriore riduzione  
*Preassembled drive with pneumatic or hydraulic clutch/brake unit, for direct mounting on the crankshaft or on a further reduction*

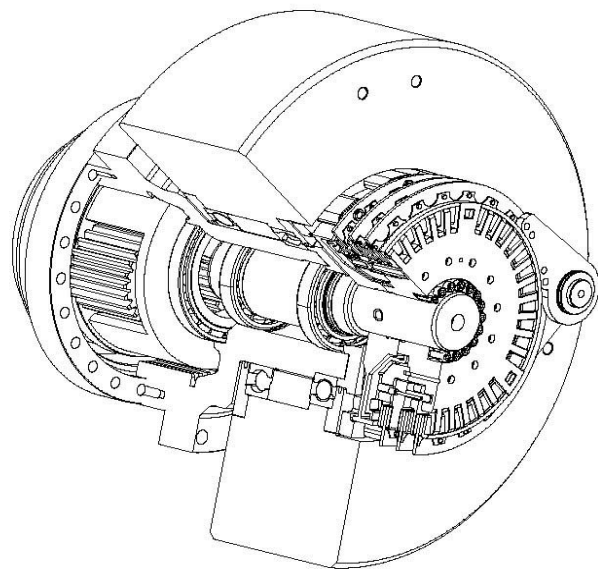
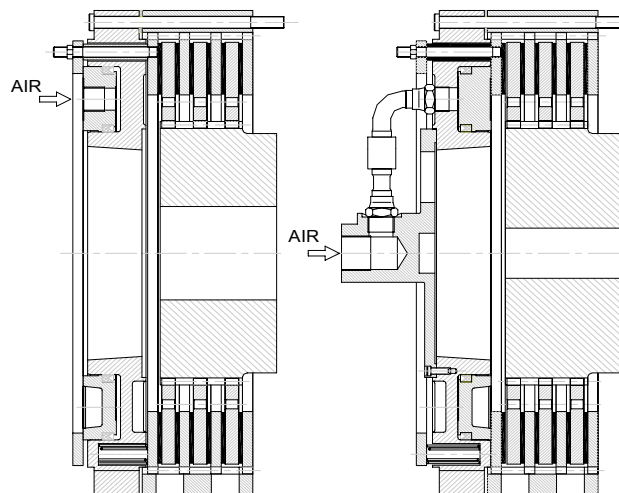

### SERIE SB - SB SERIES

Freno a pressione di molle (mono-, bi- o tridisco)  
*Spring loaded brake (single, double or three-plate)*

(Coppia fino a 3300 Nm)  
(Torque value: up to 3300 Nm)

### SERIE SK - SK SERIES

Frizione a comando pneumatico (mono-, bi- o tridisco)  
*Air actuated clutch (single, double or three-plate)*

(Coppia fino a 5000 Nm)  
(Torque value: up to 5000 Nm)